

T81

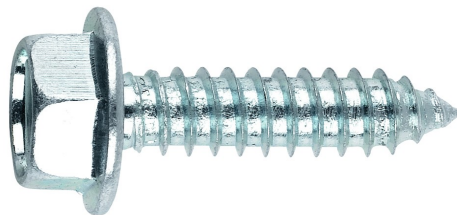

AUE



T82



TCP

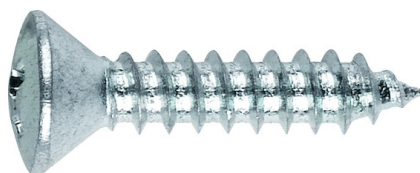

T83



TFI

CHARACTERISTICS

- ISO 1478 self-tapping thread.
- Require pre-drilling.
- Point Type C.
- Wide variety of head types, diameters and lengths for different applications: flexibility in installation.
- Zinc-plated or black zinc-plated coatings.
- Stainless steel versions.
- RAL colour scheme versions.
- Coloured caps available for hexagonal heads.

APPLICATIONS

- For fixing metallic elements, or plastic, wood, or other materials to metallic elements.
- Versions with galvanized steel-EPDM washer for sealed joints in façades and roofing.

BASE MATERIALS



MATERIALS

Characteristic	T81, T82, T83, AUE, TCP, TFI	TA281, TA282, TA282C, TCPA2
Material	Special steel for SAE J403 1022 thermal treatment	A2 Stainless Steel
Surface hardness	> 500 HV	---
Core hardness	240 - 450 HV	---
Depth hardness	ST 2.5 – 3.5: 0.05 – 0.18 mm. ST 3.9 – 5.5: 0.10 – 0.23 mm. ST 6.3: 0.15 – 0.28 mm.	---

1. RANGE

Code	Regulation	Head	Socket	∅ EPDM washer(1)	Material/Coating (2)	Material to be drilled
T81	DIN 7981	Domehead	Ph	---	Steel / Zinc-plated	Steel
T81-BLE	DIN 7981	Domehead	Ph	---	Steel / Zinc-plated + paint	Steel
TZN81	DIN 7981	Domehead	Ph	---	Steel / black zinc-plated	Steel
TA281	DIN 7981	Domehead	Ph	---	A2 Stainless (AISI 304)	Aluminium
T82	DIN 7982	Countersunk	Ph	---	Steel / Zinc-plated	Steel
T82-BLE	DIN 7982	Countersunk	Ph	---	Steel / Zinc-plated + paint	Steel
TZN82	DIN 7982	Countersunk	Ph	---	Steel / black zinc-plated	Steel
TA282	DIN 7982	Countersunk	Ph	---	A2 Stainless (AISI 304)	Aluminium
TA282C	DIN 7982	Countersunk	Square	---	A2 Stainless (AISI 304)	Aluminium
T83	DIN 7983	Oval head	Ph	---	Steel / Zinc-plated	Steel
AUE	DIN 6928	Hexagonal with flange	---	16, 18, 25	Steel / Zinc-plated	Steel
TCPZ	---	Extra-flat	Ph	---	Steel / Zinc-plated	Steel
TCPB	---	Extra-flat	Ph	---	Steel / Zinc-plated + paint	Steel
TCPN	---	Extra-flat	Ph	---	Steel / black zinc-plated	Steel
TCPA2	---	Extra-flat	Ph	---	A2 Stainless (AISI 304)	Aluminium
TFI	---	Extra-flat	Tx	---	Steel / Zinc-plated	Steel

(1) EPMD washer characteristics according to ARVUL Data Sheet.

(2) Coatings:

Zinc-plated $\geq 3 \mu\text{m}$ according to ISO 4042 A1J.

Black zinc-plated $\geq 3 \mu\text{m}$ according to ISO 4042 A1N.

2. INSTALLATION SPECIFICATIONS

2.1 PRE-DRILLING

For the correct installation of self-tapping screws, pre-drilling is to be according to the following table, depending on the base material and the thickness to be fixed (UNE 17020):

Thread	Steel or brass plate thickness [mm]				Aluminium plate thickness [mm]				
	0.4 - 0.6	0.6 - 1.5	1.5 - 2.5	2.5 - 4.0	0.4 - 0.6	0.6 - 1.0	1.0 - 1.5	1.5 - 2.5	2.5 - 4.0
ST 2.9	2.25	2.40	2.50	---	2.20	2.20	2.25	2.40	---
ST 3.5	2.70	2.80	2.90	3.00	2.70	2.70	2.80	2.80	---
ST 3.9	---	3.10	3.20	3.30	---	3.00	3.00	3.10	3.10
ST 4.2	---	3.30	3.40	3.50	---	3.20	3.20	3.30	3.30
ST 4.8	---	3.80	3.90	4.00	---	3.70	3.70	3.80	3.80
ST 5.5	---	4.40	4.50	4.60	---	4.30	4.30	4.40	4.40
ST 6.3	---	5.10	5.20	5.30	---	5.00	5.00	5.10	5.10

A pre-drill hole which is too large may cause the base material to strip the thread, or a loose fixing. A pre-drill hole which is too small may make threading the screw impossible, causing it to break or deforming the material to be fixed.

2.2 SCREW RESISTANCE CHARACTERISTICS

SIZE	TENSION [kN]	SHEAR [kN]
ST 2.9	2.62	1.31
ST 3.5	3.81	1.91
ST 3.9	4.64	2.32
ST 4.2	5.26	2.63
ST 4.8	7.11	3.56
ST 5.5	9.63	4.82
ST 6.3	13.36	6.68

1 kN ≈ 100 Kg

For tension loads, the inherent resistance of plates to be fixed must be taken into account, which is usually less than the resistance of the screw itself, as the screw will probably tear the plates.

2.3 RECOMMENDED TENSION LOAD IN STEEL PLATE

SIZE	RECOMMENDED LOAD					
	e [mm]	N [kN]	e [mm]	N [kN]	e [mm]	N [kN]
ST 3.5	0.8	0.47	1.5	0.93	2.0	1.64
ST 3.9	0.8	0.67	1.5	1.17	2.0	1.83
ST 4.2	2.0	1.8	2.5	1.48	3.0	3.37
ST 4.8	2.0	1.91	3.0	3.14	4.0	5.31
ST 5.5	2.0	1.96	3.5	3.34	5.0	3.42
ST 6.3	2.5	3.9	4.0	4.99	5.0	4.15

2.4 RECOMMENDED TENSION LOAD IN ALUMINIUM PLATE

SIZE	RECOMMENDED LOAD					
	e [mm]	N [kN]	e [mm]	N [kN]	e [mm]	N [kN]
ST 3.5	---	---	---	---	2.0	0.91
ST 4.2	2.0	0.84	---	---	3.0	2.21
ST 4.8	2.0	1.11	3.0	1.99	4.0	2.16
ST 5.5	2.0	1.02	4.0	3.59	5.0	3.63

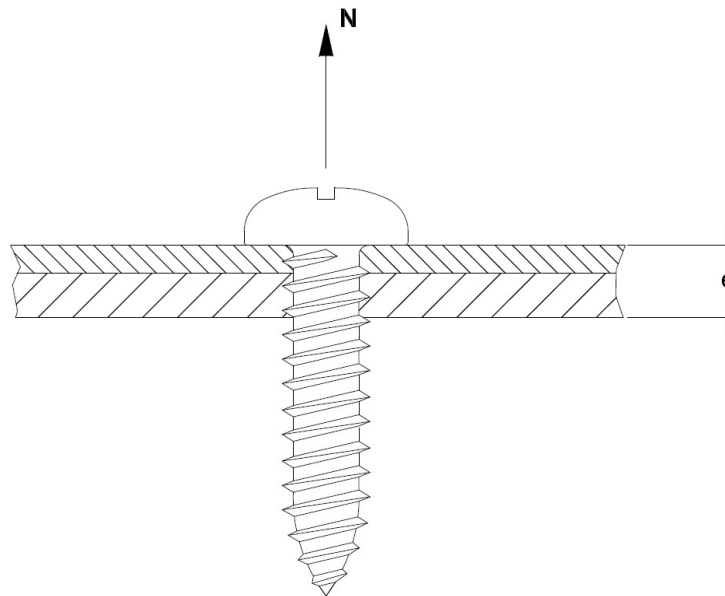

3. INSTALLATION DATA

3.1 DIN-7981 HP

Self-tapping screw – dome head – Ph socket

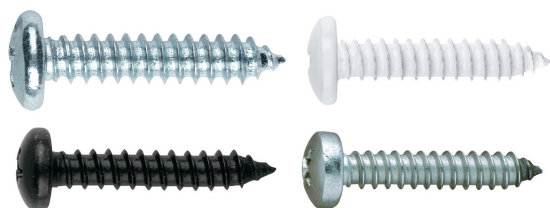

Properties



Steel



Available in stainless



Available in different colours

Coatings



Zinc-plated coating



White zinc-plated



Black zinc-plated



Ph

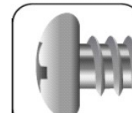

Dome head

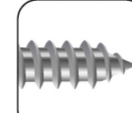

Self-tapping Point C

Code T81		ST 2.9	ST 3.5	ST 3.9	ST 4.2	ST 4.8	ST 5.5	ST 6.3
d_k : head diameter	[mm]	5.45	6.7	7.3	8.0	9.4	10.6	12.3
k: head thickness	[mm]	2.2	2.6	2.8	3.05	3.55	3.95	4.55
Ph bit no.		1	2	2	2	2	3	3
R: head radius	[mm]	4.4	5.4	5.8	6.2	7.2	8.2	9.5
D: exterior thread diameter	[mm]	2.90	3.53	3.90	4.22	4.80	5.46	6.25
d: interior thread diameter	[mm]	2.18	2.64	2.92	3.10	3.58	4.17	4.88
p: thread	[mm]	1.1	1.3	1.3	1.4	1.6	1.8	1.8
y: point length \leq	[mm]	2.6	3.2	3.5	3.7	4.3	5	6
l: lengths	[mm]	6.5 -- 25	6.5 -- 32	9.5 -- 50	9.5 -- 90	9.5 -- 120	13-- 120	16-- 120
l_G : maximum thread length	[mm]	--	--	--	--	90	90	90
Installation bit point code (Ph)		PUPHC01	PUPHC02	PUPHC02	PUPHC02	PUPHC02	PUPHC03	PUPHC03
		PUPHL01	PUPHL02	PUPHL02	PUPHL02	PUPHL02	PUPHL03	PUPHL03

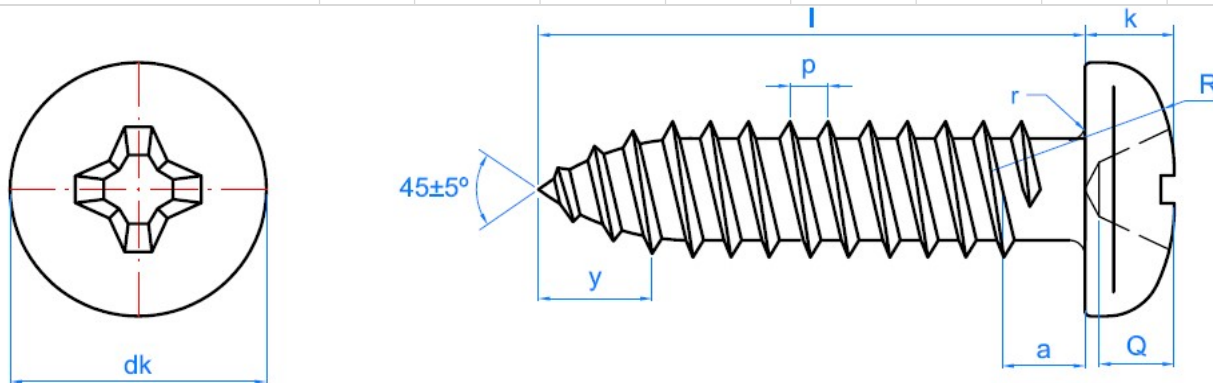

- Zinc-plated (code T81), A2 stainless steel (code TA281), white zinc-plated (T81__BLE) and black zinc-plated (TZN81) finishes.
- White zinc-plated measurements: 3.5 x 9.5, 4.2 x 13 y 4.2 x 25.
- Black zinc-plated measurements: 2.9 x 9.5, 3.5 x 13-25, 4.2 x 16-38 y 4.8 x 16-70.
- Stainless steel measurements: 2.9 x 9.5-25, 3.5 x 6.5-32, 3.9 x 9.5-25, 4.2 x 9.5-50, 4.8 x 16-70 y 5.5 x 13-70.
- General use in metal plate-metal plate fixings. For aluminium fixings, use stainless steel screw (code TA281).

3.2 DIN-7982 HP

Self-tapping screw – countersunk head – Ph socket



Propiedades



Steel



Available in stainless



Available in different colours

Coatings



Zinc-plated coating



White zinc-plated



Black zinc-plated

Properties



Ph

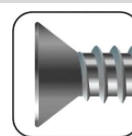

Countersunk head

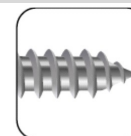

Self-tapping Point C

Code T82		ST 2.9	ST 3.5	ST 3.9	ST 4.2	ST 4.8	ST 5.5	ST 6.3
d_k : head diameter	[mm]	5.6	6.9	7.5	8.1	9.1	10.8	12.4
k: head thickness	[mm]	1.7	2.1	2.3	2.5	3	3.4	3.8
Ph bit no.		1	2	2	2	2	3	3
Head angle	$^\circ$	80	80	80	80	80	80	80
D: exterior thread diameter	[mm]	2.90	3.53	3.90	4.22	4.80	5.46	6.25
d: interior thread diameter	[mm]	2.18	2.64	2.92	3.10	3.58	4.17	4.88
p: thread	[mm]	1.1	1.3	1.3	1.4	1.6	1.8	1.8
y: point length \leq	[mm]	2.6	3.2	3.5	3.7	4.3	5	6
l_G : maximum thread length	[mm]	6.5 -- 25	9.5 -- 38	9.5 -- 50	13 -- 70	13 -- 70	13 -- 70	13 -- 70
Installation bit code (Ph)		PUPHC01	PUPHC02	PUPHC02	PUPHC02	PUPHC02	PUPHC03	PUPHC03
		PUPHL01	PUPHL02	PUPHL02	PUPHL02	PUPHL02	PUPHL03	PUPHL03

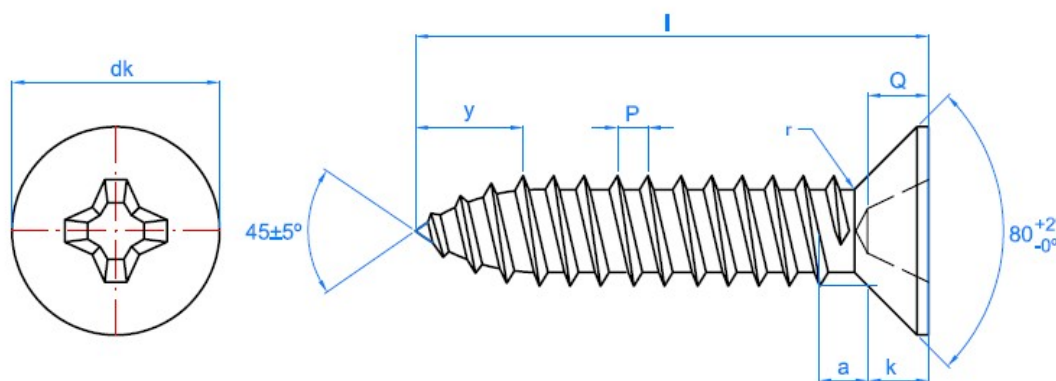

- Zinc-plated (code T82), A2 stainless steel (code TA282), white zinc-plated (T82__BLE) and black zinc-plated (TZN82) finishes.
- White zinc-plated measurements: 4.2 x 19.
- Black zinc-plated measurements: 4.2 x 19 y 4.2 x 25.
- Stainless steel measurements: 2.9 x 16, 3.5 x 9.5, 3.9 x 9.5-16, 4.2 x 16-50, 4.8 x 13-45 y 5.5 x 13-25.
- For metal-metal fixings where the screw is required to be level with the material to be fixed.

3.3 DIN-7982 HC

Self-tapping screw – countersunk head – Square socket

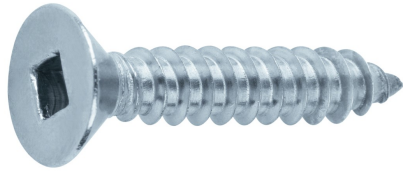

Properties



AISI 304Stainless steel

Properties



Square socket

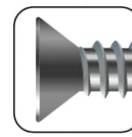

Countersunk head

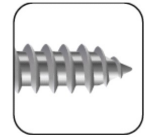

Self-tapping Point C

Code		ST 3.9	ST 4.2*	ST 4.8
d_k : head diameter	[mm]	7.5	8.5	9.1
k: head thickness	[mm]	2.3	2.5	3
Square bit no.		1	2	2
Head angle	$^\circ$	80	80	80
D: exterior thread diameter	[mm]	3.90	4.22	4.80
d: interior thread diameter	[mm]	2.92	3.10	3.58
p: thread	[mm]	1.3	1.4	1.6
y: point length \leq	[mm]	3.5	3.7	4.3
l_G : maximum thread length	[mm]	32	19 -- 50	19 -- 75
Installation bit code (Square)		PUCUC01 PUCUL01	PUCUC02 PUCUL02	PUCUC02 PUCUL02

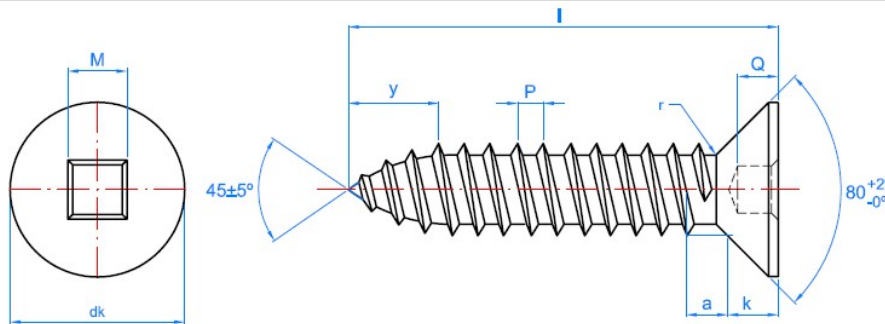

- For general use in fixings where the screw is required to be level with the material to be fixed.
- For fixings in Aluminium, use a stainless steel screw.

3.4 DIN-7983 HP

Self-tapping screw with 80° oval head

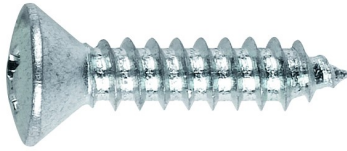

Properties

Steel

Zinc-plated coating

Properties

Ph

80° Oval head

Self-tapping Point C

Code		ST 2.9	ST 3.5	ST 3.9	ST 4.2	ST 4.8	ST 5.5	ST 6.3
d_k : head diameter	[mm]	5.5	6.8	7.5	8.1	9.5	10.8	12.4
k: head thickness	[mm]	1.7	2.1	2.3	2.5	3.	3.4	3.8
Ph bit no.		1	2	2	2	2	3	3
Head angle	°	80	80	80	80	80	80	80
D: exterior thread diameter	[mm]	2.90	3.53	3.90	4.22	4.80	5.46	6.25
d: interior thread diameter	[mm]	2.18	2.64	2.92	3.10	3.58	4.17	4.88
p: thread	[mm]	1.1	1.3	1.3	1.4	1.6	1.8	1.8
y: point length ≤	[mm]	2.6	3.2	3.5	3.7	4.3	5	6
l_G : maximum thread length	[mm]	9.5 -- 25	13 -- 38	9.5 -- 50	9.5 -- 70	13 -- 70	13 -- 70	13 -- 70
Installation bit code (Ph)		PUPHC01 PUPHL01	PUPHC02 PUPHL02	PUPHC02 PUPHL02	PUPHC02 PUPHL02	PUPHC02 PUPHL02	PUPHC03 PUPHL03	PUPHC03 PUPHL03

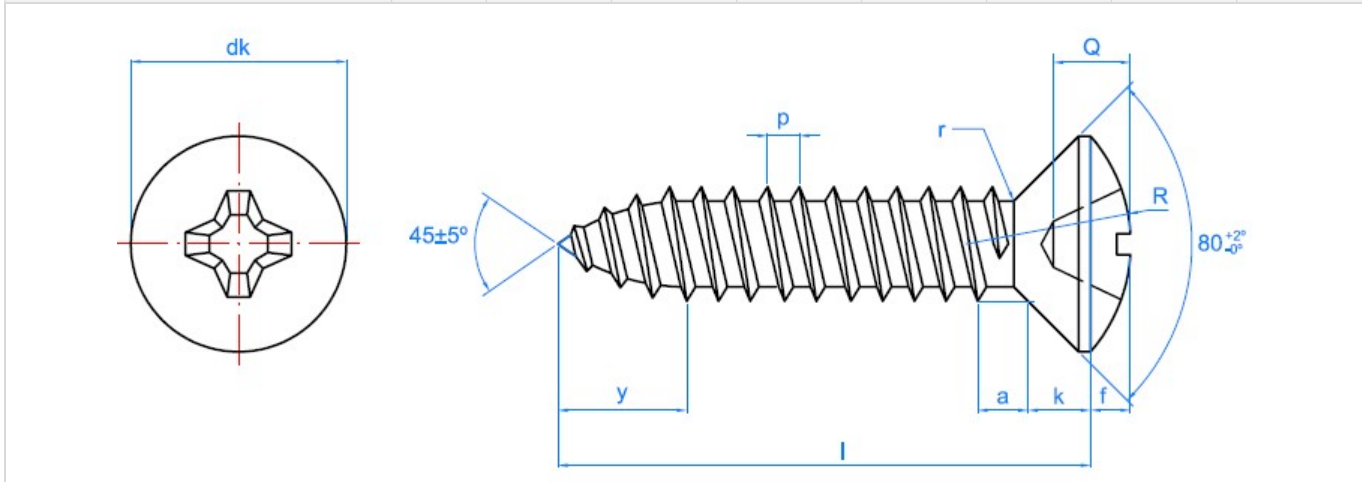

- For general use in metal-metal fixings where the screw is required to be level with the material to be fixed, but greater socket resistance is required (better torque transmission).

3.5 AUE

Self-tapping screw - hexagonal head with embossed washer

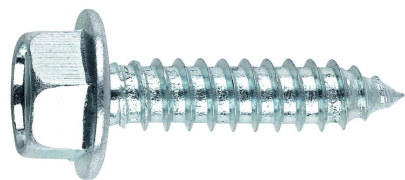

Properties



Steel



Zinc-plated coating



Available in different colours

Properties



Hexagonal socket

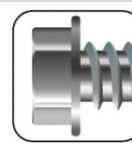

Hexagonal head with embossed washer

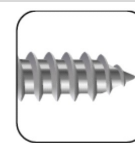

Self-tapping Point C

Code		ST 6.3
d _k : head washer diameter	[mm]	14
k: head thickness	[mm]	6
Spanner		10
D: exterior thread diameter	[mm]	6.25
d: interior thread diameter	[mm]	4.88
p: thread	[mm]	1.8
y: point length ≤	[mm]	19 -- 150
l _G : maximum thread length	[mm]	80
Installation socket code (hexagonal)		BOCA010

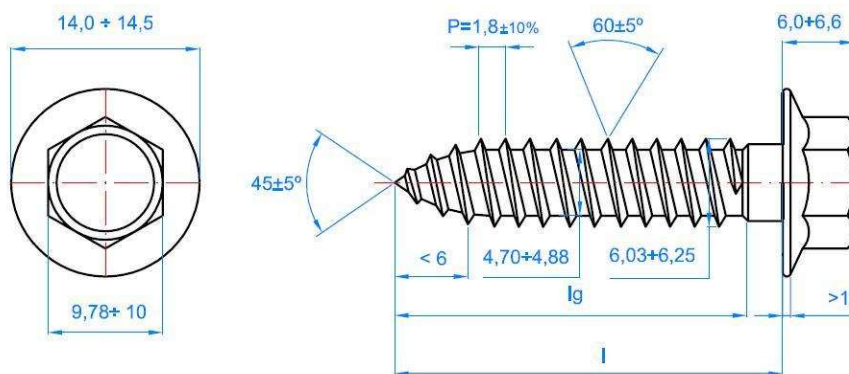
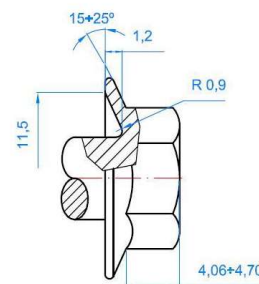

- Zinc-plated (code AUE) finish.
- Similar geometry to DIN 6928, with reinforced embossed washer:
 - better torque transmission.
 - better compressive stress distribution on material to be fixed.
 - more difficult to strip screw.
 - suitable for fixing soft materials, with large holes or when higher torque is required.
- For general use in metal-metal fixings where higher stress applications are required.

- Versions with $\varnothing 16$ mounted galvanized-EPDM washer, for sealed joints in façades and roofing (consult ARVUL Technical Data Sheet).



- Decorative plastic caps for AUE screws (code ATAP)

- | | |
|------------------|----------|
| ○ Pyrenean white | RAL 9002 |
| ○ Oyster white | RAL 9018 |
| ○ Sand | RAL 1001 |
| ○ Tile red | RAL 3011 |
| ○ Coral red | RAL 3003 |
| ○ Black | RAL 9005 |
| ○ Navarre green | RAL 6028 |



3.6 TCP

Self-tapping screw with extra-flat head



Properties



Steel



Available in stainless

Coatings



Zinc-plated coating



White zinc-plated



Black zinc-plated

Properties



Ph #2

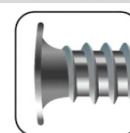

Extra-flat head

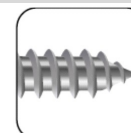

Self-tapping Point C

Code

ST 4.2

d_k : head diameter	[mm]	8.0
k: head thickness	[mm]	0.5
Ph bit no.		2
D: exterior thread diameter	[mm]	4.22
d: interior thread diameter	[mm]	3.10
p: thread	[mm]	1.4
y: point length \leq	[mm]	13 – 32
Countersunk head angle	$^\circ$	65
Installation bit code (Ph)		PUPHC02 PUPHL02

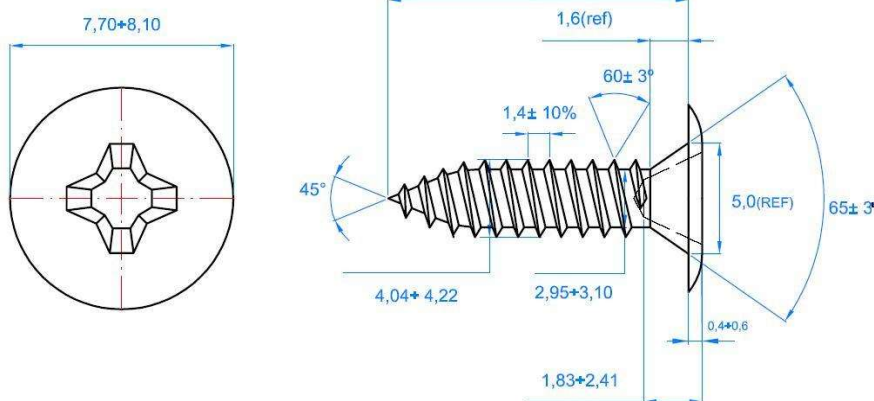

- Zinc-plated (code TCPZ), black zinc-plated (code TCPN), or completely white RAL 9010 painted (code TCPB) finishes.
- Version in A2 stainless steel, AISI 304 (code TCPA2).
- Bevelled head to prevent snagging on sliding parts.
- For joints on metal which require a very low head (sliding doors and windows, inlaid locks, etc.).
- May be used as a substitute for rivets in many applications, with the advantage of being removable.
- Reduced cone under head to improve finish on flat surfaces.
- For aluminium fixings, use stainless steel screw.

3.7 TFI

Special cylindrical extra-flat head screw, with double thread for Aluminium

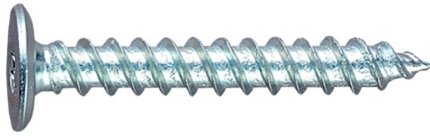

Properties		
Steel	Zinc-plated coating	
Properties		
Hexalobular Tx T20	Extra-flat head	Self-tapping Point C

Code		ST 4.8
d_k : head diameter	[mm]	10.50
k : head thickness	[mm]	1.76
Hexalobular bit (Tx) no.		20
Point length	[mm]	4
D: exterior thread diameter	[mm]	4.80
d: interior thread diameter	[mm]	3.05
p: thread	[mm]	1.6
y: point length \leq	[mm]	25 -- 90
Countersunk head angle	$^\circ$	59
Installation bit code (Tx)		PUTO20

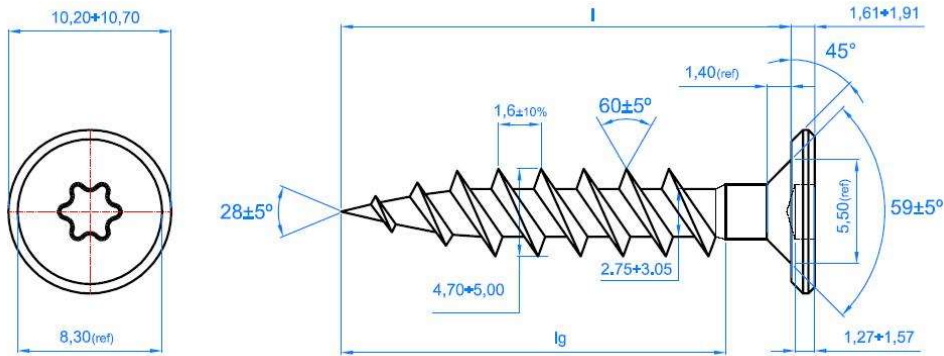

- Zinc-plated finish.
- Double thread.
- Fixing of aluminium frames on any base.
- Extra-flat head avoids countersinking and ensures greater surface support area on the frame.
- Versatile thread: for wood, nylon and metal.

4. COLOURS

All self-tapping screws may be supplied painted in the following options

4.1. Head only or head and EPDM washer

- White RAL 9010
- Pyrenean white RAL 9002
- Oyster white RAL 9018
- Bidasoa cream RAL 1000
- Sand RAL 1001
- Ivory RAL 1015
- Copper RAL 1007
- Tile red RAL 3011
- Coral red RAL 3003
- Burgundy RAL 3005
- Blue RAL 5009
- Lake blue RAL 5019
- Navarre green RAL 6028
- Light green RAL 6021
- Moss green RAL 6005
- Metallic grey RAL 9006
- Grey RAL 7035
- Black RAL 9005



Lengths: 13 – 90 mm. Diameters: 3.9 – 6.3 mm. Minimum quantity: 4000 units
Consult Sales Department for price and delivery time.

4.2. Completely painted

- White RAL 9010
- Black RAL 9005
- Burgundy RAL 3005
- Moss green RAL 6005
- Blue RAL 5009

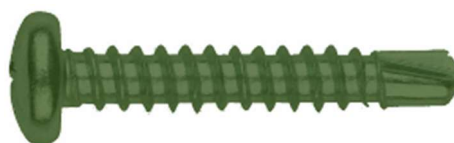

Lengths: 6.5 - 32 mm. Diameters: 2.9 – 5.5 mm. Minimum quantity: 15 kg
Consult Sales Department for price and delivery time.

5. COLOURED CUPS FOR HEAD SCREWS

5.1. Available coloured cups to decorate head screws:

- TPCRBL White
- TPCRNE Black



5.2. Available adherent coloured cups to decorate head screws

- TTPADBE Beige
- TTPADBL White
- TTPADCA Mahogany
- TTPADCE Cherry wood
- TTPADGR Grey
- TTPADHA Beech
- TTPADNE Black
- TTPADNO Walnut
- TTPADPI Pine
- TTPADRO Oak
- TTPADSA Sapele

