



THE



THT



THA



THP

## EIGENSCHAFTEN

- Funktion durch mechanische Überlagerung zwischen Gewinde und Beton.
- Für schwere Lasten. Hohe Feuerbeständigkeit.
- Zugelassen für 2 Einbautiefen bzw. bis zu 3 für Ø10.
- Geeignet für ungerissenen und gerissenen Beton.
- Erfüllt die Richtlinie VdS CEA 4001:2021-01(07) „Richtlinien für Sprinkleranlagen. Planung und Einbau“
- Besonders geeignet bei geringen Abständen zwischen Ankeren bzw. Rändern.
- Einsatz für statische oder quasistatische Lasten und seismische Beanspruchung C1 und C2.
- Einfache Montage.
- Installation mit der Bohrung des Anbauteils.
- Vorbohren erforderlich; das Gewinde wird beim Einbau des Ankers im Baustoff erstellt.
- Wiederverwendbar
- Ausbau möglich, ohne auf dem Untergrund des Grundmaterials Spuren zu hinterlassen.
- Verschiedene Längen und Größen, flexibler Einbau.
- VdS verfügbar von Ø8 bis Ø18
- Verfügbar in INDEXcal

## ANWENDUNGEN

- Konstruktive Befestigungen in gerissenem und ungerissenem Beton in Innenräumen
- Verglasungen, Fenster und Schaufenster
- Regale und Rohrgestelle
- Montage von Geländern und Handläufen in Innenbereichen
- Befestigungen von Holzbauten an Beton.

## ZULASSUNGEN



## BAUSTOFFE



## VERFÜGBARE GRÖßEN

Ø5 - Ø18

## BOHRLOCHBEDINGUNGEN



TROCKEN



NASS



MIT  
WASSER  
GEFÜLLT

## MAX. EMPFOHLENE ZUGTRAGFÄHIGKEIT IN UNGERISSENEM BETON [kg]

TH/TF

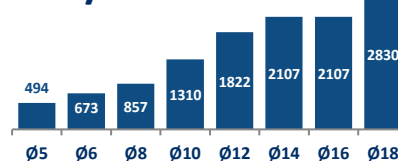

## ANWENDUNGSBEISPIEL



1. SORTIMENT						
POS.	ARTIKELNR.	GRÖßE	FOTO	BESCHREIBUNG	MATERIAL	BESCHICHTUNG
1	THE	Ø5 - Ø18		Sechskant-Flanschkopf mit Bund	Gestanzter Kohlenstoffstahl, ATLANTIS-Beschichtung	
2	THA	Ø5 - Ø10		Senkkopf	Gestanzter Kohlenstoffstahl, ATLANTIS-Beschichtung	
3	THT	Ø6		Flachrundkopf	Gestanzter Kohlenstoffstahl, ATLANTIS-Beschichtung	
4	THP	Ø5 - Ø8		Linsenkopf	Gestanzter Kohlenstoffstahl, ATLANTIS-Beschichtung	

2. EINBAUHINWEISE

2.1. EINBAUPLAN

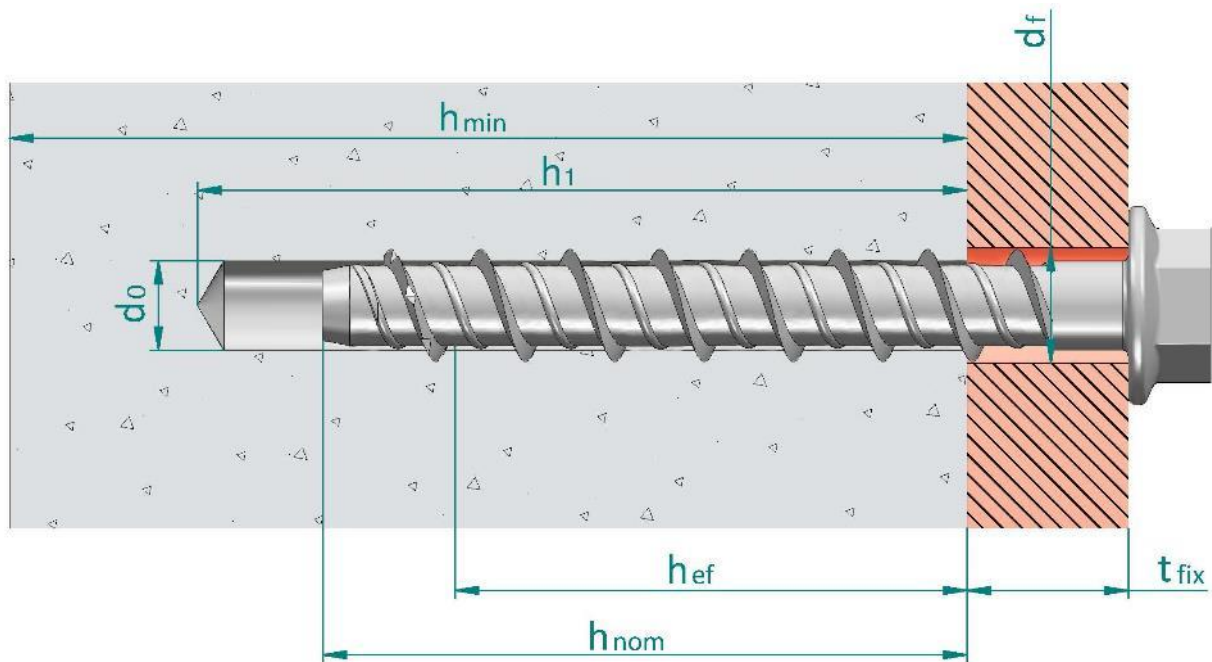

- $d_0$ : Nenn-Bohrungsdurchmesser
- $d_b$ : Bodenstärke der Spannbeton-Hohldecken
- $d_f$ : Durchmesser des Durchgangslochs im Anbauteil
- $h_{ef}$ : Effektive Verankerungstiefe
- $h_1$ : Bohrlochtiefe
- $h_{nom}$ : Verankerungstiefe im Beton
- $h_{min}$ : Minimale Betondicke
- $t_{fix}$ : Dicke des Anbauteils

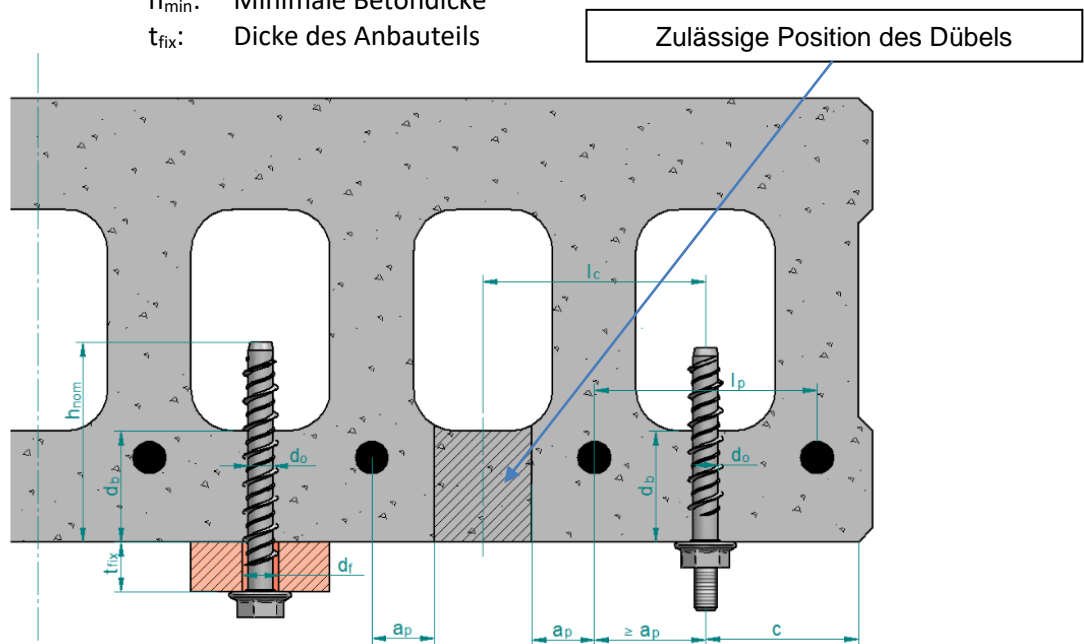

2.2. ERDBEBENZULASSUNG

Familie	Artikelnr.	Abmessung (Buchstabe)	Zulassung	C1	C2	Familie	Artikelnr.	Abmessung (Buchstabe)	Zulassung	C1	C2
[--]	[--]	[--]	ETA	[--]	[--]	[--]	[--]	[--]	ETA	[--]	[--]
THE	THE05040	Ø5 x 40 (A)	✓*	--	--	THE	THE16100	Ø16 x 100	✓	--	--
	THE05050	Ø5 x 50 (A)	✓*	--	--		THE16150	Ø16 x 150	✓	--	--
	THE05060	Ø5 x 60 (B)	✓*	--	--		THE18100	Ø18 x 100	✓	--	--
	THE05080	Ø5 x 80 (D)	✓*	--	--		THE18130	Ø18 x 130	✓	--	--
	THE05100	Ø5 x 100 (E)	✓*	--	--		THE18160	Ø18 x 160	✓	✓	✓
	THE06035	Ø6 x 35	✓	--	--		THE18180	Ø18 x 180	✓	✓	✓
	THE06040	Ø6 x 40	✓	--	--		THE18200	Ø18 x 200	✓	✓	✓
	THE06045	Ø6 x 45	✓	✓	--		THA05040	Ø5 x 40 (A)	✓*	--	--
	THE06050	Ø6 x 50	✓	✓	--		THA05060	Ø5 x 60 (B)	✓*	--	--
	THE06060	Ø6 x 60	✓	✓	--		THA05080	Ø5 x 80 (D)	✓*	--	--
	THE06070	Ø6 x 70	✓	✓	--		THA05100	Ø5 x 100 (E)	✓*	--	--
	THE06080	Ø6 x 80	✓	✓	--		THA06045	Ø6 x 45	✓	--	--
	THE06100	Ø6 x 100	✓	✓	--		THA06050	Ø6 x 50	✓	✓	--
	THE06120	Ø6 x 120	✓	✓	--		THA06060	Ø6 x 60	✓	✓	--
	THE08055	Ø8 x 55	✓	✓	✓		THA06080	Ø6 x 80	✓	✓	--
	THE08060	Ø8 x 60	✓	✓	✓		THA06100	Ø6 x 100	✓	✓	--
	THE08070	Ø8 x 70	✓	✓	✓		THA06120	Ø6 x 120	✓	✓	--
	THE08075	Ø8 x 75	✓	✓	✓		THA06140	Ø6 x 140	✓	✓	--
	THE08080	Ø8 x 80	✓	✓	✓	THA08060	Ø8 x 60	✓	✓	✓	
	THE08090	Ø8 x 90	✓	✓	✓	THA08080	Ø8 x 80	✓	✓	✓	
	THE08100	Ø8 x 100	✓	✓	✓	THA08100	Ø8 x 100	✓	✓	✓	
	THE08110	Ø8 x 110	✓	✓	✓	THA08120	Ø8 x 120	✓	✓	✓	
	THE08120	Ø8 x 120	✓	✓	✓	THA10100	Ø10 x 100	✓	✓	✓	
	THE08140	Ø8 x 140	✓	✓	✓	THA10120	Ø10 x 120	✓	✓	✓	
	THE10060	Ø10 x 60	✓	--	--	THE	THE				
	THE10070	Ø10 x 70	✓	--	--	THT	THE				
	THE10080	Ø10 x 80	✓	--	--		THE				
	THE10090	Ø10 x 90	✓	✓	✓		THE				
	THE10100	Ø10 x 100	✓	✓	✓	THP	THE				
	THE10120	Ø10 x 120	✓	✓	✓		THE				
	THE10140	Ø10 x 140	✓	✓	✓		THE				
	THE10160	Ø10 x 160	✓	✓	✓		THE				
	THE10180	Ø10 x 180	✓	✓	✓		THE				
	THE12080	Ø12 x 80	✓	--	--		THE				
	THE12090	Ø12 x 90	✓	--	--		THE				
	THE12100	Ø12 x 100	✓	✓	✓		THE				
	THE12110	Ø12 x 110	✓	✓	✓		THE				
	THE12130	Ø12 x 130	✓	✓	✓		THE				
	THE12150	Ø12 x 150	✓	✓	✓	THE					
	THE14080	Ø14 x 80	✓	--	--	THE					
	THE14100	Ø14 x 100	✓	--	--	THE					
	THE14110	Ø14 x 110	✓	✓	✓	THE					
THE14120	Ø14 x 120	✓	✓	✓	THE						
THE14130	Ø14 x 130	✓	✓	✓	THE						
THE14140	Ø14 x 140	✓	✓	✓	THE						
THE14160	Ø14 x 160	✓	✓	✓	THE						

## 3. EINBAUPARAMETER (BETON)

Allgemeine Einbaukennwerte										Standard-Einbautiefe ( $h_{ef, std}$ )								Reduzierte Einbautiefe ( $h_{ef, red}$ )										
Familie	Artikelnr.	Abmessung (Buchstabe)	Zulassung	Bohrungsdurchmesser	Bohrlochdurchmesser der zu befestigenden Dicke	Einbauschlüssel	Max. Einbaudrehmoment	Minimaler Achsabstand	Minimaler Abstand zum Rand	Minimale Betondicke	Bohrlochtiefe	Einbautiefe	Effektive Tiefe	Zu befestigende Dicke	Kritischer Achsabstand	Kritischer Abstand zum Rand (Ausbruch)	Kritischer Achsabstand (Spalten)	Kritischer Abstand zum Rand (Spalten)	Minimale Betondicke	Bohrlochtiefe	Einbautiefe	Effektive Tiefe	Zu befestigende Dicke	Kritischer Achsabstand	Kritischer Abstand zum Rand (Ausbruch)	Kritischer Achsabstand (Spalten)	Kritischer Abstand zum Rand (Spalten)	
[-]	[-]	[-]	ETA	$d_0$ [mm]	$d_f$ [mm]	SW/Tx [-]	$T_{inst}$ [Nm]	$S_{min}$ [mm]	$C_{min}$ [mm]	$h_{min}$ [mm]	$h_1$ [mm]	$h_{nom}$ [mm]	$h_{ef}$ [mm]	$t_{fix}$ [mm]	$S_{cr,N}$ [mm]	$C_{cr,N}$ [mm]	$S_{cr,sp}$ [mm]	$C_{cr,sp}$ [mm]	$h_{min}$ [mm]	$h_1$ [mm]	$h_{nom}$ [mm]	$h_{ef}$ [mm]	$t_{fix}$ [mm]	$S_{cr,N}$ [mm]	$C_{cr,N}$ [mm]	$S_{cr,sp}$ [mm]	$C_{cr,sp}$ [mm]	
THE	THE05040	Ø5 x 40(A)	✓*	5	6,5 - 8	SW 8	8	35	35	80	55	45	35,0	--	105	53	105	53	80	45	35	26,5	5	80	40	80	40	
	THE05050	Ø5 x 50(A)	✓*			15																						
	THE05060	Ø5 x 60(B)	✓*			25																						
	THE05080	Ø5 x 80(D)	✓*			35																						
	THE05100	Ø5 x 100(E)	✓*			55																						
	THE06035	Ø6 x 35	✓	6	7,5 - 9	SW 10	10	35	35	--	100	65	55	43,0	--	129	65	170	85	100	45	35	26,0	--	78	39	90	45
	THE06040	Ø6 x 40	✓			5																						
	THE06045	Ø6 x 45	✓			10																						
	THE06050	Ø6 x 50	✓			15																						
	THE06060	Ø6 x 60	✓			25																						
	THE06070	Ø6 x 70	✓			35																						
	THE06080	Ø6 x 80	✓			45																						
	THE06100	Ø6 x 100	✓			65																						
	THE06120	Ø6 x 120	✓			85																						
	THE08055	Ø8 x 55	✓			8				10,5 - 12					SW 13									20				
	THE08060	Ø8 x 60	✓	10																								
	THE08070	Ø8 x 70	✓	20																								
	THE08075	Ø8 x 75	✓	25																								
	THE08080	Ø8 x 80	✓	30																								
	THE08090	Ø8 x 90	✓	40																								
	THE08100	Ø8 x 100	✓	50																								
	THE08110	Ø8 x 110	✓	60																								
	THE08120	Ø8 x 120	✓	70																								
	THE08140	Ø8 x 140	✓	90																								

\*Ø5 Zulassung nur für Verankerungen in Beton und vorgefertigten Spannbeton-Hohldecken für redundante nichttragende Systeme

## Allgemeine Einbaukennwerte

## Standard-Einbautiefe ( $h_{ef, std}$ )

## Reduzierte Einbautiefe ( $h_{ef, red}$ )

Familie	Artikelnr.	Abmessung (Buchstabe)	Zulassung	Bohrungsdurchmesser	Bohrlochdurchmesser der zu befestigenden Dicke	Einbauschlüssel	Max. Einbaudrehmoment	Minimaler Achsabstand	Minimaler Abstand zum Rand	Standard-Einbautiefe ( $h_{ef, std}$ )								Reduzierte Einbautiefe ( $h_{ef, red}$ )																						
										Minimale Betondicke	Bohrlochtiefe	Einbautiefe	Effektive Tiefe	Zu befestigende Dicke	Kritischer Achsabstand	Kritischer Abstand zum Rand (Ausbruch)	Kritischer Achsabstand (Spalten)	Kritischer Abstand zum Rand (Spalten)	Minimale Betondicke	Bohrlochtiefe	Einbautiefe	Effektive Tiefe	Zu befestigende Dicke	Kritischer Achsabstand	Kritischer Abstand zum Rand (Ausbruch)	Kritischer Achsabstand (Spalten)	Kritischer Abstand zum Rand (Spalten)													
[--]	[--]	[--]	ETA	$d_0$	$d_f$	SW/Tx	$T_{inst}$	$S_{min}$	$C_{min}$	$h_{min}$	$h_1$	$h_{nom}$	$h_{ef}$	$t_{fix}$	$S_{cr,N}$	$C_{cr,N}$	$S_{cr,sp}$	$C_{cr,sp}$	$h_{min}$	$h_1$	$h_{nom}$	$h_{ef}$	$t_{fix}$	$S_{cr,N}$	$C_{cr,N}$	$S_{cr,sp}$	$C_{cr,sp}$													
				[mm]	[mm]	[--]	[Nm]	[mm]	[mm]	[mm]	[mm]	[mm]	[mm]	[mm]	[mm]	[mm]	[mm]	[mm]	[mm]	[mm]	[mm]	[mm]	[mm]	[mm]	[mm]	[mm]	[mm]	[mm]												
THE	THE10060	Ø10 x 60	✓	10	12,5 - 14	SW 15	30	50	40	--	--	--	--	--	--	--	--	--	100	65	55	41,5	5	125	63	140	70													
	THE10070	Ø10 x 70	✓			15																																		
	THE10080	Ø10 x 80	✓			25																																		
	THE10090	Ø10 x 90	✓			35																																		
	THE10100	Ø10 x 100	✓			5																																		
	THE10120	Ø10 x 120	✓			15																																		
	THE10140	Ø10 x 140	✓			35																																		
	THE10160	Ø10 x 160	✓			55																																		
	THE10180	Ø10 x 180	✓			75																																		
	THE12080	Ø12 x 80	✓	12	14,8 - 16	SW 18	50	75	45	--	--	--	--	--	--	--	--	--	120	90	75	58,0	5	174	87	190	95													
	THE12090	Ø12 x 90	✓			15																																		
	THE12100	Ø12 x 100	✓			25																																		
	THE12110	Ø12 x 110	✓			35																																		
	THE12130	Ø12 x 130	✓			5																																		
	THE12150	Ø12 x 150	✓			25																																		
	THE14080	Ø14 x 80	✓			14				16,9 - 18	SW 21	70	80	50	--	--	--	--					--					--	--	--	--	120	90	75	58,0	5	174	87	190	95
	THE14100	Ø14 x 100	✓								15																													
	THE14110	Ø14 x 110	✓								25																													
	THE14120	Ø14 x 120	✓	35																																				
	THE14130	Ø14 x 130	✓	5																																				
	THE14140	Ø14 x 140	✓	15																																				
	THE14160	Ø14 x 160	✓	25																																				
	THE16100	Ø16 x 100	✓	16	18,9 - 20		SW 24	80	80		50				--	--	--	--	--	--	--	--	--	115	100	80	58	20	174	87	180					90				
	THE16150	Ø16 x 150	✓				70																																	
	THE18100	Ø18 x 100	✓			10																																		
	THE18130	Ø18 x 130	✓			40																																		
	THE18160	Ø18 x 160	✓			20																																		
	THE18180	Ø18 x 180	✓			40																																		
THE18200	Ø18 x 200	✓	60																																					

## Allgemeine Einbaukennwerte

## Standard-Einbautiefe ( $h_{ef, std}$ )

## Reduzierte Einbautiefe ( $h_{ef, red}$ )

Familie	Artikelnr.	Abmessung (Buchstabe)	Zulassung	Bohrungsdurchmesser	Bohrlochdurchmesser der zu befestigenden Dicke	Einbauschlüssel	Max. Einbaudrehtorque	Minimaler Achsabstand	Minimaler Abstand zum Rand	Minimale Betondicke	Bohrlochtiefe	Einbautiefe	Effektive Tiefe	Zu befestigende Dicke	Kritischer Achsabstand	Kritischer Abstand zum Rand	Kritischer Achsabstand	Kritischer Abstand zum Rand	Minimale Betondicke	Bohrlochtiefe	Einbautiefe	Effektive Tiefe	Zu befestigende Dicke	Kritischer Achsabstand	Kritischer Abstand zum Rand (Ausbruch)	Kritischer Achsabstand (Spalten)	Kritischer Abstand zum Rand (Spalten)
[--]	[--]	[--]	ETA	[mm]	[mm]	[--]	[Nm]	[mm]	[mm]	[mm]	[mm]	[mm]	[mm]	[mm]	[mm]	[mm]	[mm]	[mm]	[mm]	[mm]	[mm]	[mm]	[mm]	[mm]	[mm]	[mm]	[mm]
THA	THA05040	Ø5 x 40(A)	✓*	5	6,5 - 8	TX25	8	35	35	--	--	--	--	--	--	--	--	--	80	45	35	26,5	5	80	40	80	40
	THA05060	Ø5 x 60(B)	✓*			25																					
	THA05080	Ø5 x 80(D)	✓*			45																					
	THA05100	Ø5 x 100(E)	✓*			65																					
	THA06045	Ø6 x 45	✓	6	7,5 - 9	TX30	10	35	35	--	--	--	--	--	--	--	--	--	100	45	35	26,0	10	78	39	90	45
	THA06050	Ø6 x 50	✓			15																					
	THA06060	Ø6 x 60	✓			25																					
	THA06080	Ø6 x 80	✓			45																					
	THA06100	Ø6 x 100	✓			65																					
	THA06120	Ø6 x 120	✓			85																					
	THA06140	Ø6 x 140	✓	105																							
	THA08060	Ø8 x 60	✓	8	10,5 - 12	TX45	20	35	35	--	--	--	--	--	--	--	--	--	100	60	50	37,5	10	113	57	130	65
THA08080	Ø8 x 80	✓	30																								
THA08100	Ø8 x 100	✓	50																								
THA08120	Ø8 x 120	✓	70																								
THA10100	Ø10 x 100	✓	10	12,5 - 14	TX50	30	50	40	135	95	85	67,0	15	201	101	210	105	100	65	55	41,5	45	125	63	140	70	
THA10120	Ø10 x 120	✓			65																						
THT	THT06040	Ø6 x 40	✓	6	7,5 - 9	TX30	10	35	35	--	--	--	--	--	--	--	--	--	100	45	35	26,0	5	78	39	90	45
	THT06050	Ø6 x 50	✓			15																					
	THT06060	Ø6 x 60	✓			25																					
THP	THP05040	Ø5 x 40(A)	✓*	5	6,5 - 8	TX30	8	35	35	--	--	--	--	--	--	--	--	--	80	45	35	26,5	5	80	40	80	40
	THP05060	Ø5 x 60(B)	✓*			25																					
	THP06040	Ø6 x 40	✓	6	7,5 - 9	TX40	10	35	35	--	--	--	--	--	--	--	--	--	100	45	35	26,0	5	78	39	90	45
	THP06050	Ø6 x 50	✓			15																					
	THP06060	Ø6 x 60	✓			25																					
	THP06080	Ø6 x 80	✓			45																					
	THP06100	Ø6 x 100	✓	65																							
	THP08060	Ø8 x 60	✓	8	10,5 - 12	TX45	20	35	35	--	--	--	--	--	--	--	--	--	100	60	50	37,5	10	113	57	130	65
THP08080	Ø8 x 80	✓	30																								

\*Ø5 Zulassung nur für Verankerungen in Beton und vorgefertigten Spannbeton-Hohldecken für redundante nichttragende Systeme

4. EINBAUPARAMETER (HOHLKÖRPERPLATTEN) [Einbautiefe Reduzierte /Mittel/ Standard]

Allgemeine Einbaukennwerte											Einbautiefe (h <sub>ef1</sub> / h <sub>ef2</sub> / h <sub>ef3</sub> )							
Familie	Artikelnr.	Abmessung (Buchstabe)	Zulassung	Bohrungsdurchmesser	Bohrlochdurchmesser der zu befestigenden	Einbauschlüssel	Max. Einbaudrehrmoment	Minimaler Achsabstand	Minimaler Abstand zum Rand	Bodenstärke der Spannbeton-Hohldecken	Bohrlochtiefe	Einbautiefe	Effektive Tiefe	Zu befestigende Dicke	Kritischer Achsabstand (Ausbruch)	Kritischer Abstand zum Rand (Ausbruch)	Kritischer Achsabstand (Spalten)	Kritischer Abstand zum Rand (Spalten)
[--]	[--]	[--]	ETA	d <sub>0</sub> [mm]	d <sub>f</sub> [mm]	SW/Tx [--]	T <sub>inst</sub> [Nm]	S <sub>min</sub> [mm]	C <sub>min</sub> [mm]	d <sub>b</sub> [mm]	h <sub>1</sub> [mm]	h <sub>nom</sub> [mm]	h <sub>ef</sub> [mm]	t <sub>fix</sub> [mm]	S <sub>cr,N</sub> [mm]	C <sub>cr,N</sub> [mm]	S <sub>cr,sp</sub> [mm]	C <sub>cr,sp</sub> [mm]
THE	THE05040	Ø5 x 40(A)	✓*	5	6,5 - 8	SW 8	8	35	35	25/30/40	30/40/45	30/40/45	20/22/26,5	10/--/--	60/66/80	30/33/40	80	80
	THE05050	Ø5 x 50(A)	✓*			20/10/5												
	THE05060	Ø5 x 60(B)	✓*			30/20/15												
	THE05080	Ø5 x 80(D)	✓*			50/40/35												
	THE05100	Ø5 x 100(E)	✓*			70/60/55												
	THE06035	Ø6 x 35	✓	6	7,5 - 9	SW 10	10	35	35	25/30/40	30/40/45	30/40/45	20/22/26	5/--/--	60/66/78	30/33/39	90	45
	THE06040	Ø6 x 40	✓			10/--/--												
	THE06045	Ø6 x 45	✓			15/5/--												
	THE06050	Ø6 x 50	✓			20/10/5												
	THE06060	Ø6 x 60	✓			30/20/15												
	THE06070	Ø6 x 70	✓			40/30/25												
	THE06080	Ø6 x 80	✓			50/40/35												
THE06100	Ø6 x 100	✓	70/60/55															
THE06120	Ø6 x 120	✓	90/80/75															
THA	THA05040	Ø5 x 40(A)	✓*	5	6,5 - 8	TX25	8	35	35	25/30/40	30/40/45	30/40/45	20/22/26,5	10/--/--	60/66/80	30/33/40	80	80
	THA05060	Ø5 x 60(B)	✓*			30/20/15												
	THA05080	Ø5 x 80(D)	✓*			50/40/35												
	THA05100	Ø5 x 100(E)	✓*			70/60/55												
	THA06045	Ø6 x 45	✓	6	7,5 - 9	TX30	10	35	35	25/30/40	30/40/45	30/40/45	20/22/26	15/5/--	60/66/78	30/33/39	90	45
	THA06050	Ø6 x 50	✓			20/10/5												
	THA06060	Ø6 x 60	✓			30/20/15												
	THA06080	Ø6 x 80	✓			50/40/35												
	THA06100	Ø6 x 100	✓			70/60/55												
	THA06120	Ø6 x 120	✓			90/80/75												
	THA06140	Ø6 x 140	✓			110/100/95												

\*Ø5 Zulassung nur für Verankerungen in Beton und vorgefertigten Spannbeton-Hohldecken für redundante nichttragende Systeme



Allgemeine Einbaukennwerte										Einbautiefe ( $h_{ef1}/ h_{ef2}/ h_{ef3}$ )								
Familie	Artikelnr.	Abmessung (Buchstabe)	Zulassung	Bohrungsdurchmesser	Bohrlochdurchmesser der zu befestigenden	Einbauschlüssel	Max. Einbaudrehmoment	Minimaler Achsabstand	Minimaler Abstand zum Rand	Bodenstärke der Spannbeton-Hohldecken	Bohrlochtiefe	Einbautiefe	Effektive Tiefe	Zu befestigende Dicke	Kritischer Achsabstand (Ausbruch)	Kritischer Abstand zum Rand (Ausbruch)	Kritischer Achsabstand (Spalten)	Kritischer Abstand zum Rand (Spalten)
[--]	[--]	[--]	ETA	$d_0$	$d_f$	SW/Tx	$T_{inst}$	$S_{min}$	$C_{min}$	$d_b$	$h_1$	$h_{nom}$	$h_{ef}$	$t_{fix}$	$S_{cr,N}$	$C_{cr,N}$	$S_{cr,sp}$	$C_{cr,sp}$
				[mm]	[mm]	[--/Tx]	[Nm]	[mm]	[mm]	[mm]	[mm]	[mm]	[mm]	[mm]	[mm]	[mm]	[mm]	[mm]
THT	THT06040	Ø6 x 40	✓	6	7,5 - 9	TX30	10	35	35	25/30/40	30/40/45	30/40/45	20/22/26	10/--/--	60/66/78	30/33/39	90	45
	THT06050	Ø6 x 50	✓			TX30								20/10/5				
	THT06060	Ø6 x 60	✓			TX30								30/20/15				
THP	THP05040	Ø5 x 40(A)	✓*	5	6,5 - 8	TX30	8	35	35	25/30/40	30/40/45	30/40/45	20/22/26,5	10/--/--	60/66/80	30/33/40	80	80
	THP05060	Ø5 x 60(B)	✓*			TX30								30/20/15				
	THP06040	Ø6 x 40	✓	6	7,5 - 9	TX40	10	35	35	25/30/40	30/40/45	30/40/45	20/22/26	10/--/--	60/66/78	30/33/39	90	45
	THP06050	Ø6 x 50	✓			TX40								20/10/5				
	THP06060	Ø6 x 60	✓			TX40								30/20/15				
	THP06080	Ø6 x 80	✓			TX40								50/40/35				
	THP06100	Ø6 x 100	✓			TX40								70/60/55				

\*Ø5 Zulassung nur für Verankerungen in Beton und vorgefertigten Spannbeton-Hohldecken für redundante nichttragende Systeme

**5. EINBAUVERFAHREN**

**5.1 EINBAU IN BETON UND HOHLKÖRPERPLATTEN**

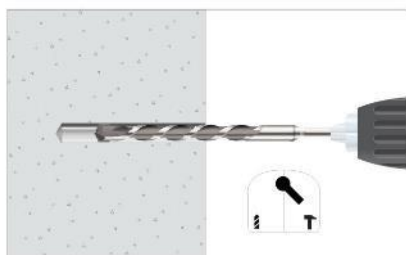

**1. BOHRLOCH ERSTELLEN**

Sicherstellen, dass der Beton ausreichend verdichtet ist und keine bedeutende Porenbildung aufweist.  
Verwendbar mit trockenen, feuchten oder mit Wasser gefüllten Bohrlöchern.  
Bohrlocherstellung mittels Schlag- oder Hammerbohren.  
Das Bohrloch mit dem spezifizierten Durchmesser und der spezifizierten Tiefe erstellen.



**2. AUSBLASEN UND REINIGEN**

Das Bohrloch von Staubresten und Bohrungsrückständen reinigen (siehe Grafik).  
Hierzu eine Luftpumpe und eine Bürste verwenden.

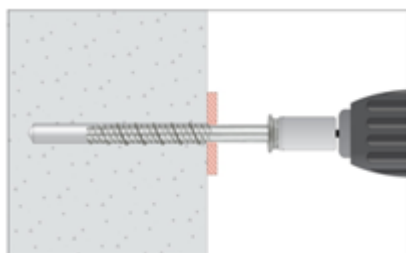

**3. EINBAUEN**

Einen Schlagschrauber verwenden, der das in den obigen Tabellen angegebene maximale Drehmoment nicht überschreitet.  
Für die jeweilige Größe den passenden Innensechskant bzw. das passende Bit verwenden.  
Einbau durch das zu befestigende Material.

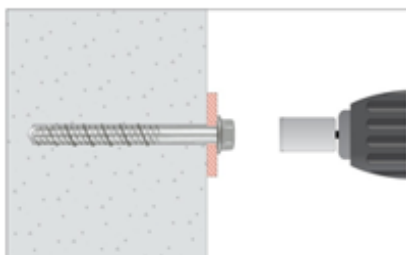

**4. FESTZIEHEN**

Die Verankerung in das Bohrloch einbringen, bis der Kopf bündig mit der Oberfläche des Baustoffs abschließt.  
Der Dübel muss nach der Montage fest sitzen.

## 6. TRAGFÄHIGKEIT

Die Tragfähigkeitswerte in Beton C20/25 für eine einzelne Verankerung ohne Einwirkung von Rand- oder Achsabstand-Effekten werden in der nachfolgenden Tabelle angegeben:

Unterstrichene und kursiv gedruckte Werte geben das Stahlversagen an; die **fett** gedruckten Werte geben das Versagen durch Betonausbruch und die restlichen das Versagen durch Herausziehen an.

1 KN ≈ 100 kg

### 6.1 CHARAKTERISTISCHE FESTIGKEIT (TRAGENDE ANWENDUNGEN)[kN]

Allgemeine Parameter				Ungerissener Beton				Gerissener Beton											
Familie	Artikelnr.	Größe	ETA-Zulassung	Zuglast $N_{Rk, ucr}$		Querlast $V_{Rk, ucr}$		Zuglast $N_{Rk, cr}$		Querlast $V_{Rk, cr}$									
				( $h_{ef, std}$ )	( $h_{ef, red}$ )	( $h_{ef, std}$ )	( $h_{ef, red}$ )	( $h_{ef, std}$ )	( $h_{ef, red}$ )	( $h_{ef, std}$ )	( $h_{ef, red}$ )								
THE	THE05040	Ø5 x 40	✓*	--	<b>6,71</b>	--	<b>6,71</b>	--	<b>4,70</b>	--	<b>4,70</b>								
	THE05050	Ø5 x 50	✓*	<b>10,19</b>	<b>6,71</b>	<u>8,19</u>	<b>6,71</b>	<b>7,13</b>	<b>4,70</b>	<b>7,13</b>	<b>4,70</b>								
	THE05060	Ø5 x 60	✓*																
	THE05080	Ø5 x 80	✓*																
	THE05100	Ø5 x 100	✓*																
	THE06035	Ø6 x 35	✓	--	5,00	--	<u>12,53</u>	--	<b>4,57</b>	--	<b>9,36</b>								
	THE06040	Ø6 x 40	✓																
	THE06045	Ø6 x 45	✓																
	THE06050	Ø6 x 50	✓																
	THE06060	Ø6 x 60	✓	<b>13,87</b>	5,00	<u>12,53</u>	<u>12,53</u>	<b>9,71</b>	<b>4,57</b>	<b>11,17</b>	<b>9,36</b>								
	THE06070	Ø6 x 70	✓																
	THE06080	Ø6 x 80	✓																
	THE06100	Ø6 x 100	✓																
	THE06120	Ø6 x 120	✓																
	THE08055	Ø8 x 55	✓									--	<b>11,30</b>	--	<u>19,57</u>	--	<b>7,91</b>	--	<b>14,23</b>
	THE08060	Ø8 x 60	✓																
	THE08070	Ø8 x 70	✓	<b>17,65</b>	<b>11,30</b>	<u>19,57</u>	<u>19,57</u>	<b>12,36</b>	<b>7,91</b>	<b>15,69</b>	<b>14,23</b>								
	THE08075	Ø8 x 75	✓																
	THE08080	Ø8 x 80	✓																
	THE08090	Ø8 x 90	✓																
	THE08100	Ø8 x 100	✓																
	THE08110	Ø8 x 110	✓																
	THE08120	Ø8 x 120	✓																
	THE08140	Ø8 x 140	✓	<b>26,98</b>	<b>13,15</b>	<u>27,40</u>	<b>25,65</b>	<b>18,89</b>	<b>9,21</b>	<u>27,40</u>	<b>17,95</b>								
	THE10060	Ø10 x 60	✓																
	THE10070	Ø10 x 70	✓																
	THE10080	Ø10 x 80	✓																
	THE10090	Ø10 x 90	✓																
	THE10100	Ø10 x 100	✓																
	THE10120	Ø10 x 120	✓																
	THE10140	Ø10 x 140	✓																
	THE10160	Ø10 x 160	✓																
	THE10180	Ø10 x 180	✓																
	THE12080	Ø12 x 80	✓	--	<b>21,73</b>	--	<u>37,24</u>	--	<b>15,21</b>	--	<b>35,44</b>								
	THE12090	Ø12 x 90	✓																
	THE12100	Ø12 x 100	✓	<b>37,54</b>	<b>21,73</b>	<u>37,24</u>	<u>37,24</u>	<b>26,27</b>	<b>15,21</b>	<u>37,24</u>	<b>35,44</b>								
	THE12110	Ø12 x 110	✓																
	THE12130	Ø12 x 130	✓																
	THE12150	Ø12 x 150	✓																
	THE14080	Ø14 x 80	✓	--	<b>21,73</b>	--	<u>52,72</u>	--	<b>15,21</b>	--	<b>38,79</b>								
THE14100	Ø14 x 100	✓																	
THE14110	Ø14 x 110	✓	<b>43,41</b>	<b>21,73</b>	<u>52,72</u>	<u>52,72</u>	<b>30,39</b>	<b>15,21</b>	<u>52,72</u>	<b>38,79</b>									
THE14120	Ø14 x 120	✓																	
THE14130	Ø14 x 130	✓																	
THE14140	Ø14 x 140	✓																	
THE14160	Ø14 x 160	✓																	
TFE16100	Ø16 x 100	✓	--	--	--	--	<b>30,39</b>	<b>15,21</b>	<u>52,72</u>	<b>32,55</b>									
THE16150	Ø16 x 150	✓	<b>43,41</b>	<b>21,73</b>	<u>57,97</u>	<b>46,50</b>	<b>30,39</b>	<b>15,21</b>	<u>52,72</u>	<b>32,55</b>									
THE18100	Ø18 x 100	✓	--	<b>28,50</b>	--	<b>75,82</b>					--	<b>19,95</b>	--	<b>53,07</b>					
THE18130	Ø18 x 130	✓																	
THE18160	Ø18 x 160	✓	<b>58,31</b>	<b>28,50</b>	<u>80,78</u>	<b>75,82</b>	<b>40,82</b>	<b>19,95</b>	<u>80,78</u>	<b>53,07</b>									
THE18180	Ø18 x 180	✓																	
THE18200	Ø18 x 200	✓																	

Allgemeine Parameter				Ungerissener Beton				Gerissener Beton											
Familie	Artikelnr.	Größe	ETA-Zulassung	Zuglast $N_{Rk, ucr}$		Querlast $V_{Rk, ucr}$		Zuglast $N_{Rk, cr}$		Querlast $V_{Rk, cr}$									
				( $h_{ef, sta}$ )	( $h_{ef, red}$ )	( $h_{ef, sta}$ )	( $h_{ef, red}$ )	( $h_{ef, sta}$ )	( $h_{ef, red}$ )	( $h_{ef, sta}$ )	( $h_{ef, red}$ )								
THA	THA05040	Ø5 x 40	✓*	--	6,71	--	6,71	--	4,70	--	4,70								
	THA05060	Ø5 x 60	✓*	10,19	6,71	<u>8,19</u>	6,71	7,13	4,70	7,13	4,70								
	THA05080	Ø5 x 80	✓*																
	THA05100	Ø5 x 100	✓*																
	THA06045	Ø6 x 45	✓	--	5,00	--	<u>12,53</u>	--	4,57	--	9,36								
	THA06050	Ø6 x 50	✓	--		--		--											
	THA06060	Ø6 x 60	✓	13,87	5,00	<u>12,53</u>	<u>12,53</u>	9,71	4,57	11,17	9,36								
	THA06080	Ø6 x 80	✓																
	THA06100	Ø6 x 100	✓																
	THA06120	Ø6 x 120	✓																
	THA06140	Ø6 x 140	✓	17,65	11,30	<u>19,57</u>	<u>19,57</u>	12,36	7,91	15,69	14,23								
	THA08060	Ø8 x 60	✓									--	11,30	--	<u>19,57</u>	--	7,91	--	14,23
	THA08080	Ø8 x 80	✓									17,65	11,30	<u>19,57</u>	<u>19,57</u>	12,36	7,91	15,69	14,23
	THA08100	Ø8 x 100	✓																
THA08120	Ø8 x 120	✓	26,98	13,15	<u>27,40</u>	25,65	18,89	9,21	<u>27,40</u>	17,95									
THA10100	Ø10 x 100	✓																	
THA10120	Ø10 x 120	✓																	
THT	THT06040	Ø6 x 40	✓	--	5,00	--	<u>12,53</u>	--	4,57	--	9,36								
	THT06050	Ø6 x 50	✓	--		--		--											
	THT06060	Ø6 x 60	✓	13,87	5,00	<u>12,53</u>	<u>12,53</u>	9,71	4,57	11,17	9,36								
THP	THP05040	Ø5 x 40	✓*	--	6,71	--	6,71	--	4,70	--	4,70								
	THP05060	Ø5 x 60	✓*	10,19	6,71	<u>8,19</u>	6,71	7,13	4,70	7,13	4,70								
	THP06040	Ø6 x 40	✓	--	5,00	--	<u>12,53</u>	9,71	4,57	--	9,36								
	THP06050	Ø6 x 50	✓	--		--		--											
	THP06060	Ø6 x 60	✓	13,87	5,00	<u>12,53</u>	<u>12,53</u>	9,71	4,57	11,17	9,36								
	THP06080	Ø6 x 80	✓																
	THP06100	Ø6 x 100	✓																
	THP08060	Ø8 x 60	✓	--	11,30	--	<u>19,57</u>	--	7,91	--	14,23								
THP08080	Ø8 x 80	✓	17,65	11,30	<u>19,57</u>	<u>19,57</u>	12,36	7,91	15,69	14,23									

\*Ø5 Zulassung nur für Verankerungen in Beton und vorgefertigten Spannbeton-Hohldecken für redundante nichttragende Systeme

6.2 BEMESSUNGSWERTE DER FESTIGKEIT (TRAGENDE ANWENDUNGEN)[kN]

Allgemeine Parameter				Ungerissener Beton				Gerissener Beton			
Familie	Artikelnr.	Größe	ETA-Zulassung	Zuglast $N_{Rd,ucr}$		Querlast $V_{Rd,ucr}$		Zuglast $N_{Rd,cr}$		Querlast $V_{Rd,cr}$	
				( $h_{ef,sta}$ )	( $h_{ef,red}$ )	( $h_{ef,sta}$ )	( $h_{ef,red}$ )	( $h_{ef,sta}$ )	( $h_{ef,red}$ )	( $h_{ef,sta}$ )	( $h_{ef,red}$ )
THE	THE05040	Ø5 x 40	✓*	--	4,47	--	4,47	--	3,13	--	3,13
	THE05050	Ø5 x 50	✓*	6,79	4,47	<u>5,46</u>	4,47	4,75	3,13	4,75	3,13
	THE05060	Ø5 x 60	✓*								
	THE05080	Ø5 x 80	✓*								
	THE05100	Ø5 x 100	✓*								
	THE06035	Ø6 x 35	✓	--	2,78	--	<u>8,35</u>	--	2,54	--	6,24
	THE06040	Ø6 x 40	✓	--		--					
	THE06045	Ø6 x 45	✓	--		--					
	THE06050	Ø6 x 50	✓	--		--					
	THE06060	Ø6 x 60	✓	9,25	2,78	<u>8,35</u>	<u>8,35</u>	6,47	2,54	7,44	6,24
	THE06070	Ø6 x 70	✓								
	THE06080	Ø6 x 80	✓								
	THE06100	Ø6 x 100	✓								
	THE06120	Ø6 x 120	✓	11,77	6,28	<u>13,05</u>	<u>13,05</u>	8,24	4,39	10,46	9,49
	THE08055	Ø8 x 55	✓								
	THE08060	Ø8 x 60	✓								
	THE08070	Ø8 x 70	✓								
	THE08075	Ø8 x 75	✓								
	THE08080	Ø8 x 80	✓								
	THE08090	Ø8 x 90	✓								
	THE08100	Ø8 x 100	✓								
	THE08110	Ø8 x 110	✓								
	THE08120	Ø8 x 120	✓	17,99	8,77	<u>18,27</u>	17,10	12,59	6,14	<u>18,27</u>	11,97
	THE08140	Ø8 x 140	✓								
	THE10060	Ø10 x 60	✓								
	THE10070	Ø10 x 70	✓								
	THE10080	Ø10 x 80	✓	--	21,73	--	<u>52,72</u>	--	15,21	--	38,79
	THE10090	Ø10 x 90	✓								
	THE10100	Ø10 x 100	✓								
	THE10120	Ø10 x 120	✓								
	THE10140	Ø10 x 140	✓	43,41	21,73	<u>52,72</u>	<u>52,72</u>	30,39	15,21	<u>52,72</u>	38,79
	THE10160	Ø10 x 160	✓								
THE10180	Ø10 x 180	✓									
THE12080	Ø12 x 80	✓									
THE12090	Ø12 x 90	✓	--	14,49	--	<u>24,83</u>	--	10,14	--	23,63	
THE12100	Ø12 x 100	✓									
THE12110	Ø12 x 110	✓									
THE12130	Ø12 x 130	✓									
THE12150	Ø12 x 150	✓	25,02	14,49	<u>24,83</u>	<u>24,83</u>	17,52	10,14	<u>24,83</u>	23,63	
THE14080	Ø14 x 80	✓									
THE14100	Ø14 x 100	✓									
THE14110	Ø14 x 110	✓									
THE14120	Ø14 x 120	✓	43,41	21,73	<u>52,72</u>	<u>52,72</u>	30,39	15,21	<u>52,72</u>	38,79	
THE14130	Ø14 x 130	✓									
THE14140	Ø14 x 140	✓									
THE14160	Ø14 x 160	✓									
TFE16100	Ø16 x 100	✓	--	--	--	--	20,26	10,14	<u>38,65</u>	21,70	
TFE16150	Ø16 x 150	✓	28,94	14,49	<u>38,65</u>	31,00					
THE18100	Ø18 x 100	✓	--	19,00	--	50,54	--	13,30	--	35,38	
THE18130	Ø18 x 130	✓									
THE18160	Ø18 x 160	✓									
THE18180	Ø18 x 180	✓									
THE18200	Ø18 x 200	✓	38,87	19,00	<u>53,85</u>	50,54	27,21	13,30	<u>53,85</u>	35,38	

Allgemeine Parameter				Ungerissener Beton				Gerissener Beton			
Familie	Artikelnr.	Größe	ETA-Zulassung	Zuglast $N_{Rd,ucr}$		Querlast $V_{Rd,ucr}$		Zuglast $N_{Rd,cr}$		Querlast $V_{Rd,cr}$	
				( $h_{ef,sta}$ )	( $h_{ef,red}$ )	( $h_{ef,sta}$ )	( $h_{ef,red}$ )	( $h_{ef,sta}$ )	( $h_{ef,red}$ )	( $h_{ef,sta}$ )	( $h_{ef,red}$ )
THA	THA05040	Ø5 x 40	✓*	--	4,47	--	4,47	--	3,13	--	3,13
	THA05060	Ø5 x 60	✓*	6,79	4,47	<u>5,46</u>	4,47	4,75	3,13	4,75	3,13
	THA05080	Ø5 x 80	✓*								
	THA05100	Ø5 x 100	✓*								
	THA06045	Ø6 x 45	✓	--	2,78	--	<u>8,35</u>	--	2,54	--	6,24
	THA06050	Ø6 x 50	✓								
	THA06060	Ø6 x 60	✓	9,25	2,78	<u>8,35</u>	<u>8,35</u>	6,47	2,54	7,44	6,24
	THA06080	Ø6 x 80	✓								
	THA06100	Ø6 x 100	✓								
	THA06120	Ø6 x 120	✓								
	THA06140	Ø6 x 140	✓								
	THA08060	Ø8 x 60	✓	--	6,28	--	<u>13,05</u>	--	4,39	--	9,49
	THA08080	Ø8 x 80	✓	11,77	6,28	<u>13,05</u>	<u>13,05</u>	8,24	4,39	10,46	9,49
	THA08100	Ø8 x 100	✓								
THA08120	Ø8 x 120	✓									
THA10100	Ø10 x 100	✓	17,99	8,77	<u>18,27</u>	17,10	12,59	6,14	<u>18,27</u>	11,97	
THA10120	Ø10 x 120	✓									
THT	THT06040	Ø6 x 40	✓	--	2,78	--	<u>8,35</u>	--	2,54	--	6,24
	THT06050	Ø6 x 50	✓								
	THT06060	Ø6 x 60	✓	9,25	2,78	<u>8,35</u>	<u>8,35</u>	6,47	2,54	7,44	6,24
THP	THP05040	Ø5 x 40	✓*	--	4,47	--	4,47	--	3,13	--	3,13
	THP05060	Ø5 x 60	✓*	6,79	4,47	<u>5,46</u>	4,47	4,75	3,13	4,75	3,13
	THP06040	Ø6 x 40	✓	--	2,78	--	<u>8,35</u>	--	2,54	--	6,24
	THP06050	Ø6 x 50	✓								
	THP06060	Ø6 x 60	✓	9,25	2,78	<u>8,35</u>	<u>8,35</u>	6,47	2,54	7,44	6,24
	THP06080	Ø6 x 80	✓								
	THP06100	Ø6 x 100	✓								
	THP08060	Ø8 x 60	✓	--	6,28	--	<u>13,05</u>	--	4,39	--	9,49
THP08080	Ø8 x 80	✓	11,77	6,28	<u>13,05</u>	<u>13,05</u>	8,24	4,39	10,46	9,49	

\*Ø5 Zulassung nur für Verankerungen in Beton und vorgefertigten Spannbeton-Hohldecken für redundante nichttragende Systeme

**6.3 MAX. EMPFOHLENE ZUGFESTIGKEIT (TRAGENDE ANWENDUNGEN) [kN] (wenn  $\gamma_F=1,4$ ) [kN]**

Allgemeine Parameter				Ungerissener Beton				Gerissener Beton			
Familie	Artikelnr.	Größe	ETA-Zulassung	Zuglast $N_{rec, ucr}$		Querlast $V_{rec, ucr}$		Zuglast $N_{rec, cr}$		Querlast $V_{rec, cr}$	
				( $h_{ef, std}$ )	( $h_{ef, red}$ )	( $h_{ef, std}$ )	( $h_{ef, red}$ )	( $h_{ef, std}$ )	( $h_{ef, red}$ )	( $h_{ef, std}$ )	( $h_{ef, red}$ )
THE	THE05040	Ø5 x 40	✓*	--	3,20	--	3,20	--	2,24	--	2,24
	THE05050	Ø5 x 50	✓*	4,85	3,20	<u>3,90</u>	3,20	3,40	2,24	3,40	2,24
	THE05060	Ø5 x 60	✓*								
	THE05080	Ø5 x 80	✓*								
	THE05100	Ø5 x 100	✓*								
	THE06035	Ø6 x 35	✓	--	1,98	--	<u>5,97</u>	--	1,81	--	4,46
	THE06040	Ø6 x 40	✓	--		--					
	THE06045	Ø6 x 45	✓	--		--					
	THE06050	Ø6 x 50	✓	--		--					
	THE06060	Ø6 x 60	✓	6,61	1,98	<u>5,97</u>	<u>5,97</u>	4,62	1,81	5,32	4,46
	THE06070	Ø6 x 70	✓								
	THE06080	Ø6 x 80	✓								
	THE06100	Ø6 x 100	✓								
	THE06120	Ø6 x 120	✓	8,41	4,48	<u>9,32</u>	<u>9,32</u>	5,88	3,14	7,47	6,78
	THE08055	Ø8 x 55	✓								
	THE08060	Ø8 x 60	✓								
	THE08070	Ø8 x 70	✓								
	THE08075	Ø8 x 75	✓								
	THE08080	Ø8 x 80	✓								
	THE08090	Ø8 x 90	✓								
	THE08100	Ø8 x 100	✓								
	THE08110	Ø8 x 110	✓								
	THE08120	Ø8 x 120	✓	12,85	6,26	<u>13,05</u>	12,21	8,99	4,38	<u>13,05</u>	8,55
	THE08140	Ø8 x 140	✓								
	THE10060	Ø10 x 60	✓								
	THE10070	Ø10 x 70	✓								
	THE10080	Ø10 x 80	✓	--	6,26	--	12,21	--	4,38	--	8,55
	THE10090	Ø10 x 90	✓	--		--					
	THE10100	Ø10 x 100	✓	--		--					
	THE10120	Ø10 x 120	✓	--		--					
	THE10140	Ø10 x 140	✓	17,87	10,35	<u>17,73</u>	<u>17,73</u>	12,51	7,24	<u>17,73</u>	16,88
	THE10160	Ø10 x 160	✓								
THE10180	Ø10 x 180	✓									
THE12080	Ø12 x 80	✓									
THE12090	Ø12 x 90	✓	--	10,35	--	<u>17,73</u>	--	7,24	--	16,88	
THE12100	Ø12 x 100	✓	--		--						
THE12110	Ø12 x 110	✓	--		--						
THE12130	Ø12 x 130	✓	--		--						
THE12150	Ø12 x 150	✓	20,67	10,35	<u>25,10</u>	<u>25,10</u>	14,47	7,24	<u>25,10</u>	18,47	
THE14080	Ø14 x 80	✓									
THE14100	Ø14 x 100	✓									
THE14110	Ø14 x 110	✓									
THE14120	Ø14 x 120	✓	27,77	13,57	<u>38,47</u>	36,10	19,44	9,50	<u>38,47</u>	25,27	
THE14130	Ø14 x 130	✓									
THE14140	Ø14 x 140	✓									
THE14160	Ø14 x 160	✓									
TFE16100	Ø16 x 100	✓	--	--	--	--	14,47	7,24	<u>27,60</u>	15,50	
TFE16150	Ø16 x 150	✓	20,67	10,35	<u>27,60</u>	22,14					
THE18100	Ø18 x 100	✓	--	13,57	--	36,10	--	9,50	--	25,27	
THE18130	Ø18 x 130	✓	--		--						
THE18160	Ø18 x 160	✓	--		--						
THE18180	Ø18 x 180	✓	--		--						
THE18200	Ø18 x 200	✓	27,77	13,57	<u>38,47</u>	36,10	19,44	9,50	<u>38,47</u>	25,27	

Allgemeine Parameter				Ungerissener Beton				Gerissener Beton			
Familie	Artikelnr.	Größe	ETA-Zulassung	Zuglast $N_{rec, ucr}$		Querlast $V_{rec, ucr}$		Zuglast $N_{rec, cr}$		Querlast $V_{rec, cr}$	
				( $h_{ef, std}$ )	( $h_{ef, red}$ )	( $h_{ef, std}$ )	( $h_{ef, red}$ )	( $h_{ef, std}$ )	( $h_{ef, red}$ )	( $h_{ef, std}$ )	( $h_{ef, red}$ )
THA	THA05040	Ø5 x 40	✓*	--	3,20	--	3,20	--	2,24	--	2,24
	THA05060	Ø5 x 60	✓*	4,85	3,20	<u>3,90</u>	3,20	3,40	2,24	3,40	2,24
	THA05080	Ø5 x 80	✓*								
	THA05100	Ø5 x 100	✓*								
	THA06045	Ø6 x 45	✓	--	1,98	--	<u>5,97</u>	--	1,81	--	4,46
	THA06050	Ø6 x 50	✓	6,61	1,98	<u>5,97</u>	<u>5,97</u>	4,62	1,81	5,32	4,46
	THA06060	Ø6 x 60	✓								
	THA06080	Ø6 x 80	✓								
	THA06100	Ø6 x 100	✓								
	THA06120	Ø6 x 120	✓								
	THA06140	Ø6 x 140	✓	8,41	4,48	<u>9,32</u>	<u>9,32</u>	5,88	3,14	7,47	6,78
	THA08060	Ø8 x 60	✓								
	THA08080	Ø8 x 80	✓								
	THA08100	Ø8 x 100	✓								
THA08120	Ø8 x 120	✓									
THA10100	Ø10 x 100	✓	12,85								
THA10120	Ø10 x 120	✓									
THT06040	Ø6 x 40	✓		--	1,98	--	<u>5,97</u>	--	1,81	--	4,46
THT	THT06050	Ø6 x 50	✓	6,61	1,98	<u>5,97</u>	<u>5,97</u>	4,62	1,81	5,32	4,46
	THT06060	Ø6 x 60	✓								
	THP05040	Ø5 x 40	✓*								
THP	THP05060	Ø5 x 60	✓*	4,85	3,20	<u>3,90</u>	3,20	3,40	2,24	3,40	2,24
	THP06040	Ø6 x 40	✓								
	THP06050	Ø6 x 50	✓	--	1,98	--	<u>5,97</u>	--	1,81	--	4,46
	THP06060	Ø6 x 60	✓	6,61	1,98	<u>5,97</u>	<u>5,97</u>	4,62	1,81	5,32	4,46
	THP06080	Ø6 x 80	✓								
	THP06100	Ø6 x 100	✓								
	THP08060	Ø8 x 60	✓	--	4,48	--	<u>9,32</u>	--	3,14	--	6,78
	THP08080	Ø8 x 80	✓	8,41	4,48	<u>9,32</u>	<u>9,32</u>	5,88	3,14	7,47	6,78

\*Ø5 Zulassung nur für Verankerungen in Beton und vorgefertigten Spannbeton-Hohldecken für redundante nichttragende Systeme

VERGRÖßERUNGSFAKTOREN FÜR HERAUSZIEHEN UNTER ZUGBEANSPRUCHUNG FÜR HOCHFESTEN BETON $\psi_c$															
Durchmesser	Ø5		Ø6		Ø8		Ø10			Ø12		Ø14		Ø18	
Einbautiefe	( $h_{ef, red}$ )	( $h_{ef, std}$ )	( $h_{ef, red}$ )	( $h_{ef, std}$ )	( $h_{ef, red}$ )	( $h_{ef, std}$ )	( $h_{ef, 1}$ )	( $h_{ef, 2}$ )	( $h_{ef, 3}$ )	( $h_{ef, red}$ )	( $h_{ef, std}$ )	( $h_{ef, red}$ )	( $h_{ef, std}$ )	( $h_{ef, red}$ )	( $h_{ef, std}$ )
C30/37	1,00	1,00	1,16	1,22	1,21	1,22	1,22	1,17	1,22	1,16	1,22	1,21	1,20	1,22	1,17
C40/50	1,00	1,00	1,28	1,41	1,39	1,41	1,41	1,30	1,41	1,29	1,41	1,39	1,37	1,40	1,32
C50/60	1,00	1,00	1,39	1,58	1,54	1,58	1,58	1,42	1,58	1,40	1,58	1,55	1,51	1,57	1,42



## 7. TRAGFÄHIGKEIT

Die Tragfähigkeitswerte in Hohlkörperplatten C30/37 für eine einzelne Verankerung ohne Einwirkung von Rand- oder Achsabstand-Effekten werden in der nachfolgenden Tabelle angegeben:

Unterstrichene und kursiv gedruckte Werte geben das Stahlversagen an; die **fett** gedruckten Werte geben das Versagen durch Betonausbruch und die restlichen das Versagen durch Herausziehen an.

1 KN ≈ 100 kg

### 7.1 CHARAKTERISTISCHE FESTIGKEIT (NICHT TRAGENDE ANWENDUNGEN)[kN]

Allgemeine Parameter				Hohlkörperplatten					
Familie	Artikelnr.	Größe	ETA-Zulassung	Zuglast N <sub>Rk</sub>			Querlast V <sub>Rk</sub>		
				(h <sub>ef1</sub> )	(h <sub>ef2</sub> )	(h <sub>ef3</sub> )	(h <sub>ef1</sub> )	(h <sub>ef2</sub> )	(h <sub>ef3</sub> )
THE	THE05040	Ø5 x 40	✓*	5,39	--	--	5,39	--	--
	THE05050	Ø5 x 50	✓*		--	--		--	--
	THE05060	Ø5 x 60	✓*		6,22	8,22		6,22	<u>8,19</u>
	THE05080	Ø5 x 80	✓*						
	THE05100	Ø5 x 100	✓*						
	THE06035	Ø6 x 35	✓	5,39	--	--	5,39	--	--
	THE06040	Ø6 x 40	✓		--	--		--	--
	THE06045	Ø6 x 45	✓		--	--		--	--
	THE06050	Ø6 x 50	✓		6,22	7,99		6,22	7,99
	THE06060	Ø6 x 60	✓						
	THE06070	Ø6 x 70	✓						
	THE06080	Ø6 x 80	✓						
	THE06100	Ø6 x 100	✓						
	THE06120	Ø6 x 120	✓						
THA	THA05040	Ø5 x 40	✓*	5,39	--	--	5,39	--	--
	THA05060	Ø5 x 60	✓*		6,22	8,22		6,22	<u>8,19</u>
	THA05080	Ø5 x 80	✓*						
	THA05100	Ø5 x 100	✓*						
	THA06045	Ø6 x 45	✓	5,39	--	--	5,39	--	--
	THA06050	Ø6 x 50	✓		--	--		--	--
	THA06060	Ø6 x 60	✓		6,22	7,99		6,22	7,99
	THA06080	Ø6 x 80	✓						
	THA06100	Ø6 x 100	✓						
THT	THT06040	Ø6 x 40	✓	5,39	--	--	5,39	--	--
	THT06050	Ø6 x 50	✓		6,22	7,99		6,22	7,99
	THT06060	Ø6 x 60	✓						
THP	THP05040	Ø5 x 40	✓*	5,39	--	--	5,39	--	--
	THP05060	Ø5 x 60	✓*		6,22	8,22		6,22	<u>8,19</u>
	THP06040	Ø6 x 40	✓	5,39	--	--	5,39	--	--
	THP06050	Ø6 x 50	✓		6,22	7,99		6,22	7,99
	THP06060	Ø6 x 60	✓						
	THP06080	Ø6 x 80	✓						
THP06100	Ø6 x 100	✓							

\*Ø5 Zulassung nur für Verankerungen in Beton und vorgefertigten Spannbeton-Hohldecken für redundante nichttragende Systeme

7.2 BEMESSUNGSWERTE DER FESTIGKEIT (NICHT TRAGENDE ANWENDUNGEN) [kN]									
Allgemeine Parameter				Hohlkörperplatten					
Familie	Artikelnr.	Größe	ETA-Zulassung	Zuglast $N_{Rd}$			Querlast $V_{Rd}$		
				( $h_{ef1}$ )	( $h_{ef2}$ )	( $h_{ef3}$ )	( $h_{ef1}$ )	( $h_{ef2}$ )	( $h_{ef3}$ )
THE	THE05040	Ø5 x 40	✓*	2,99	--	--	3,59	--	--
	THE05050	Ø5 x 50	✓*		--	--		--	--
	THE05060	Ø5 x 60	✓*		3,45	4,57		4,14	5,46
	THE05080	Ø5 x 80	✓*						
	THE05100	Ø5 x 100	✓*						
	THE06035	Ø6 x 35	✓	2,99	--	--	3,59	--	--
	THE06040	Ø6 x 40	✓		--	--		--	--
	THE06045	Ø6 x 45	✓						
	THE06050	Ø6 x 50	✓						
	THE06060	Ø6 x 60	✓		3,45	4,44		4,14	5,33
	THE06070	Ø6 x 70	✓						
	THE06080	Ø6 x 80	✓						
THE06100	Ø6 x 100	✓							
THE06120	Ø6 x 120	✓							
THA	THA05040	Ø5 x 40	✓*	2,99	--	--	3,59	--	--
	THA05060	Ø5 x 60	✓*		3,45	4,57		4,14	5,46
	THA05080	Ø5 x 80	✓*						
	THA05100	Ø5 x 100	✓*						
	THA06045	Ø6 x 45	✓	2,99		--	3,59	--	
	THA06050	Ø6 x 50	✓			--		--	
	THA06060	Ø6 x 60	✓						
	THA06080	Ø6 x 80	✓		3,45	4,44		4,14	5,33
	THA06100	Ø6 x 100	✓						
THA06120	Ø6 x 120	✓							
THA06140	Ø6 x 140	✓							
THT	THT06040	Ø6 x 40	✓	2,99	--	--	3,59	--	--
	THT06050	Ø6 x 50	✓		3,45	4,44		4,14	5,33
	THT06060	Ø6 x 60	✓						
THP	THP05040	Ø5 x 40	✓*	2,99	--	--	3,59	--	--
	THP05060	Ø5 x 60	✓*		3,45	4,57		4,14	5,46
	THP06040	Ø6 x 40	✓	2,99	--	--	3,59	--	--
	THP06050	Ø6 x 50	✓						
	THP06060	Ø6 x 60	✓		3,45	4,44		4,14	5,33
	THP06080	Ø6 x 80	✓						
THP06100	Ø6 x 100	✓							

\*Ø5 Zulassung nur für Verankerungen in Beton und vorgefertigten Spannbeton-Hohldecken für redundante nichttragende Systeme

7.3 MAX. EMPFOHLENE ZUGFESTIGKEIT (NICHT TRAGENDE ANWENDUNGEN) [kN] (wenn $\gamma_F= 1,4$ ) [kN]									
Allgemeine Parameter				Hohlkörperplatten					
Familie	Artikelnr.	Größe	ETA-Zulassung	Zuglast $N_{rec}$			Querlast $V_{rec}$		
				( $h_{ef1}$ )	( $h_{ef2}$ )	( $h_{ef3}$ )	( $h_{ef1}$ )	( $h_{ef2}$ )	( $h_{ef3}$ )
THE	THE05040	Ø5 x 40	✓*	2,14	--	--	2,57	--	--
	THE05050	Ø5 x 50	✓*		--	--		--	--
	THE05060	Ø5 x 60	✓*		2,47	3,26		2,96	3,90
	THE05080	Ø5 x 80	✓*						
	THE05100	Ø5 x 100	✓*						
	THE06035	Ø6 x 35	✓	2,14	--	--	2,57	--	--
	THE06040	Ø6 x 40	✓		--	--		--	--
	THE06045	Ø6 x 45	✓						
	THE06050	Ø6 x 50	✓						
	THE06060	Ø6 x 60	✓		2,47	3,17		2,96	3,80
	THE06070	Ø6 x 70	✓						
	THE06080	Ø6 x 80	✓						
THE06100	Ø6 x 100	✓							
THE06120	Ø6 x 120	✓							
THA	THA05040	Ø5 x 40	✓*	2,14	--	--	2,57	--	--
	THA05060	Ø5 x 60	✓*		--	--		--	--
	THA05080	Ø5 x 80	✓*		2,47	3,26		2,96	3,90
	THA05100	Ø5 x 100	✓*						
	THA06045	Ø6 x 45	✓	2,14		--	2,57	--	
	THA06050	Ø6 x 50	✓			--		--	--
	THA06060	Ø6 x 60	✓						
	THA06080	Ø6 x 80	✓		2,47	3,17		2,96	3,80
	THA06100	Ø6 x 100	✓						
	THA06120	Ø6 x 120	✓						
THT	THT06040	Ø6 x 40	✓	2,14	--	--	2,57	--	--
	THT06050	Ø6 x 50	✓		2,47	3,17		2,96	3,80
	THT06060	Ø6 x 60	✓						
THP	THP05040	Ø5 x 40	✓*	2,14	--	--	2,57	--	--
	THP05060	Ø5 x 60	✓*		2,47	3,26		2,96	3,90
	THP06040	Ø6 x 40	✓	2,14	--	--	2,57	--	--
	THP06050	Ø6 x 50	✓						
	THP06060	Ø6 x 60	✓		2,47	3,17		2,96	3,80
	THP06080	Ø6 x 80	✓						
	THP06100	Ø6 x 100	✓						

\*Ø5 Zulassung nur für Verankerungen in Beton und vorgefertigten Spannbeton-Hohldecken für redundante nichttragende Systeme

## 8. OFFIZIELLE DOKUMENTE

Bei unserer Vertriebsabteilung oder über unsere Website [www.indexfix.com](http://www.indexfix.com) können Sie folgende Dokument erhalten:

- EU-Zulassung ETA 20/0046 für den Einbau in gerissenem und ungerissenem Beton gemäß EAD 330232-01-0601, Option 1, von Ø6 bis Ø18.
- Europäische Zulassung ETA 20/0494 für die Verwendung in Beton- und Fertigteil-Hohlkörperplatten für redundante nichttragende Systeme gemäß EAD-Richtlinie 330747-00-0601 von Ø5 bis Ø6.
- Leistungserklärung DoP THE.
- Erfüllt die Richtlinie VdS CEA 4001:2021-01(07) „Richtlinien für Sprinkleranlagen. Planung und Einbau für Anwendungen von Wasserlöschanlagen auf Betonelementen“ von Ø8 bis Ø18.
- Erhältlich für das Berechnungsprogramm für Verankerungen INDEXcal.