



GP-Z



GP-G



GP-A2



GP-PL



GP-PVC



GP-O / GL-O



SP-Z



SP-V



SP-H



SP-HX

CARACTERISTIQUES

- Gamme de profilés galvanisés standard: pour charges moyennes de tuyauteries pour fluides
- Ils offrent une grande versatilité pour leur mise en œuvre : suspendus, fixés directement au mur, fixés à d'autres supports perforés, etc.
- Ils sont compatibles avec toute la gamme de colliers du catalogue, pouvant s'utiliser aussi bien avec les colliers pour tuyauteries qu'avec les colliers pour câblage électrique.
- Idéal pour les spécialistes de ce type d'installation.
- Ils présentent différentes finitions:
 - Galvanisés: pour supports d'installations électriques ou d'installations simples de fluides en intérieurs ou extérieurs avec niveau de corrosion modéré.
 - Inoxydables: pour un emploi en extérieurs ou dans des environnements industriels humides ou polluants (libres de chlore)
 - Plastifiés en jaune: isolement élevé et grande résistance aux ambiances corrosives. On les utilise pour identifier les installations de gaz.
 - PVC: pour charges légères. Pose facile (peut se couper sans besoin d'outillage) et bonne résistance aux agents chimiques en général.

MATÉRIAU DU BASE



EXEMPLES D'APPLICATION





























Rails et console rails pour installations électriques, télécommunications et tuyauteries.

Supports pour chemin de câbles

Accessoires en complément des équipements basiques.

1. GAMME

ITEM	PHOTO	RÉFÉRENCE	DESCRIPTION	MATERIEL	REVÊTEMENT
1		GPZ201010	Rail 20 x 10 x 1	 Acier	 Zingué ≥ 5µm (\bar{x} = 7 µm)
		GPZ250808	Rail 25 x 8 x 0,80		
2		GPG271812 / GPG3M271812	Rail 27 x 18 x 1.25	 Acier	 Atlantis C2-M ≥ 7µm (\bar{x} = 10 µm)
		GPG283018 / GPG3M283018	Rail 28 x 30 x 1.80		
		GPG384020	Rail 38 x 40 x 2.00		
		GPG351312	Rail 35 x 12 x 1,20		
		GPG402015	Rail 40 x 20 x 1.50		
3		GPI271812	Rail 27 x 18 x 1.25	 Inoxydable A2	--
		GPI283015	Rail 28 x 30 x 1.50		
		GPI384020	Rail 38 x 40 x 2.00		
4		GPP271812	Rail 27 x 18 x 1.25	 Acier	 Peinture plastique jaune
5		GPV251120	Rail 25 x 11 x 2.00	 PVC	--
6		GPO357510	Rail Omega perforé/lisse zingué	 Acier	 Atlantis C2-M ≥ 7µm (\bar{x} = 10 µm)
		GPO351515			
		GLO357510			
		GLO351515			
7		SPZ271820	Console Rail 27 x 18 x 1,20 x 200	 Acier	 Zingué ≥ 5µm
		SPZ271830	Console Rail 27 x 18 x 1,20 x 300		
		SPZ384020	Console Rail 38 x 40 x 2,00 x 200		
		SPZ384025	Console Rail 38 x 40 x 2,00 x 250		
		SPZ384030	Console Rail 38 x 40 x 2,00 x 300		
		SPZ384035	Console Rail 38 x 40 x 2,00 x 350		
		SPZ384040	Console Rail 38 x 40 x 2,00 x 400		
		SPZ384050	Console Rail 38 x 40 x 2,00 x 500		
SPZ384060	Console Rail 38 x 40 x 2,00 x 600				
8		SPV2718	Support vertical	 Acier	 Zingué ≥ 5µm
		SPV3840			
9		SPH2718	Support horizontal	 Acier	 Zingué ≥ 5µm
		SPH3840			
10		SPGH2718	Support horizontal pour rails	 Acier	 Zingué ≥ 5µm
		SPGH3840			

2. TABLEAU DE COMPATIBILITÉ.

			LES SOUTIENS						SUPPORTS ET CONNEXIONS				PONTS GUIDES				VIS DE GUIDAGE						ÉCROUS DE GUIDAGE				FICHES																													
Code	Mesure (mm)	Longueur (mm)	Verticale M10	Verticale M10	Horizontal M10	Horizontal M10	Horizontal	Horizontal	45°	90°	Plana	45° Inoxydable	90° Inoxydable	Plate Inoxydable	GZ2718	PGZ2830	PGZ3840	PGI2718	PGI2830	PGI3840	TG230620	TG230820	TG230830	TG340830	TG341030	TGR230620	TGR230820	TGR230830	TGR340830	TGR341030	TUG201006	TUG201008	TUG271808	TUG271810	TUGRA2706	TUGRA2708	TUGRA3808	TUGRA3810	SOTP2718	SOTP2830	SOTP3840	SOTP4121														
GUIDES PERFORÉS	GPZ201010	20X10X1	2000																																																					
	GPZ250808	25X8X0,8	1000																																																					
	GPG271812/ GPG3M271812	27x18x1,25	2000/3000	•	•	•			•	•	•			•																																										
	GPG283018/ GPG3M271812	28x30x1,8	2000/3000	•	•	•			•	•	•			•																																										
	GPG351312	35x13x1,2	2000						•	•	•																																													
	GPG384020	38x40x2	2000	•	•	•	•	•	•	•	•							•							•	•																														
	GPG402015	40x40x1,5	2000	•	•	•	•	•	•	•	•																																													
	GPI271812	27x18x1,25	2000																																																					
	GPI283015	28x30x1,8	2000																																																					
	GPI384020	38x40x2	2000																																																					
	GPP271812	27x18x1,25	1000	•	•				•	•	•				•																																									
	GPV251120	25x11x2	1000						•	•	•																																													
	GLO357510	35x7,5x1	2000																																																					
	GLO351515	35x15x1,5	2000																																																					
	GPO357510	35x7,5x1	2000																																																					
GPO351515	35x15x1,5	2000																																																						
LES SOUTIENS	SPZ271820	27x18x1,25	200																																																					
	SPZ271830	27x18x1,25	300																																																					
	SPZ384020	38x40x2	200																																																					
	SPZ384025	38x40x2	250																																																					
	SPZ384030	38x40x2	300																																																					
	SPZ384035	38x40x2	350																																																					
	SPZ384040	38x40x2	400																																																					
	SPZ384050	38x40x2	500																																																					
	SPZ384060	38x40x2	600																																																					

3. DATOS DE INSTALACION

3.1 GP-Z

Rail perforé zingué



Matériel



Acier

Revêtement



Zingué $\geq 5\mu\text{m}$ ($\bar{x} = 7\mu\text{m}$)

Données d'installation

Code	A1	A2	B	C	$\varnothing D$	E	F	G	L
GPZ201010	20	10	1,0	10,5	6,5	5	15	25	2000
GPZ250808	25	8	0,8	14,0	6,5	3,5	18	25	1000

Plan

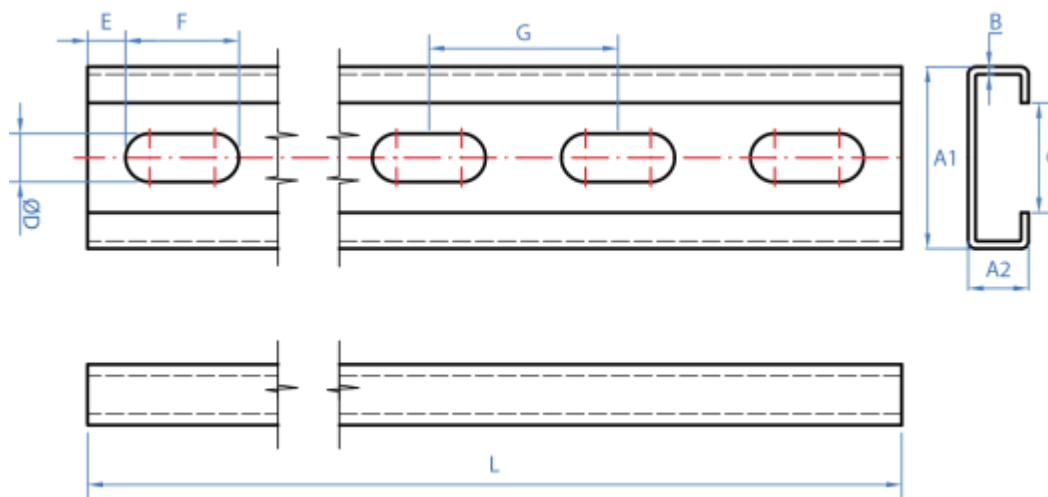

3.2 GP-G

Rail perforé galvanisé



Matériel



Acier

Revêtement



Atlantis C2 H
 ≥ 7µm (\bar{x} = 10 µm) GPG271812
 ≥ 15µm (\bar{x} = 20 µm) Reste des profilés

Données d'installation

Code	A1	A2	B	C	ØD1	ØD2	E	F	G	H	L1
GPG271812	27	18	1,25	15,0	10,5	8,5	8,0	18,5	30	30	2000
GPG3M271812	27	18	1,25	15,0	10,5	8,5	8,0	18,5	30	30	3000
GPG283018	28	30	1,80	15,0	12,0	10,0	7,5	20,0	35	35	2000
GPG3M283018	28	30	1,80	15,0	12,0	10,0	7,5	20,0	35	35	3000
GPG384020	38	40	2,00	17,0	12,0	10,0	7,5	20,0	35	35	2000
GPG351312	35	13	1,20	15,5	8,5	--	4,0	18,0	28,0	--	2000
GPG402015	40	20	1,50	23,5	12,0	--	7,0	36,0	50	--	2000

Plan

GPG271812 / GPG283018 / GPG384020

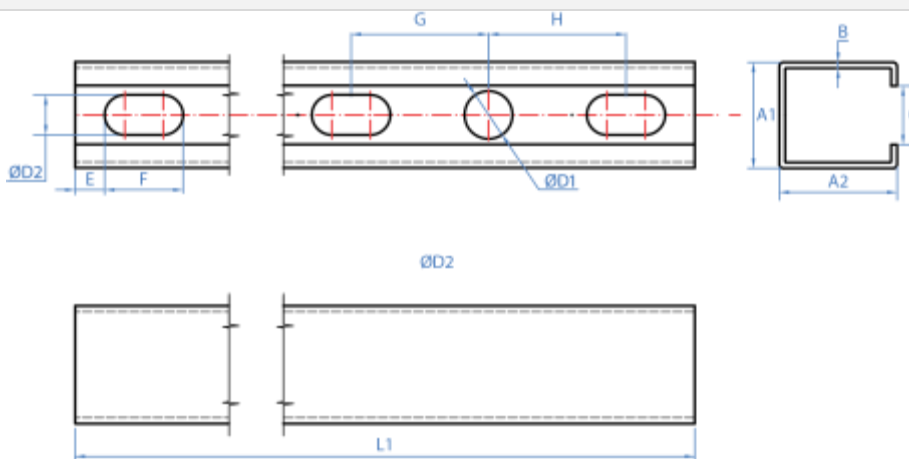

GPG351312 / GPG402015

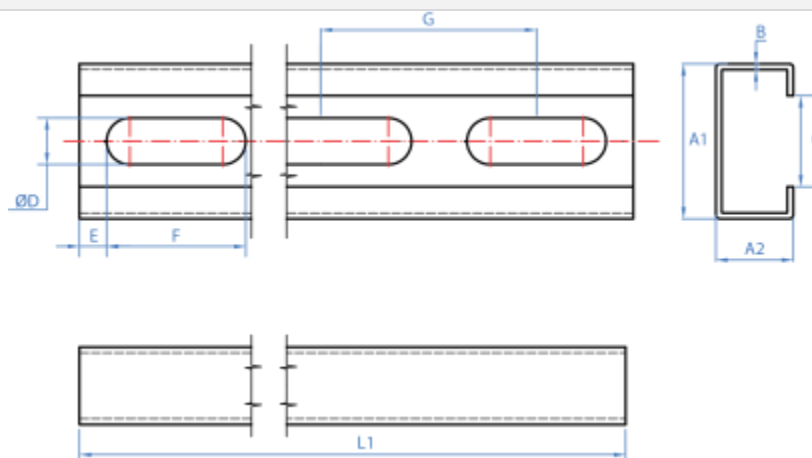

3.3 GP-A2

Rail perforé inoxydable



Matériel



Acier

Revêtement



Inoxydable A2

Données d'installation

Code	A1	A2	B	C	ØD1	ØD2	E	F	G	H	L1
GPI271812	27	18	1,25	15,0	12,0	8,0	15	20	35	35	2000
GPI283015	28	30	1,50	15,0	12,0	10,0	10	20	35	35	2000
GPI384020	38	40	2,00	17,0	12,0	12,0	9,5	20	35	35	2000

Plan

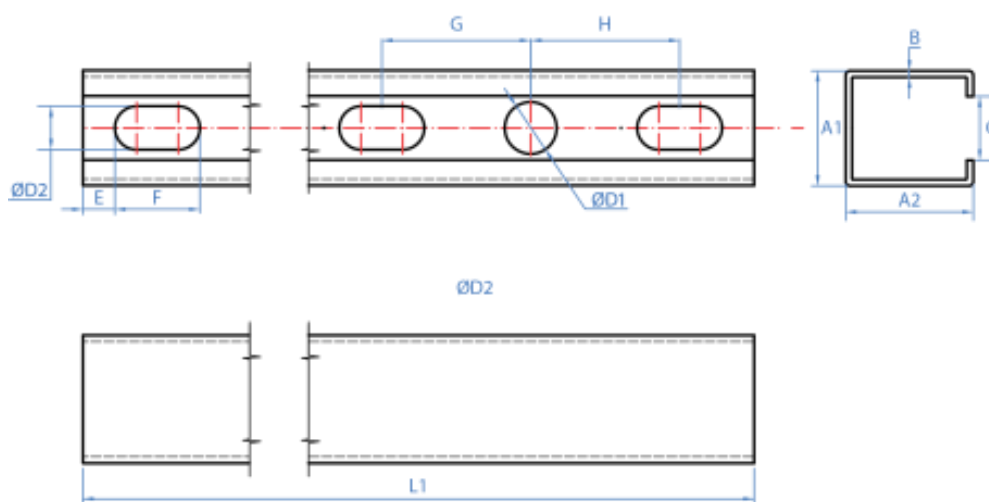

3.4 GP-PL

Rail perforé plastique



Matériel



Acier

Revêtement



Peinture plastique jaune

Données d'installation

Code	A1	A2	B	C	ØD1	ØD2	E	F	G	H	L1
GPP271812	27	18	1,25	15,0	12,0	8,0	15	20	35	35	1000

Plan

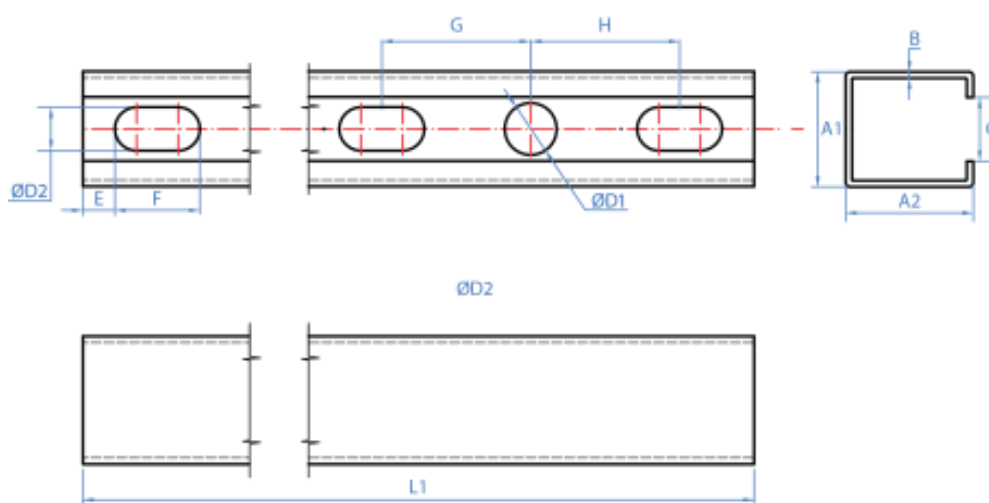

3.5 GP-PVC

Rail perforé PVC



Matériel



PVC

Données d'installation

Code	A1	A2	B	C	ØD1	ØD2	E	F	G	L1
GPV251120	25	11,5	2,0	11,5	6,0	6,0	14	13	13	1000

Plan

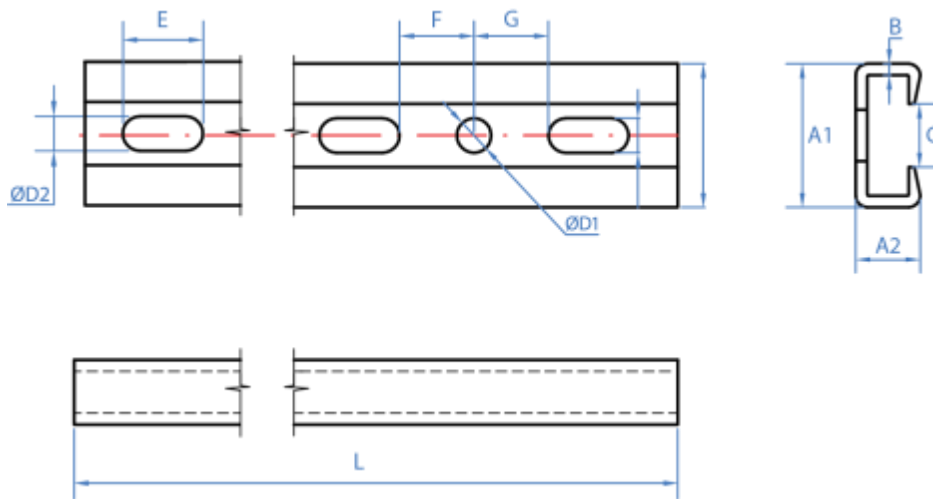

3.6 GP-O / GL-O

Rail Omega perforé/ lisse zingué



Matériel	Revêtement
Acier	Atlantis C2-M $\geq 7\mu\text{m}$ ($\bar{x} = 10\mu\text{m}$)

Données d'installation

Code	A1	A2	B	C	$\varnothing D2$	E	F	G	L1
GPO357510	27	7,5	1,0	35	6,25	10	12	10	2000
GPO351515	27	15	1,5	35	6,25	10	12	10	2000
GLO357510	27	7,5	1,0	35	--	10	12	10	2000
GLO351515	27	15	1,5	35	--	10	12	10	2000

Plan

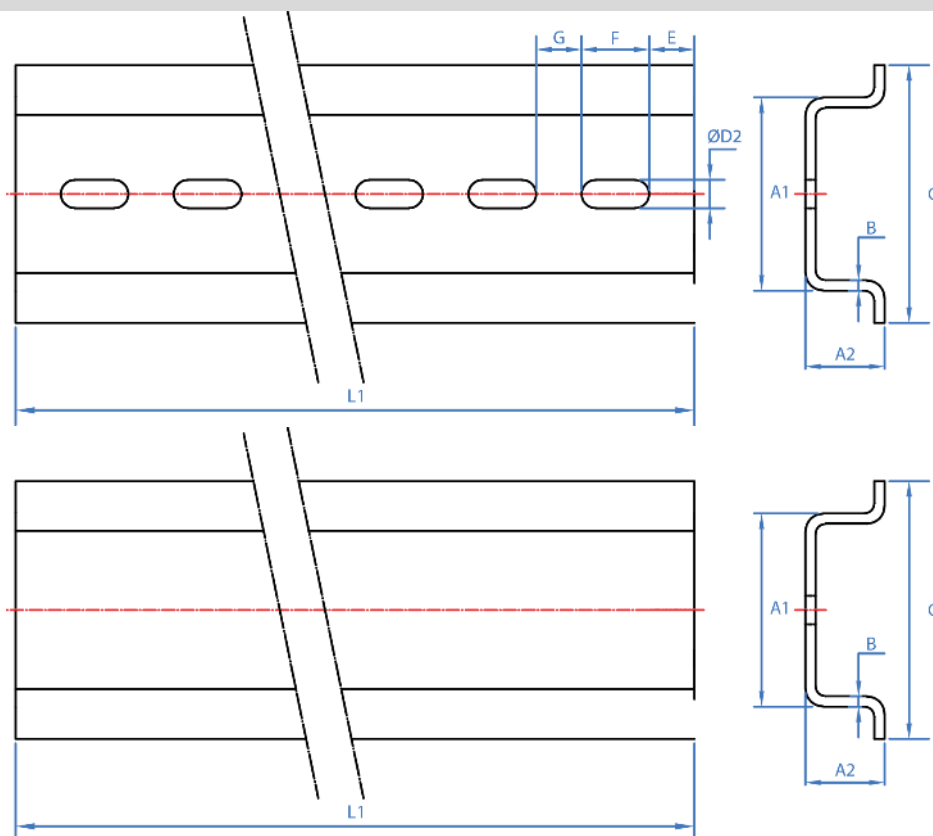

3.7 SP-Z

Console rail perforé pour rails perforés



Matériel	Revêtement
Acier	Zingué

Données d'installation

Code	A1	A2	B1	B2	C	ØD1	ØD2	Ød1	Ød2	E	F	G	H1	H2	L1	L2	L3
SPZ271820	27	18	1,25		40		8			15	10				200	80	120
SPZ271830															300		
SPZ384020	38	40	2,00	4,5	45	12	12	11	8	17		35	20	18	200	90	132
SPZ384025															250		
SPZ384030															300		
SPZ384035															350		
SPZ384040															400		
SPZ384050															500		
SPZ384060	600																

Plan

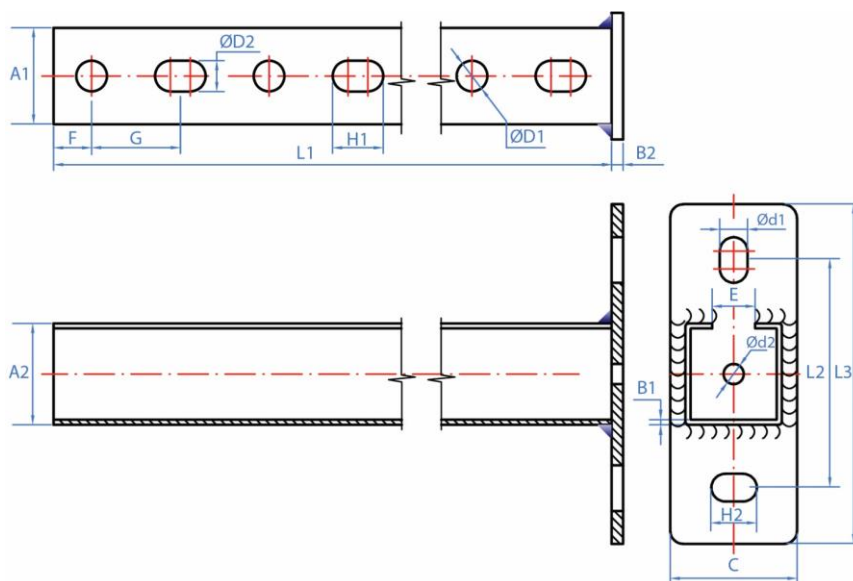

3.8 SP-V

Support vertical



Matériel	Revêtement	Valable pour
A	Z ZINC	
Acier	Zingué	Rails perforés GP-G

Données d'installation

Code	A	B1	B2	C	ØD	E	F	G	L1	L2	M
SPV2718	21,5	4	10	42,5	11	15	40	20	120	88	10
SPV3840	30										

Plan

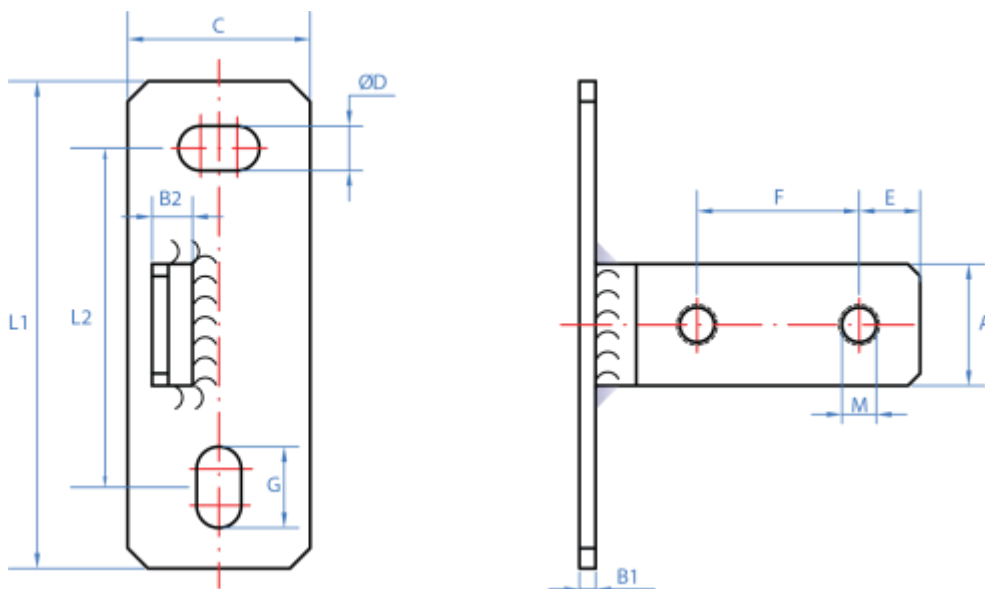

3.9 SP-H

Support horizontal



Matériel	Revêtement	Valable pour
A	Z ZINC	
Acier	Zingué	Rails perforés GP-G

Données d'installation

Code	A	B1	B2	C	ØD	E	F	G	L1	L2	M
SPH2718	21,5	4	10	42,5	11	15	40	20	120	80	10
SPH3840	30										

Plan

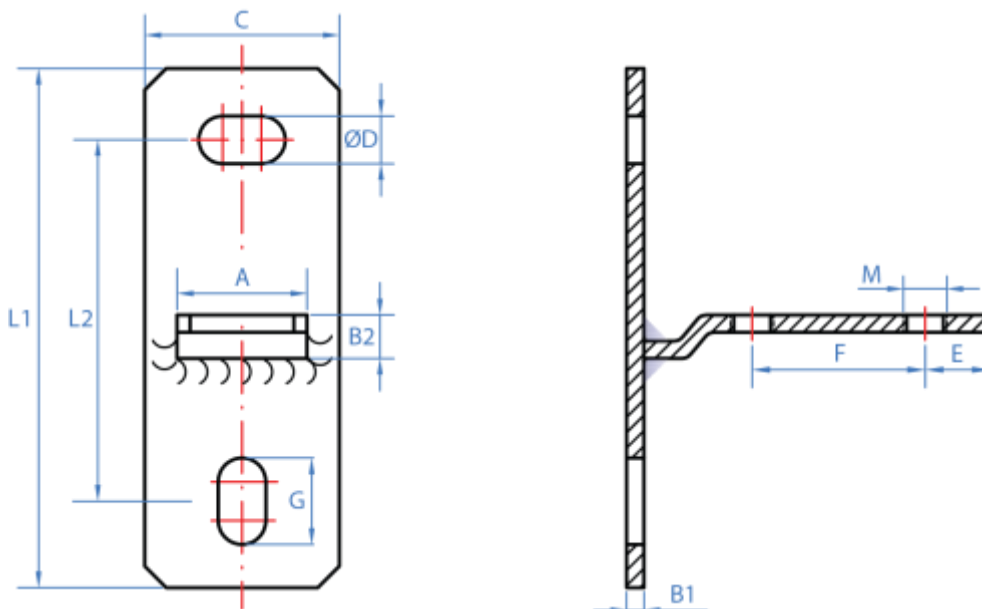

3.10 SP-HX

Support horizontal pour rails perforés



Matériel	Revêtement	Valable pour
Acier	Zingué	Rails perforés GP-G

Données d'installation

Code	A1	A2	B1	B2	C	ØD	Ød	E	G1	G2	L1	L2	L3
SPGH2718	31	20	3	4	40	11,0	11	11	19	19	70	78	120
SPGH3840	42	35	4	6	60	13,5	11	12	25	16	90	103	145

Plan

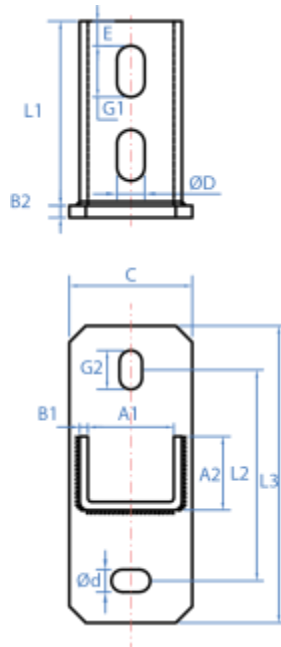

4. DONNÉES GÉOMÉTRIQUES

REFERENCE	SECTION	POIDS	AIRE	MOMENT D'INERTIE I _y	MOMENT D'INERTIE I _z	MODULE DE RÉSISTANCE (W _y)	MODULE DE RÉSISTANCE (W _z)	
	[mm x mm]	[Kg/m]	[cm ²]	[cm ⁴]	[cm ⁴]	[cm ³]	[cm ³]	
GPZ201010	20 x 10	0.31	0.44	0.06	0.25	0.10	0.25	
GPZ250808	25 x 8	0.26	0.35	0.03	0.30	0.06	0.24	
GPG271812	27 x 18	0.66	0.84	0.37	0.97	0.34	0.71	
GPG283018	28 x 30	1.25	1.60	1.79	2.10	1.03	1.50	
GPG384020	38 x 40	2.00	2.55	5.39	6.18	2.39	3.25	
GPG351312	35 x 13	Prestation non déclaré						
GPG402015	40 x 20	0.94	1.30	0.71	3.10	0.57	1.55	
GPP271812	27 x 18	0.66	0.84	0.37	0.97	0.34	0.71	
GPI271812	27 x 18	0.66	0.79	0.36	0.90	0.33	0.67	
GPI283015	28 x 30	1.25	1.37	1.54	1.82	0.89	1.30	
GPI384020	37 x 40	2.00	2.55	5.39	6.18	2.39	3.25	
SPZ271820	27 x 18	1,20	0.84	0.37	0.97	0.34	0.71	
SPZ271830	27 x 18	1,20	0.84	0.37	0.97	0.34	0.71	
SPZ384020	38 x 40	2,4	2.55	5.39	6.18	2.39	3.25	
SPZ384025	38 x 40	2,4	2.55	5.39	6.18	2.39	3.25	
SPZ384030	38 x 40	2,4	2.55	5.39	6.18	2.39	3.25	
SPZ384035	38 x 40	2,4	2.55	5.39	6.18	2.39	3.25	
SPZ384040	38 x 40	2,4	2.55	5.39	6.18	2.39	3.25	
SPZ384050	38 x 40	2,4	2.55	5.39	6.18	2.39	3.25	
SPZ384060	38 x 40	2,4	2.55	5.39	6.18	2.39	3.25	

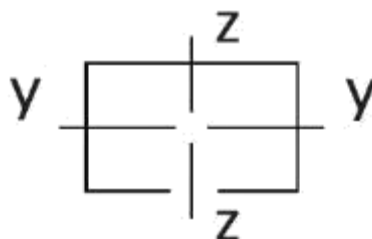

5. HYPOTHÈSES DE CALCUL ET CHARGES

HYPOTHÈSES DE CALCUL POUR RAILS GP-Z

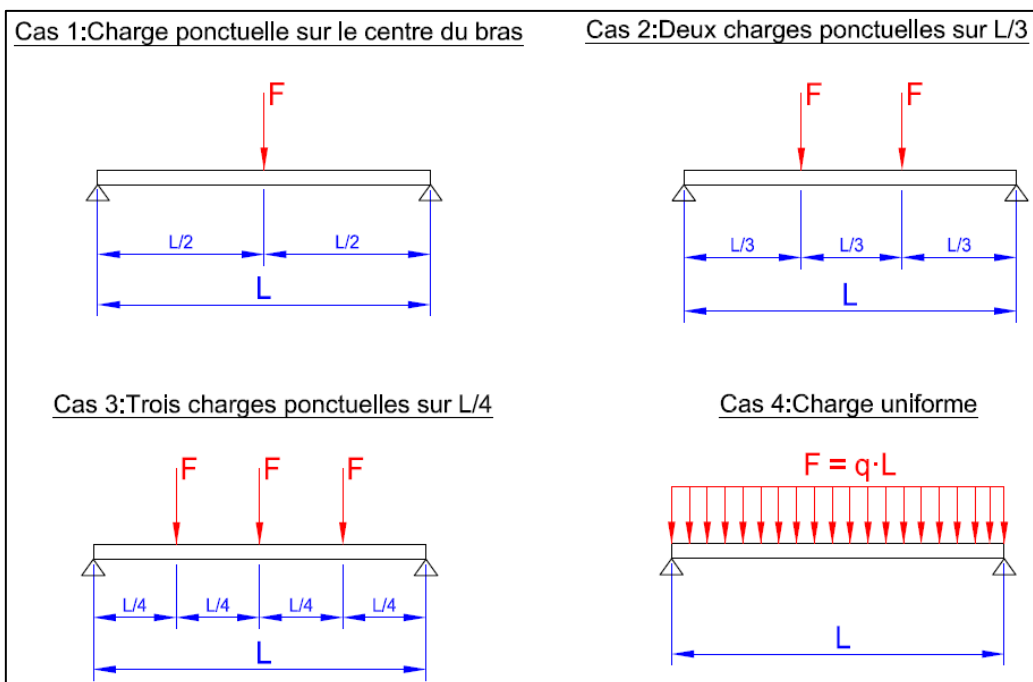

HYPOTHÈSES DE CALCUL POUR CONSOLE RAILS SP-Z

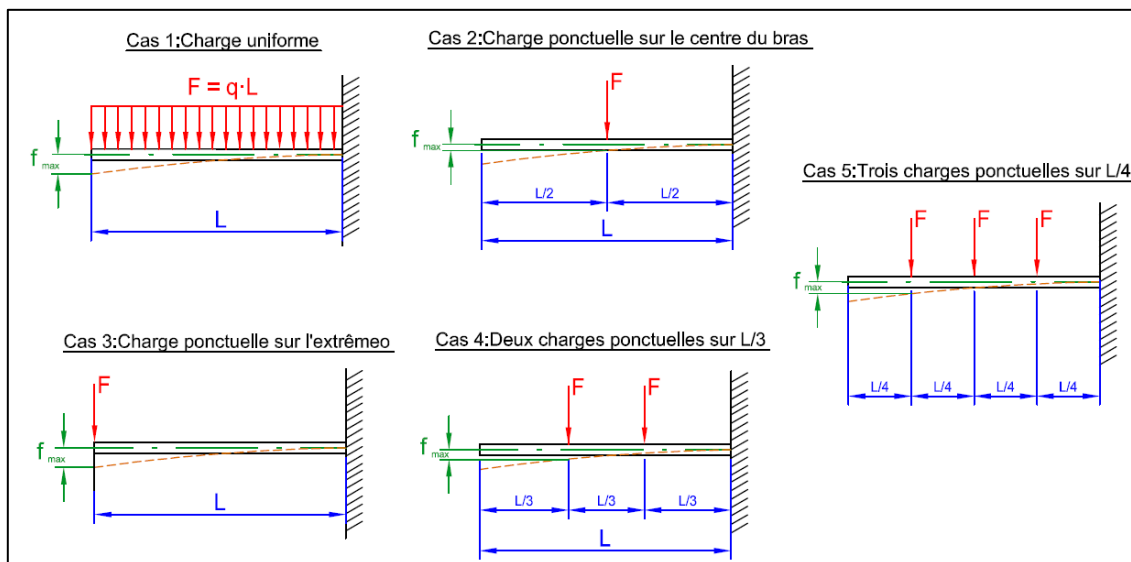

CHARGES MAXIMALES RECOMANDEE POUR RAILS PERFORE GP-Z

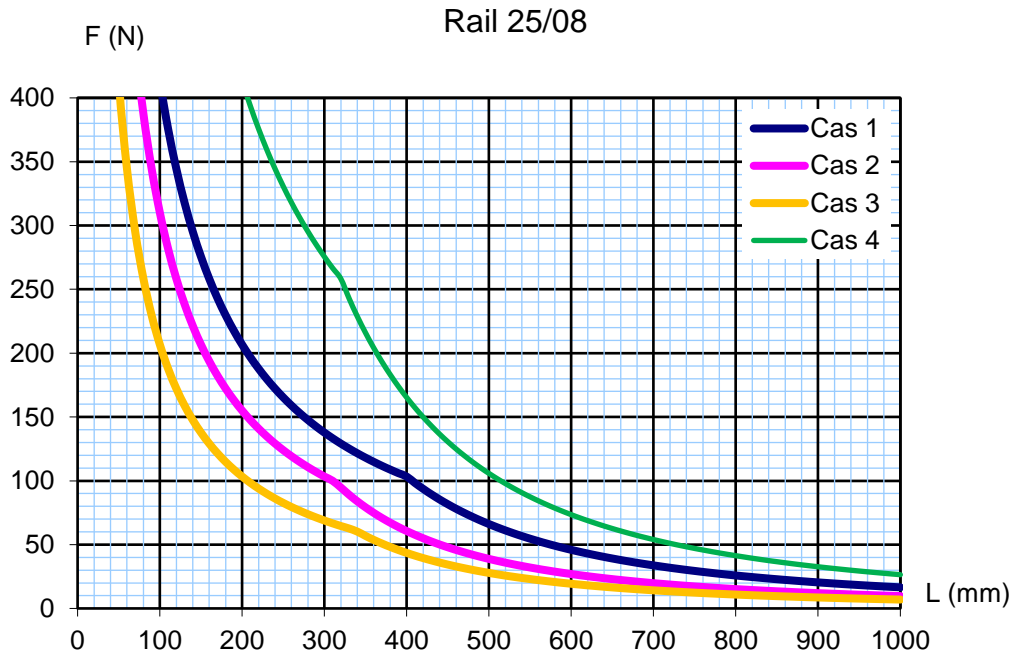
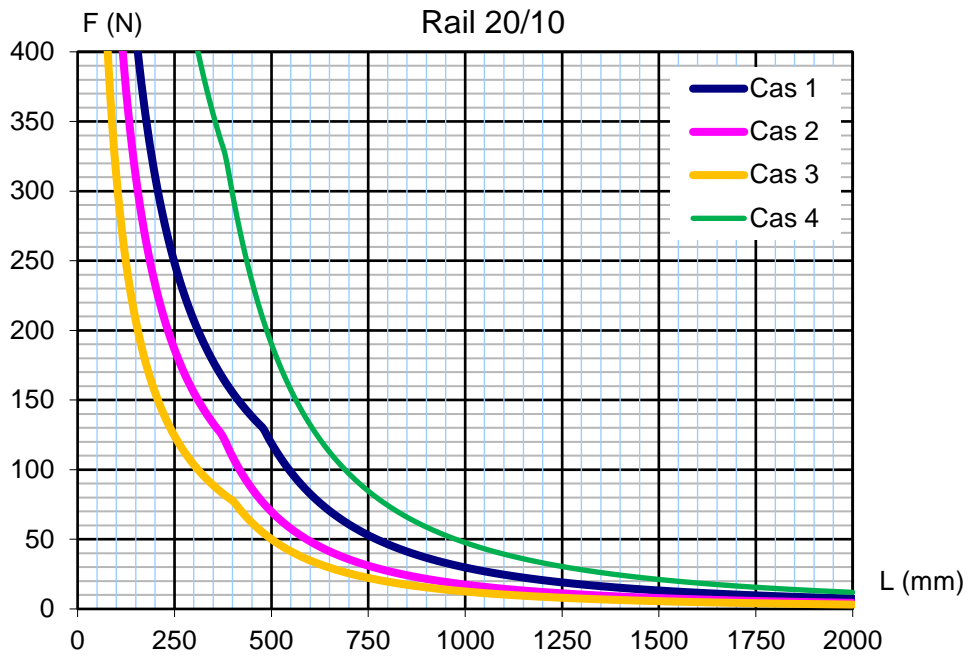

CHARGES MAXIMALES RECOMANDEE POUR RAILS PERFORE GP-G

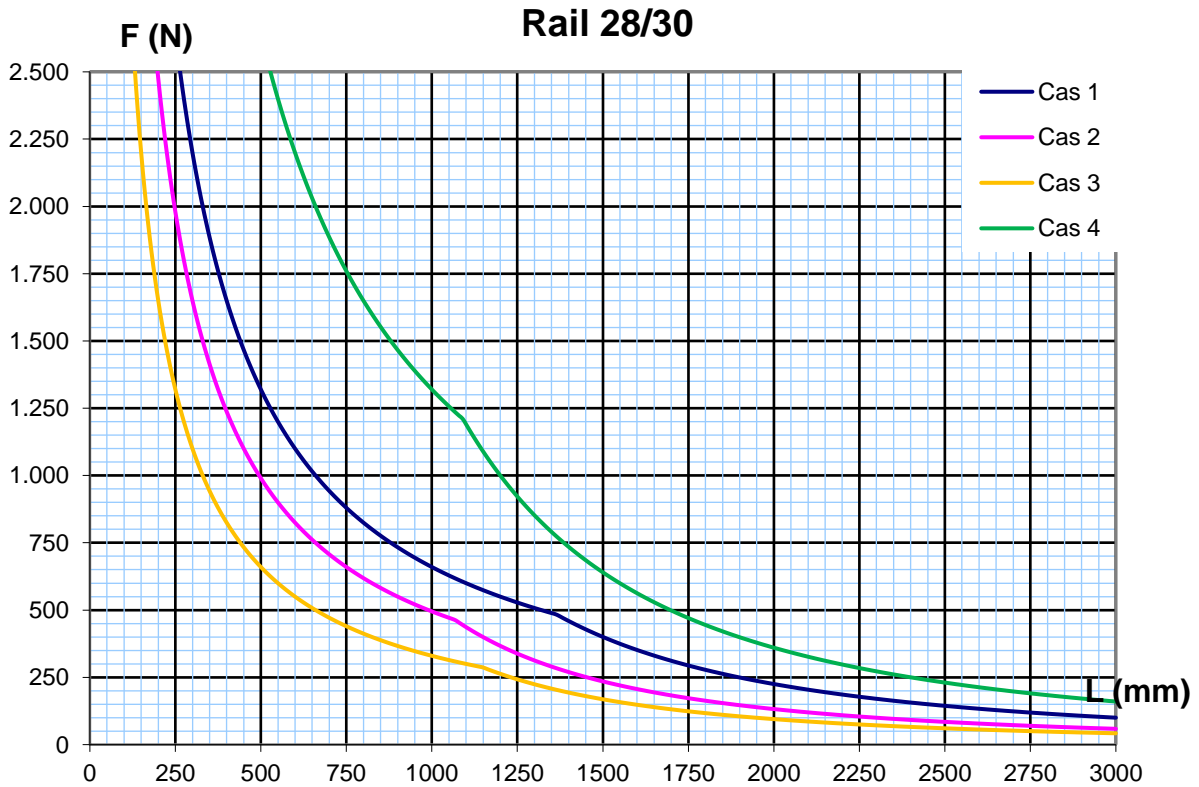
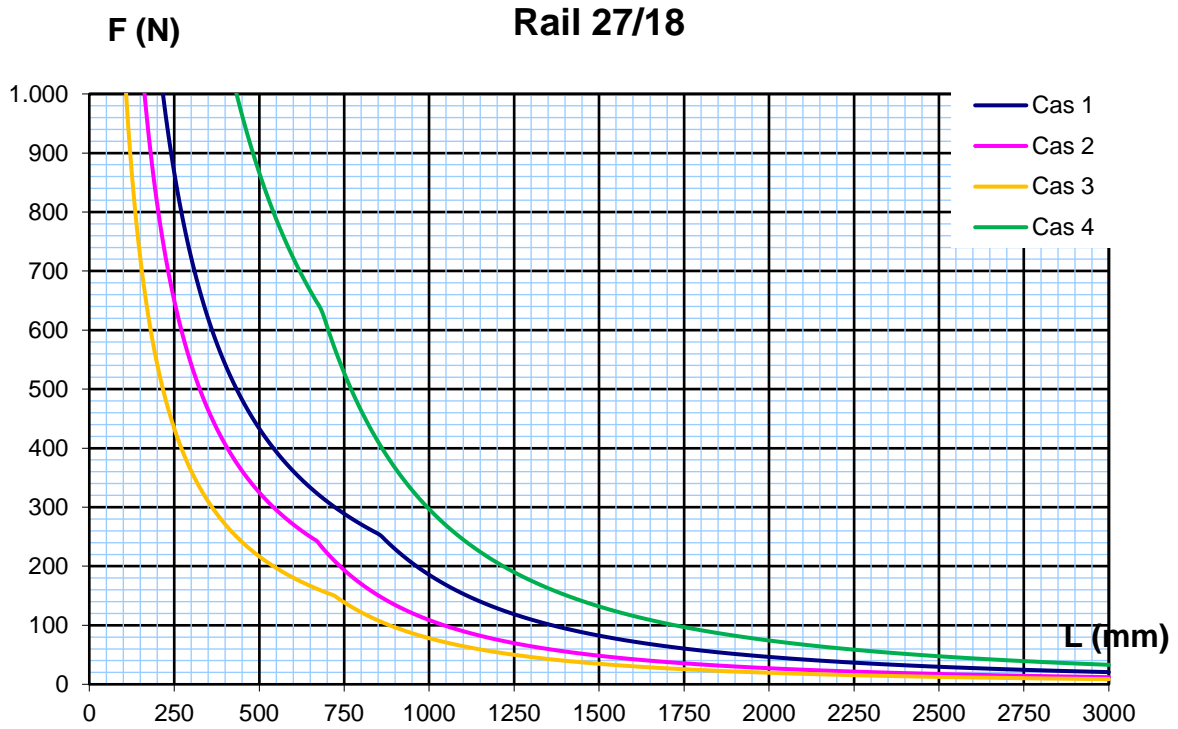

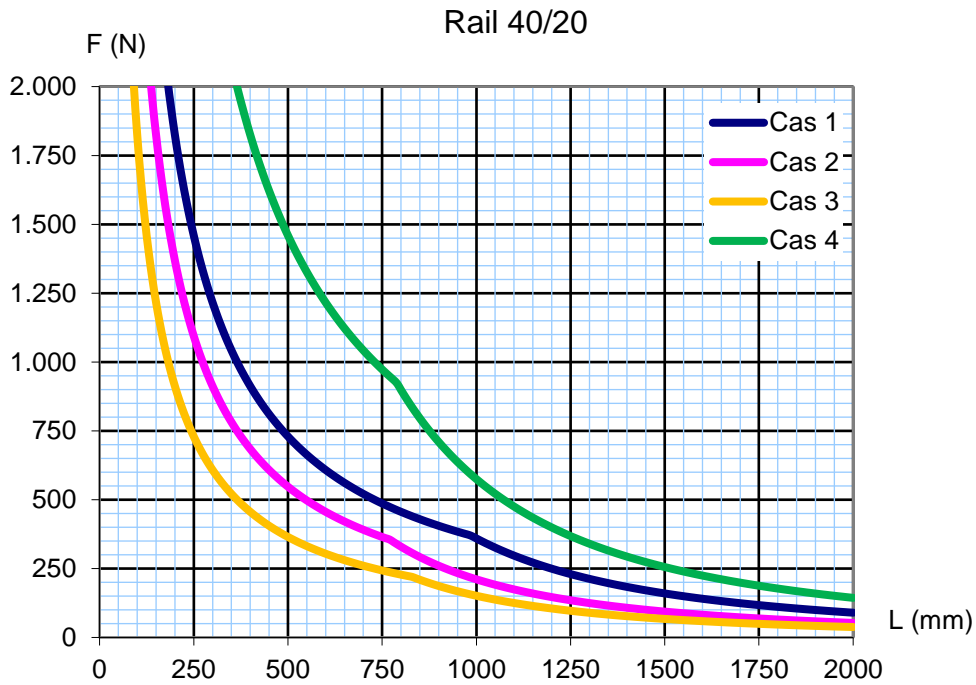
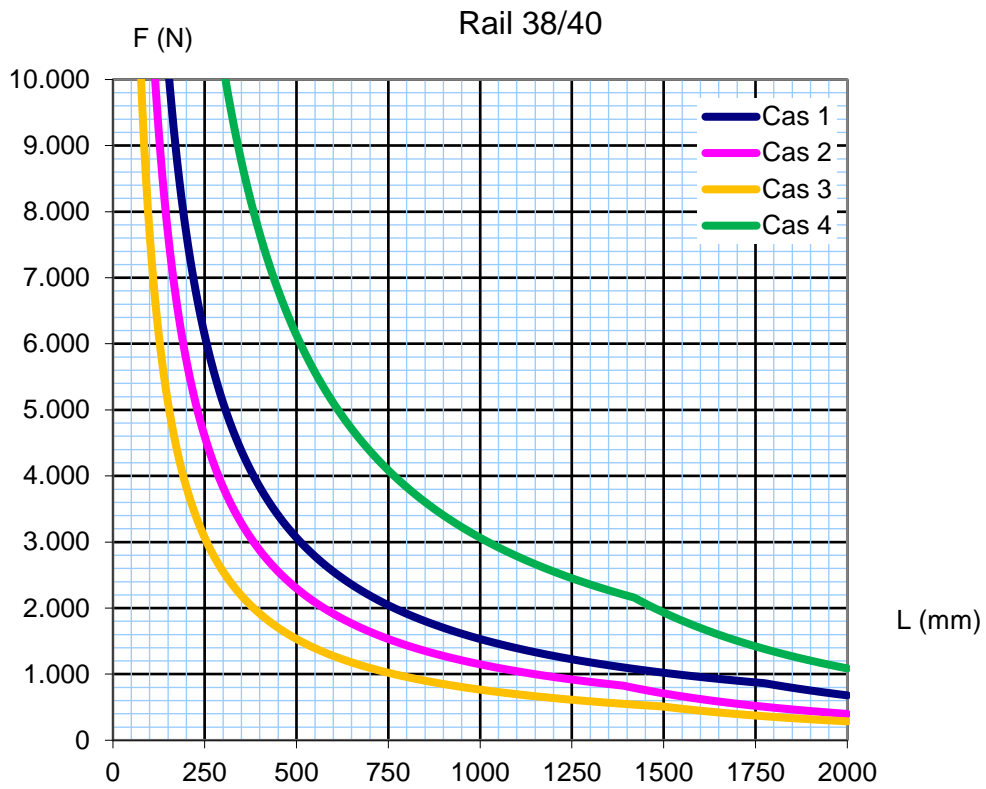

CHARGES MAXIMALES RECOMANDEE POUR RAILS PERFORE GP-A2

Rail INOX 27/18

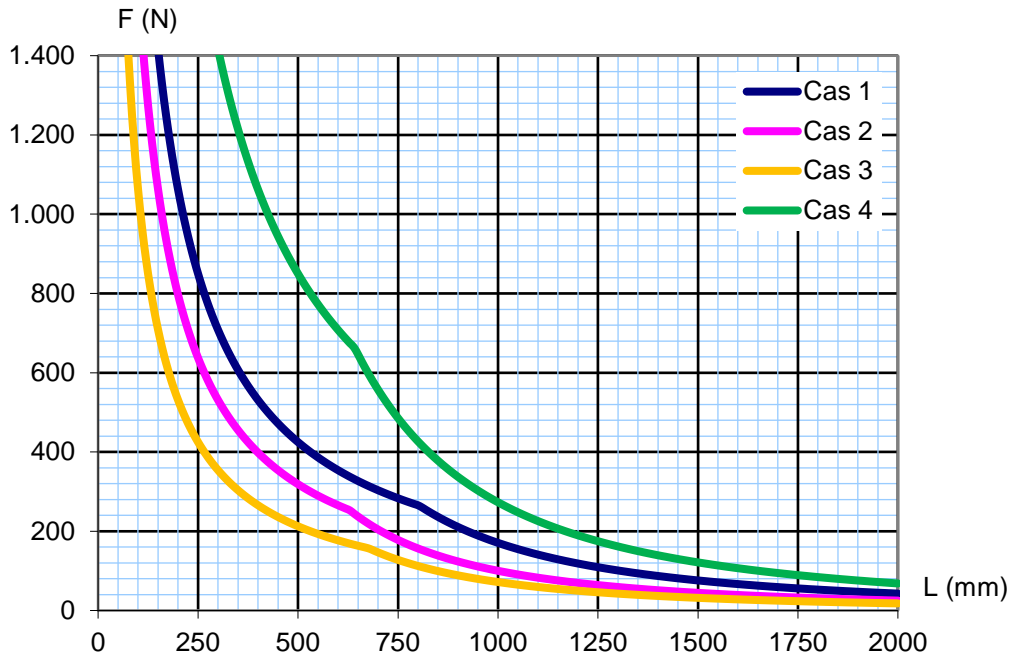

Rail INOX 28/30

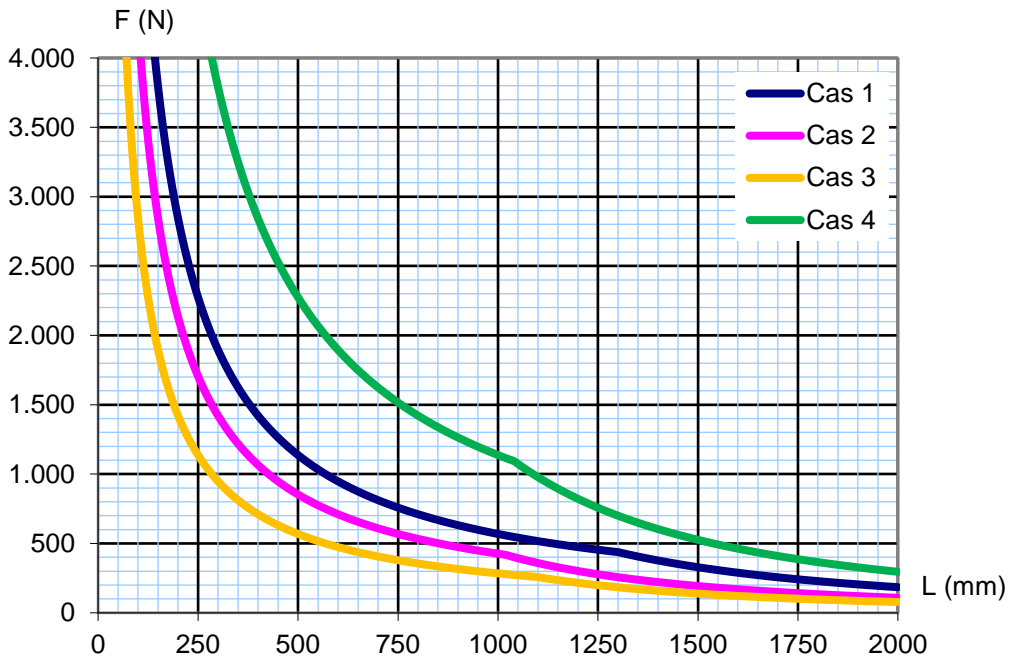

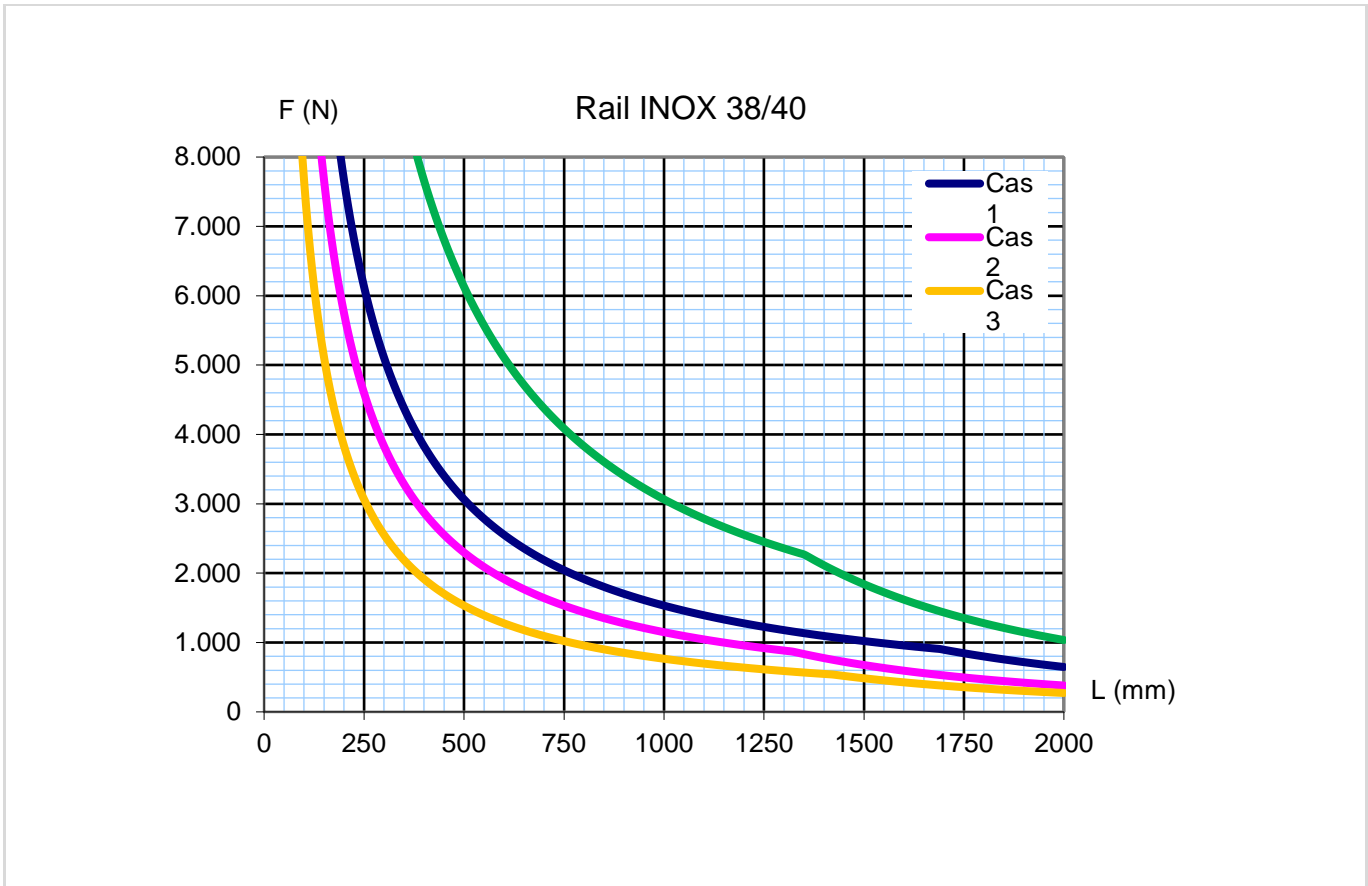

CHARGES MAXIMALES RECOMANDEE POUR CONSOLE RAILS PERFORE SP-Z

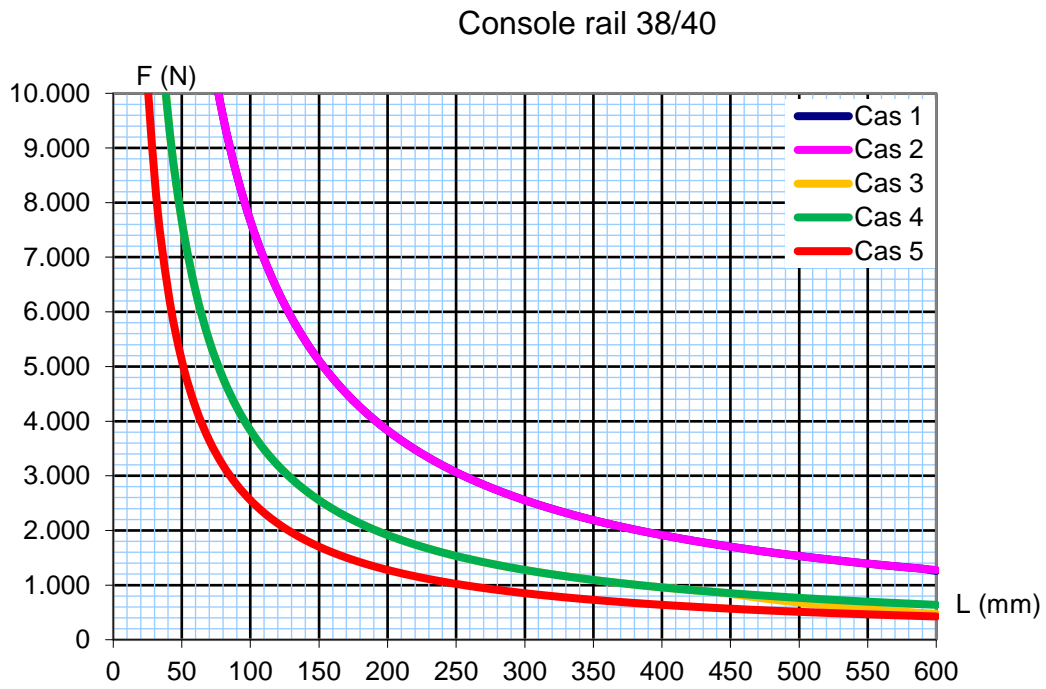
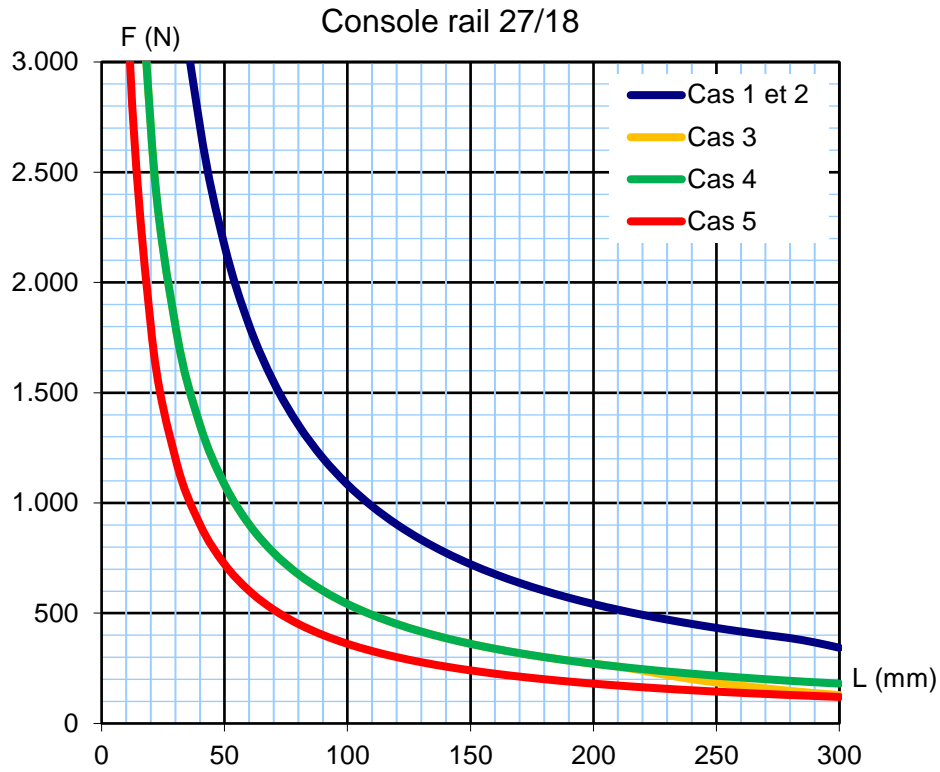

EXEMPLE DE CALCUL POUR RAIL PERFORE

Exemple de calcul rail perforé:

Rail GPG402015: Longueur de rail 800 mm avec trois colliers équidistants situés à 200 mm (cas N° 3).

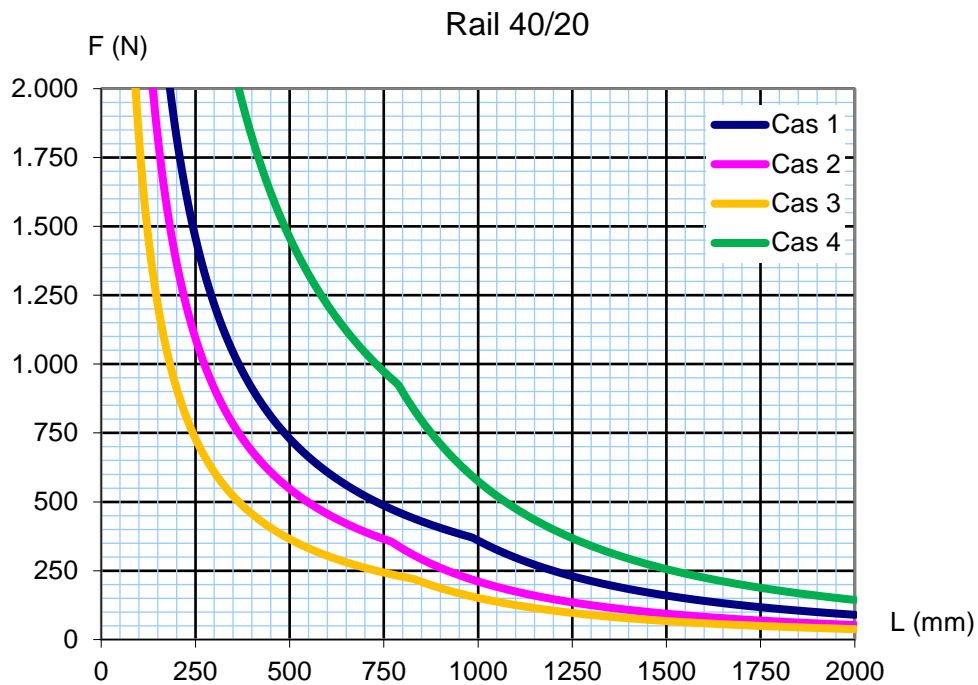
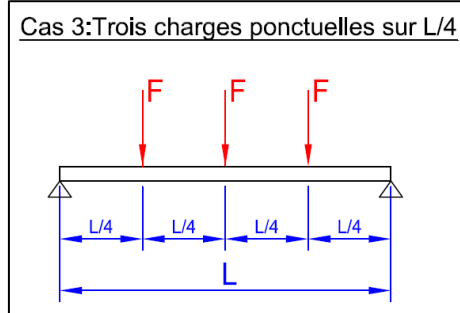

Il en résulte une charge admissible par collier de 250 N (≈25 Kg).

EXEMPLE DE CALCUL POUR CONSOLE RAIL

Exemple de calcul console rail perforé:

Console rail SPZ384020: Un seul tuyau situé à 150 mm de la paroi (cas N°2).

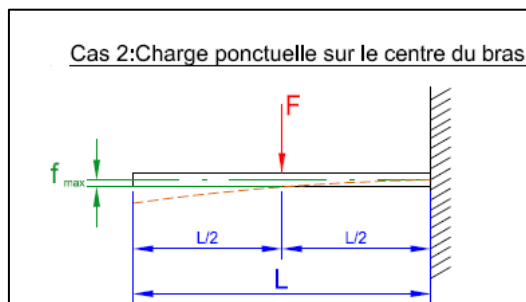

Console rail 38/40

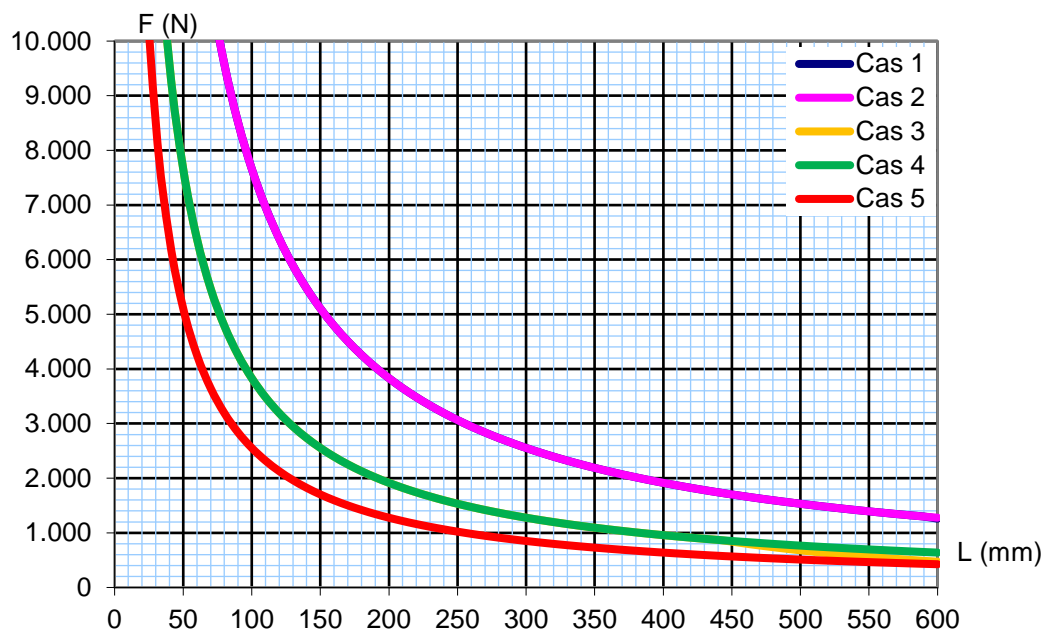

Il en résulte une charge admissible de 5.000 N (≈500 Kg).

Ces charges admissibles ne peuvent s'appliquer que si les Console rails sont fixés avec des ancrages qui remplissent les conditions d'emploi et d'application de ceux-ci.

Par ailleurs, on doit vérifier que les forces se transmettent au matériau de base (acier ou béton)

Chevilles recommandées : AH08075, AH10090, MIA408075, MIA410090, HEHOM08 y HEHOM10