



CARACTERISTIQUES

Élément de fixation mécanique de fonctionnement par déformation pour l'union de deux éléments.

Particulièrement utile lorsque les deux éléments à fixer ont uniquement un accès par un côté.

Union rapide et simple.

Pour application avec riveteuses manuelles, de batterie ou pneumatique.

Versions acier-aluminium et inoxydable.

MATÉRIAU DE BASE



Menuiserie aluminium



Assemblage Tôle











Tôle – profilé lourd

EXEMPLES D'APPLICATION



Exemples: Joints entre plaques de métal, cadres en aluminium et tôle

1. RANGE				
ITEM	CODE	DIMENSIONS	PHOTO	COMPOSANT
1	RE-NO	De 3,2 x 6 mm à 6 x 25 mm		Rivet standard
2	RE-BL / RE-NL	De 3,2 x 8 mm à 4,8 x 16 mm		Blanc / Noir rivet
3	RE-CA	De 4 x 8 mm à 4,8 x 18 mm		Rivet à tête large
4	RE-FL	De 4 x 12 mm à 4,8 x 50 mm		Peel dome tête rivet
5	RE-IN	De 3,2 x 6,4 mm à 4,8 x 20 mm		Rivet en acier inoxydable
6	RM-MA	--		Outil à main pour rivets aveugles
7	RM-PA	--		Rivet à bras long
8	RM-EX	--		Tondeuse à paupières

2. DONNÉES D'INSTALLATION

2.1. RE-NO

Rivet Standard



Propriétés



Corps en aluminium



Zingué axe

Dimensions

CODE	Ø Foret [mm]	Epaisseur de fixation [mm]	Ø d1 [mm]	L [mm]	Ø d2 [mm]	K [mm]	W [mm]
RENO3206	3,3	1,0 – 3,0	3,2	06	6,2	1,2	1,8
RENO3208		3,0 – 5,0		08			
RENO3210		5,0 – 7,0		10			
RENO3212		7,0 – 9,0		12			
RENO3214		9,0 – 11,0		14			
RENO3216		11,0 – 13,0		16			
RENO3218		13,0 – 15,0		18			
RENO4006	4,1	0,5 – 2,0	4,0	06	7,5	1,5	2,2
RENO4008		2,0 – 4,0		08			
RENO4010		4,0 – 6,0		10			
RENO4012		6,0 – 8,0		12			
RENO4014		8,0 – 10,0		14			
RENO4016		10,0 – 12,0		16			
RENO4018		12,0 – 14,0		18			
RENO4020		14,0 – 16,0		20			
RENO4025		16,0 – 18,0		25			
RENO4030		23,0 – 16,0		30			
RENO4035		26,0 – 30,0		35			
RENO4806	5,0	0,5 – 1,5	4,8	06	9,0	1,6	2,7
RENO4808		1,5 – 3,5		08			
RENO4810		3,5 – 5,5		10			
RENO4812		5,5 – 7,5		12			
RENO4814		7,5 – 9,5		14			
RENO4816		9,5 – 11,5		16			
RENO4818		11,5 – 13,5		18			
RENO4820		13,5 – 15,0		20			
RENO4822		15,0 – 17,0		22			
RENO4824		17,0 – 19,0		24			
RENO4826		19,0 – 21,0		26			
RENO4828		21,0 – 23,0		28			
RENO4830		23,0 – 25,0		30			
RENO4835		25,0 – 30,0		35			
RENO6008	6,1	1,0 – 2,0	6,0	08	11,3	1,9	3,2
RENO6010		2,0 – 4,0		10			
RENO6012		3,0 – 6,0		12			
RENO6016		6,0 – 10,0		16			
RENO6018		10,0 – 12,0		18			
RENO6025		15,0 – 19,0		25			

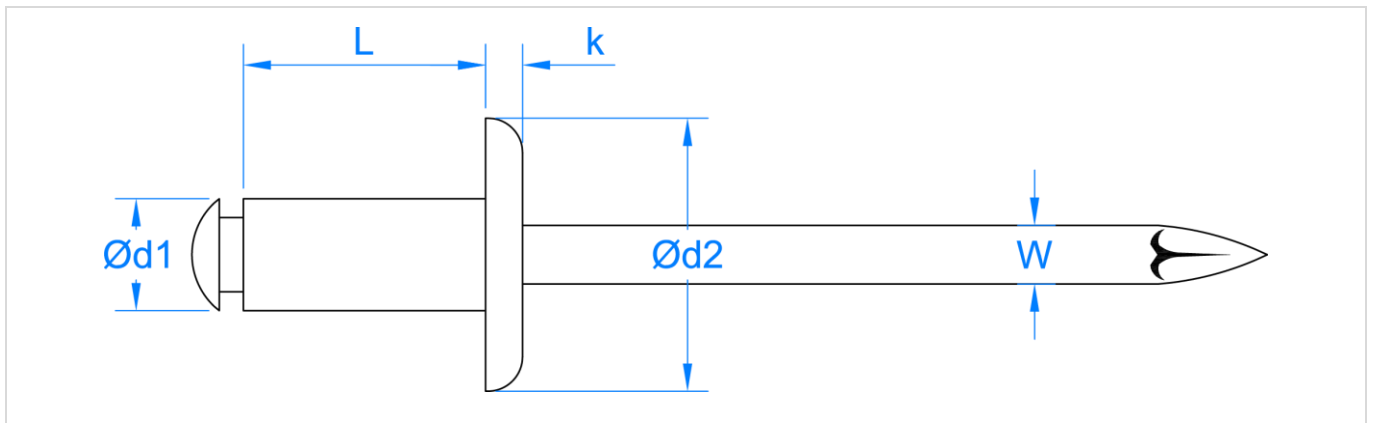

2.2. RE-BL/RE-NE Blanc rivet / Noir rivet



Propriétés



Corps en aluminium



Zingué axe

Dimensions

CODE	Ø Foret [mm]	Epaisseur de fixation [mm]	Ø d1 [mm]	L [mm]	Ø d2 [mm]	K [mm]	W [mm]
RENO3208BL / NE	3,3	3,5 – 5,0	3,2	08	6,3	1,0	1,8
RENO3210BL / NE		5,0 – 7,0		10			
RENO3212BL / NE		7,0 – 9,0		12			
RENO4008BL / NE	4,1	3,0 – 5,0	4,0	08	8,0	1,3	2,2
RENO4010BL / NE		5,0 – 6,5		10			
RENO4012BL / NE		6,5 – 8,5		12			
RENO4014BL / NE		8,5 – 10,5		14			
RENO4810BL / NE	5,0	4,0 – 6,0	4,8	10	9,5	1,4	2,6
RENO4812BL / NE		6,0 – 8,0		12			
RENO4814BL / NE		8,0 – 10,0		14			
RENO4816BL / NE		10,0 – 12,0		16			

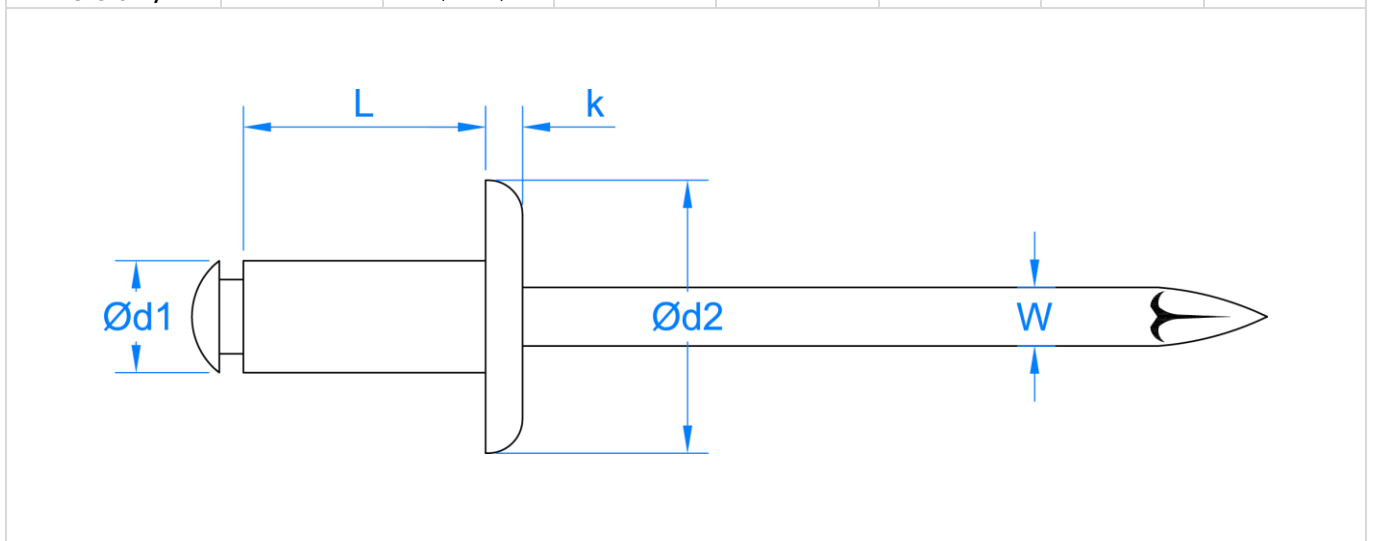

2.3. RE-CA

Rivet à tête large



Propriétés



Corps en aluminium



Zingué axe

Dimensiones

CODE	Ø Foret [mm]	Epaisseur de fixation [mm]	Ø d1 [mm]	L [mm]	Ø d2 [mm]	K [mm]	W [mm]
RECA4008	4,1	2,0 – 4,0	4	08	11,8	1,9	2,2
RECA4010		4,0 – 6,0		10			
RECA4012		6,0 – 8,0		12			
RECA4016		10,0 – 12,0		16			
RECA4810	5,0	3,5 – 5,5	4,8	10	13,8	2,3	2,6
RECA4812		5,5 – 7,5		12			
RECA4814		7,5 – 9,5		14			
RECA4816		9,5 – 11,5		16			
RECA4818		11,5 – 13,5		18			

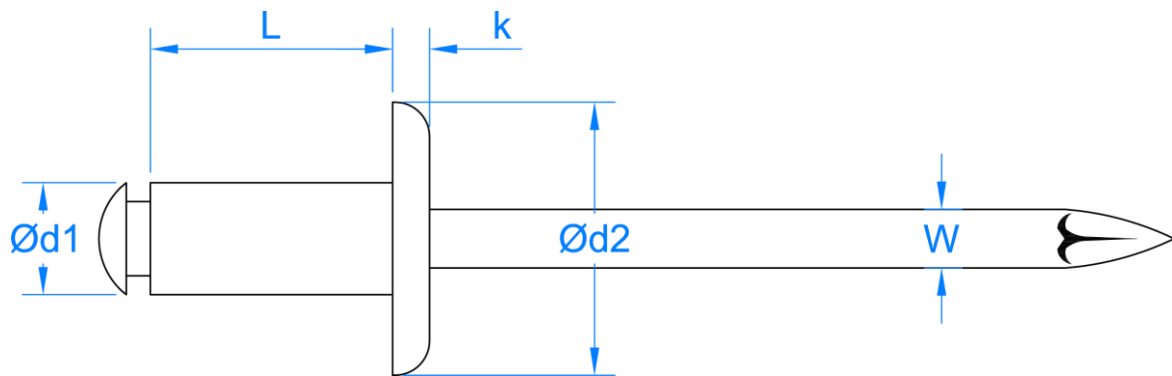

2.4. RE-FL

Peel dome tête rivet

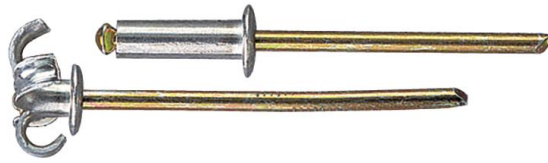

Propretés



Corps en aluminium



Zingué axe

Dimensions

CODE	Ø Foret [mm]	Epaisseur de fixation [mm]	Ø d1 [mm]	L [mm]	Ø d2 [mm]	K [mm]	W [mm]
REFL4012	4,1	4,0 – 6,5	4,0	12	8,0	1,3	2,3
REFL4014		6,0 – 9,0		14			
REFL4016		8,0 – 11,0		16			
REFL4018		10,0 – 13,0		18			
REFL4020		12,0 – 15,0		20			
REFL4025		15,0 – 20,0		25			
REFL4814	5,0	4,0 – 8,0	4,8	14	9,5	1,4	2,8
REFL4816		6,0 – 10,0		16			
REFL4818		8,0 – 12,0		18			
REFL4824		15,0 – 18,0		24			
REFL4830		19,0 – 24,0		30			
REFL4835		24,0 – 29,0		35			
REFL4840		29,0 – 34,0		40			
REFL4845		34,0 – 39,0		45			
REFL4850		38,0 – 42,0		50			

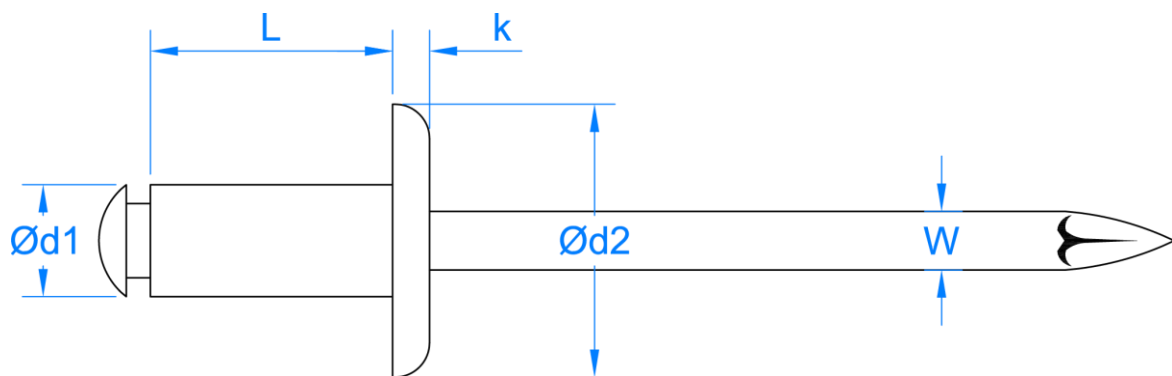

2.5. RE-IN Rivet en acier inoxydable



Propriétés



Corps inoxydable

Corps inoxydable

Dimensions

CODE	Ø Foret [mm]	Epaisseur de fixation [mm]	Ø d1 [mm]	L [mm]	Ø d2 [mm]	K [mm]	W [mm]
REIN3206	3,3	0,5 – 3,0	3,2	06	6,3	1,0	2,0
REIN3208		3,0 – 5,0		08			
REIN3212		6,5 – 8,5		12			
REIN3215		10,5 – 12,5		15			
REIN4008	4,1	2,5 – 4,5	4,0	08	8,0	1,3	2,5
REIN4010		4,5 – 6,5		10			
REIN4012		6,5 – 8,5		12			
REIN4016		10,0 – 12,0		16			
REIN4810	5,0	4,0 – 6,0	4,8	10	9,5	1,4	2,9
REIN4812		6,0 – 8,0		12			
REIN4816		8,0 – 11,0		16			
REIN4818		11,0 – 13,0		18			
REIN4820		13,0 – 15,0		20			

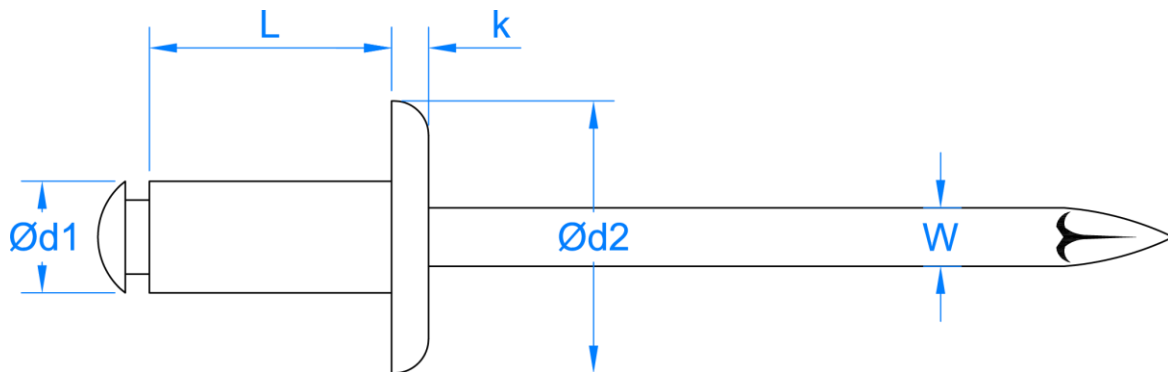

3. PROCÉDURE D'INSTALLATION

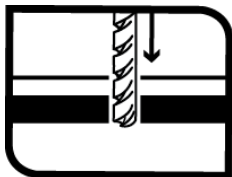

1. PERCER

Percer un trou au diamètre spécifié dans le tableau.
Assurez-vous que les trous sont alignés et les pièces à assembler bien posées.

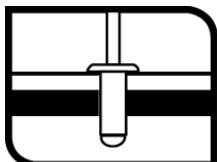

2. INSTALLER

Introduisez le corps du rivet jusqu'à la tête, en laissant dépasser de l'autre côté du trou la partie à riveter.
Veillez à ne pas forcer le rivet, il est recommandé de laisser un minimum de jeu.

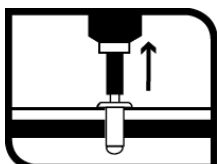

3. RIVETER

Mettez la pince à riveter sur le clou du rivet. Maintenez la pince coaxiale avec le trou.
Veillez à maintenir fermement la pince à riveter coaxiale avec le rivet pour l'installer.

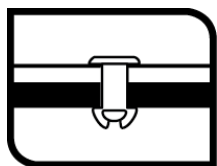

4. CASSER

Actionnez la pince jusqu'à ce que la tige se casse.

4. CHARGE RECOMMANDÉE

CODE	TRACTION [kg]	CISAILLEMENT [kg]
RENO32XX	100	78
RENO40XX	160	118
RENO48XX	228	172
RENO60XX	358	284
RENO32XXBL/NE	100	78
RENO40XXBL/NE	160	118
RENO48XXBL/NE	228	172
RECA40XX	160	118
RECA48XX	228	172
REFL40XX	142	122
REFL48XX	184	164
REIN32XX	295	204
REIN40XX	408	358
REIN48XX	470	572