

TECHNICAL DATASHEET



NA-C



NA-E



NA-F



NA-G



NA-R

CHARACTERISTICS

- Functioning through controlled torque expansion.
- Utilization of light loads.
- Approved for 2 installation depths.
- May be used with cracked and non-cracked concrete.
- Ideal for rooftop installations when necessary.
- Ease of installation– no need for a torque wrench.
- Direct installation using the anchor plate's own drill.
- Installation without anchor plate, depending on head type.
- Different types of heads for different applications.
- Various longitudes and metrics provide assembly flexibility.

APPLICATIONS

- Non-structural fixings in cracked and non-cracked concrete indoors
- All types of installations, especially on roofs.

APPROVALS



BASE MATERIAL



MEASUREMENT RANGE

Ø 6

DRILL CONDITION

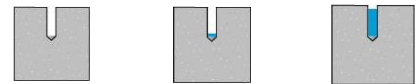

DRY

MOIST

FLOODED

MAXIMUM RECOMMENDED TRACTION LOADS FOR CRACKED AND NON-CRACKED CONCRETE













243 kg.

APPLICATION EXAMPLES



TECHNICAL DATASHEET

1. RANGE						
ITEM	CODE	SIZE	PHOTO	DESCRIPTION	MATERIAL	COATING
1	NA-C	Ø6		Flat-head strike anchor	Galvanised carbon steel	
2	NA-E	Ø6		Studded molly bolt	Galvanised carbon steel	
3	NA-F	Ø6		Hooked molly bolt	Galvanised carbon steel	
4	NA-G	Ø6		Hooked molly bolt	Galvanised carbon steel	
5	NA-R	Ø6		Eyebolt screw anchor	Galvanised carbon steel	

2. INSTALLATION DATA

2.1. INSTALLATION DIAGRAM

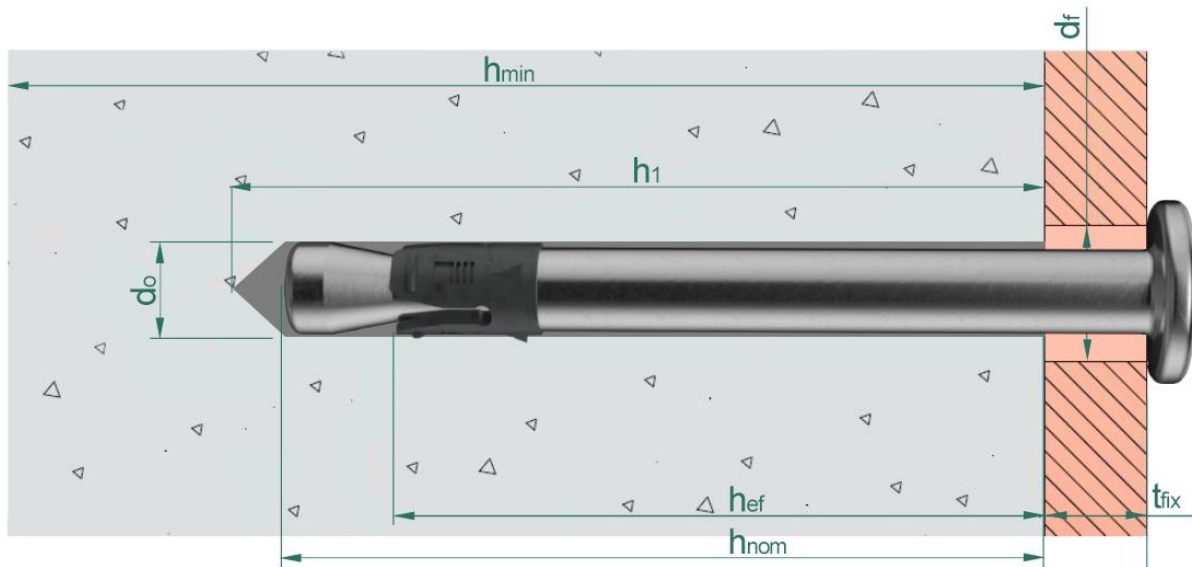



- d_0 : Nominal bit diameter.
- d_f : Diameter of the through hole in the anchor plate
- h_{ef} : Anchor Penetration Depth
- h_1 : Drilling depth
- h_{nom} : Installation depth in concrete
- h_{min} : Minimum thickness of the concrete element
- t_{fix} : Thickness of the anchor plate

3.INSTALLATION PARAMETERS

Overall installation parameters													Standard installation depth ($h_{ef, std}$)			Installation network depth ($h_{ef, red}$)								
Family	Code	Measurement	Approved	Bit diameter	Hole diameter of the thickness level to be set.	Installation key	Maximum installation torque	Minimum distance between anchors	For C ≥	Minimum distance to edge	For S ≥	Minimum concrete thickness	Drilling depth	Installation depth	Effective depth	Thickness level to be set.	Critical distance between axes (cone)	Critical distance to bone (cone)	Drilling depth	Installation depth	Effective depth	Thickness level to be set.	Critical distance between axes (cone)	Critical distance to bone (cone)
[--]	[--]	[--]	ETA	d_0 [mm]	d_f [mm]	SW [--]	T_{inst} [Nm]	S_{min} [mm]	C mm	C_{min} [mm]	S mm	h_{min} [mm]	h_1 [mm]	h_{nom} [mm]	h_{ef} [mm]	t_{fix} [mm]	S_{cr} [mm]	C_{cr} [mm]	h_1 [mm]	h_{nom} [mm]	h_{ef} [mm]	t_{fix} [mm]	S_{cr} [mm]	C_{cr} [mm]
NA-C	NAC6035	Ø6 x 35	✓	6	7	--	--	35	50	35	80	80	40	35	30	--	90	65	35	30	25	5	75	50
	NAC6040	Ø6 x 40	✓													10								
	NAC6045	Ø6 x 45	✓													15								
	NAC6050	Ø6 x 50	✓													20								
	NAC6055	Ø6 x 55	✓													25								
	NAC6065	Ø6 x 65	✓													30								
	NAC6085	Ø6 x 85	✓													50								
NAC6110	Ø6 x 110	✓	75																					
NA-E	NAE6045	Ø6 x 45 (M6)	✓	6	7	10	7	35	50	35	80	80	40	35	30	1	90	65	35	30	25	6	75	50
	NAE6050	Ø6 x 50 (M6)	✓													6								
	NAE6055	Ø6 x 55 (M6)	✓													11								
NA-F	NAF65810	Ø6 x 58 (M8+M10)	✓	6	--	13	--	35	50	35	80	80	40	35	30	--	90	65	35	30	25	--	75	50
	NAF66310	Ø6 x 63 (M8+M10)	✓													--								
NA-G	NAG6055	Ø6 x 55	✓	6	--	--	--	35	50	35	80	80	40	35	30	--	90	65	35	30	25	--	75	50
NA-R	NAR6055	Ø6 x 55	✓	6	--	--	--	35	50	35	80	80	40	35	30	--	90	65	35	30	25	--	75	50

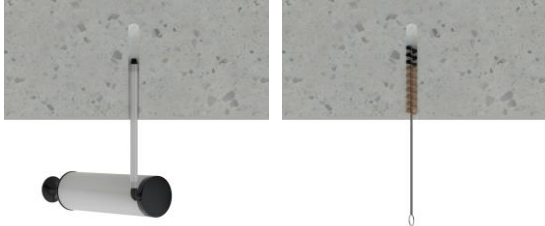

4. INSTALLATION PROCESS



4.1 NA-C

	<p>1. DRILLING</p> <p>Ensure the contract is properly compacted and free of significant pores. Admissible in dry, moist or flooded holes. Drill in percussion or hammer position. Drill to the specified diameter and depth.</p>
	<p>2. BLOWING AND CLEANING</p> <p>Clean the hole from any remaining dust and debris left from drilling, as instructed in the diagram. Use an air pump and brush.</p>
	<p>3. FITTING THE ANCHOR</p> <p>Place the anchor with the item to be secured and manually insert it into the base material until it meets resistance.</p>
	<p>4. INSTALLING</p> <p>Place the anchor into the hole and use a hammer to ensure the head is flush with the surface of the material to be secured.</p>

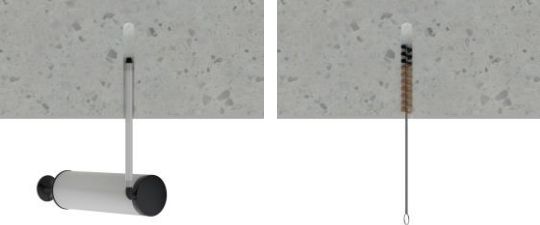
4.2 NA-E	
	<p>1. DRILLING</p> <p>Ensure the contract is properly compacted and free of significant pores. Admissible in dry, moist or flooded holes. Drill in percussion or hammer position. Drill to the specified diameter and depth.</p>
	<p>2. BLOWING AND CLEANING</p> <p>Clean the hole from any remaining dust and debris left from drilling, as instructed in the diagram. Use an air pump and brush.</p>
	<p>3. FITTING THE ANCHOR</p> <p>Place the anchor with the item to be secured and manually insert it into the base material until it meets resistance.</p>
	<p>INSTALLING AND APPLYING THE SPECIFIED TIGHTENING TORQUE</p> <p>Place the anchor into the hole and use a hammer to ensure the head is flush with the surface of the material to be secured. Apply the recommended torque as specified in the installation data table. Use a torque wrench to ensure proper installation.</p>

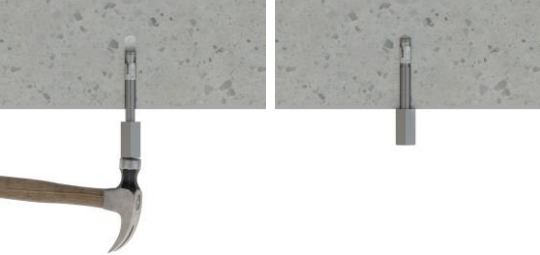
4.3 NA-F

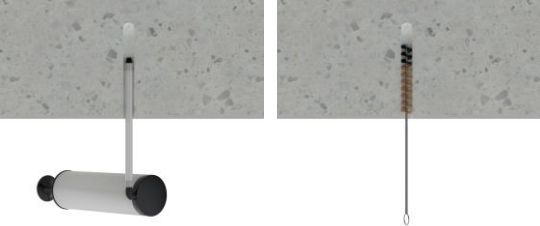
	<p>1. DRILLING</p> <p>Ensure the contract is properly compacted and free of significant pores. Admissible in dry, moist or flooded holes. Drill in percussion or hammer position. Drill to the specified diameter and depth.</p>
	<p>2. BLOWING AND CLEANING</p> <p>Clean the hole from any remaining dust and debris left from drilling, as instructed in the diagram. Use an air pump and brush.</p>
	<p>3. FITTING THE ANCHOR</p> <p>Place the anchor with the item to be secured and manually insert it into the base material until it meets resistance.</p>
	<p>4. INSTALLING</p> <p>Insert the anchor into the hole until the head is even with the surface of the material to be fastened, using a hammer.</p>

4.4 NA-G/R	
	<p>1. DRILLING</p> <p>Ensure the contract is properly compacted and free of significant pores. Admissible in dry, moist or flooded holes. Drill in percussion or hammer position. Drill to the specified diameter and depth.</p>
	<p>2. BLOWING AND CLEANING</p> <p>Clean the hole from any remaining dust and debris left from drilling, as instructed in the diagram. Use an air pump and brush.</p>
	<p>3. FITTING THE ANCHOR</p> <p>Place the anchor with the item to be secured and manually insert it into the base material until it meets resistance.</p>
	<p>4. INSTALLING</p> <p>Place the anchor into the hole and use a hammer to ensure the head is flush with the surface of the material to be secured.</p>

5. VARIOUS RESISTANCE LEVELS

Alternative: Concrete resistance or strength ranging from C20/25 to C50/60 for loads in any direction, along with values for an isolated anchor, disregarding edge distance and anchor spacing effects, are provided in the following table:

The underlined and italicized value signify steel failure; the values **bolded** indicate concrete failure.
1 kN ≈ 100 kg

5.1 RESISTANCE FEATURES [kN]

Overall parameters				Cracked and non-cracked concrete	
Family	Code	Measurement	ETE Certified.	F_{Rk}^0 ($h_{ef, std}$)	F_{Rk}^0 ($h_{ef, red}$)
NA-C	NAC6035	Ø6 x 35	✓	5.00	3.00
	NAC6040	Ø6 x 40	✓		
	NAC6045	Ø6 x 45	✓		
	NAC6050	Ø6 x 50	✓		
	NAC6055	Ø6 x 55	✓		
	NAC6065	Ø6 x 65	✓		
	NAC6085	Ø6 x 85	✓		
	NAC6110	Ø6 x 110	✓		
NA-E	NAE6045	Ø6 x 45 (M6)	✓	5.00	3.00
	NAE6050	Ø6 x 50 (M6)	✓		
	NAE6055	Ø6 x 55 (M6)	✓		
NA-F	NAF65810	Ø6 x 58 (M8+M10)	✓	5.00	3.00
	NAF66310	Ø6 x 63 (M8+M10)	✓		
NA-G	NAG6055	Ø6 x 55	✓	1.50	1.50
NA-R	NAR6055	Ø6 x 55	✓	1.50	1.50

5.2 CALCULATION RESISTANCES [kN]

Overall parameters				Cracked and non-cracked concrete	
Family	Code	Measurement	ETE Certified.	F_{Rd}^0 ($h_{ef, std}$)	F_{Rd}^0 ($h_{ef, red}$)
NA-C	NAC6035	Ø6 x 35	✓	3.33	1.67
	NAC6040	Ø6 x 40	✓		
	NAC6045	Ø6 x 45	✓		
	NAC6050	Ø6 x 50	✓		
	NAC6055	Ø6 x 55	✓		
	NAC6065	Ø6 x 65	✓		
	NAC6085	Ø6 x 85	✓		
	NAC6110	Ø6 x 110	✓		
NA-E	NAE6045	Ø6 x 45 (M6)	✓	3.33	1.67
	NAE6050	Ø6 x 50 (M6)	✓		
	NAE6055	Ø6 x 55 (M6)	✓		
NA-F	NAF65810	Ø6 x 58 (M8+M10)	✓	3.33	1.67
	NAF66310	Ø6 x 63 (M8+M10)	✓		
NA-G	NAG6055	Ø6 x 55	✓	1.00	0.83
NA-R	NAR6055	Ø6 x 55	✓	1.00	0.83

5.3 MAXIMUM RECOMMENDED LOADS (with and $F= 1.4$) [kN]

Overall parameters				Cracked and non-cracked concrete	
Family	Code	Measurement	ETE Certified.	F_{rec}^0 ($h_{ef, std}$)	F_{rec}^0 ($h_{ef, red}$)
NA-C	NAC6035	Ø6 x 35	✓	2.38	1.19
	NAC6040	Ø6 x 40	✓		
	NAC6045	Ø6 x 45	✓		
	NAC6050	Ø6 x 50	✓		
	NAC6055	Ø6 x 55	✓		
	NAC6065	Ø6 x 65	✓		
	NAC6085	Ø6 x 85	✓		
	NAC6110	Ø6 x 110	✓		
NA-E	NAE6045	Ø6 x 45 (M6)	✓	2.38	1.19
	NAE6050	Ø6 x 50 (M6)	✓		
	NAE6055	Ø6 x 55 (M6)	✓		
NA-F	NAF65810	Ø6 x 58 (M8+M10)	✓	2.38	1.19
	NAF66310	Ø6 x 63 (M8+M10)	✓		
NA-G	NAG6055	Ø6 x 55	✓	0.71	0.60
NA-R	NAR6055	Ø6 x 55	✓	0.71	0.60

6. OFFICIAL DOCUMENTATION

At our sales department or on our webpage www.indexfix.com, you may obtain these documents:

- European approval ETA 24/0011 for installation in cracked and non-cracked concrete under guideline 330747-00-0601, for Ø6.
- DoP NA Performance Statement