

KT-PSC



ASSESSMENTS



PRODUCT DESCRIPTION

Triangular kit with PSE-C aluminium profile. Assembled fixing

CHARACTERISTICS

- Assembly kit containing the components necessary for the installation of a determined number of photovoltaic modules.
- Installation based on triangular mounting **ST-PSC** system.
- Includes quick fixing clamps **KFRSC3050** for modules.
- Includes **GM-A** gauges for heights of 30, 35 and 40 mm.
- Includes **PSE-C** aluminium profile structure in continuous format.
- Includes **PSECUN200** profile joint with **DIN-7504-K A2** installation screw set.
- Includes **TPA-R** pre-assembled triangles with three inclination options – 25°, 30° and 35°.
- Includes **KFSFCM08** lateral fixing connectors to join **PSE-C** profiles and **TPA-R** triangles from the kit.

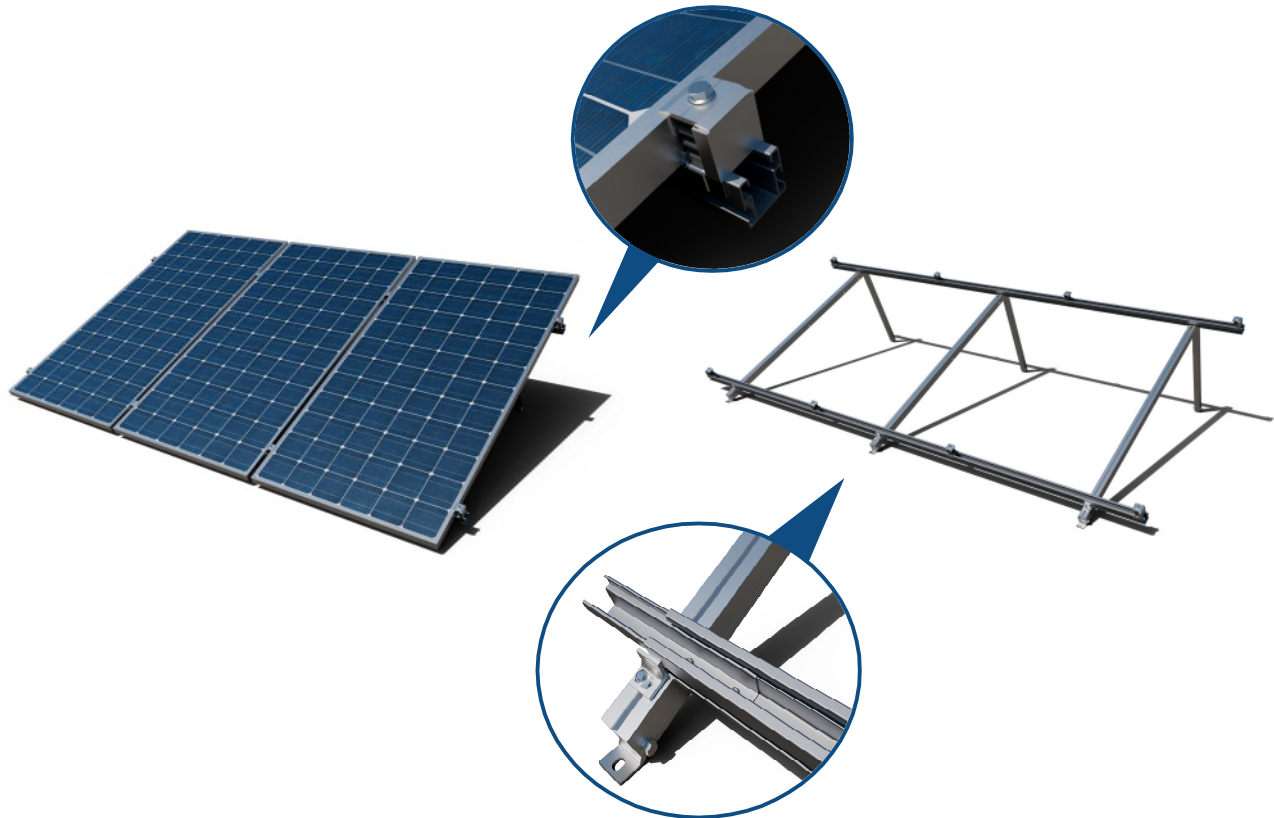

COMPONENTS

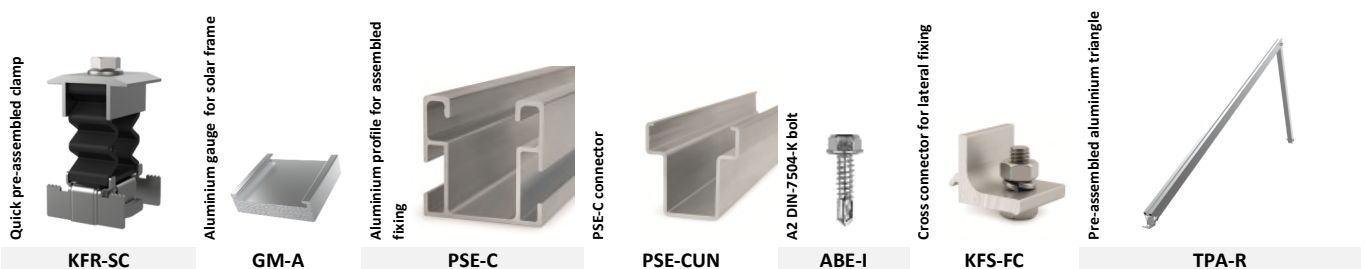

APPLICATIONS

- Assembly of photovoltaic modules that are inclined with respect to the roof surface on flat and slightly sloping roofs.
- Installation on all roof types on pre-assembled triangles with adjustable 25°, 30° and 35° inclination.
- For modules with 35 mm- or 40 mm-high frames.
- For modules sizes up to 1150 mm wide
- Portrait view (vertical) orientation modules assembly.
- Options include direct assembly to the roof sub-structure or mounting on an auxiliary structure – consult specifications on the **ST-PSC** assembly system technical data sheet









1.RANGE

ITEM	CODE	PHOTO	DESCRIPTION	MODULES	FRAME	LENGTH ROW	MATERIAL		
1	KTPSC0230		Triangular kit with PSE-C aluminium profile. Assembled fixing For two modules	2	30 mm	2500 mm			
	KTPSC0235			2	35 mm	2500 mm			
	KTPSC0240			2	40 mm	2500 mm			
							Aluminium	AISI-304	EPDM
2	KTPSC0330		Triangular kit with PSE-C aluminium profile. Assembled fixing For three modules	3	30 mm	3750 mm			
	KTPSC0335			3	35 mm	3750 mm			
	KTPSC0340			3	40 mm	3750 mm			
							Aluminium	AISI-304	EPDM
3	KTPSC02AM		Triangular kit with PSE-C aluminium profile. Assembled fixing For enlargement two modules	2	--	2500 mm			
	KTPSC03AM			3	--	3750 mm			
							Aluminium	AISI-304	EPDM

2.INSTALLATION DATA

2.1 KTPSC02

Triangular kit with PSE-C aluminium profile. Assembled fixing
For two modules

	 <p>2 modules</p>	Component kit						
		 <p>Quick pre-assembled clamp</p>	 <p>Aluminium gauge for solar frame</p>	 <p>Aluminium profile for assembled</p>	 <p>PSE-C connector</p>	 <p>A2 DIN-7504-K bolt</p>	 <p>Cross connector for lateral fixing</p>	 <p>Pre-assembled aluminium triangle</p>
<p>Reference</p>								
KTPSC0230 (H=30mm)	KFRSC3050 6 units	GMA030 4 units	PSEC411250 4 units	PSECUN200 2 units	ABEI5519 8 units	KFSFCM08 8 units	TPAR251500 2 units	
KTPSC0235 (H=35mm)	KFRSC3050 6 units	GMA035 4 units	PSEC411250 4 units	PSECUN200 2 units	ABEI5519 8 units	KFSFCM08 8 units	TPAR251500 2 units	
KTPSC0240 (H=40mm)	KFRSC3050 6 units	GMA034 4 units	PSEC411250 4 units	PSECUN200 2 units	ABEI5519 8 units	KFSFCM08 8 units	TPAR251500 2 units	

Roof/Fixing accessories

Consult technical data sheet corresponding to the ST-PSC assembly system.

Measurement table

Code	A (mm)	B (mm)	C (mm)	D (mm)	E (mm)	F (mm)	H (mm)	J (mm)	K (mm)	L (mm)	LF (mm)	M (mm)	T (mm)
KTPSC0230	≤ 1150	≤ 2100	0,5B ÷ 0,7B	0,1B ÷ 0,25B	26	≥ 35	30	1400÷1600	(LF-J) / 2	1250	2500	(T-C) / 2	1500
KTPSC0235	≤ 1150	≤ 2100	0,5B ÷ 0,7B	0,1B ÷ 0,25B	26	≥ 35	35	1400÷1600	(LF-J) / 2	1250	2500	(T-C) / 2	1500
KTPSC0240	≤ 1150	≤ 2100	0,5B ÷ 0,7B	0,1B ÷ 0,25B	26	≥ 35	40	1400÷1600	(LF-J) / 2	1250	2500	(T-C) / 2	1500

Drawing

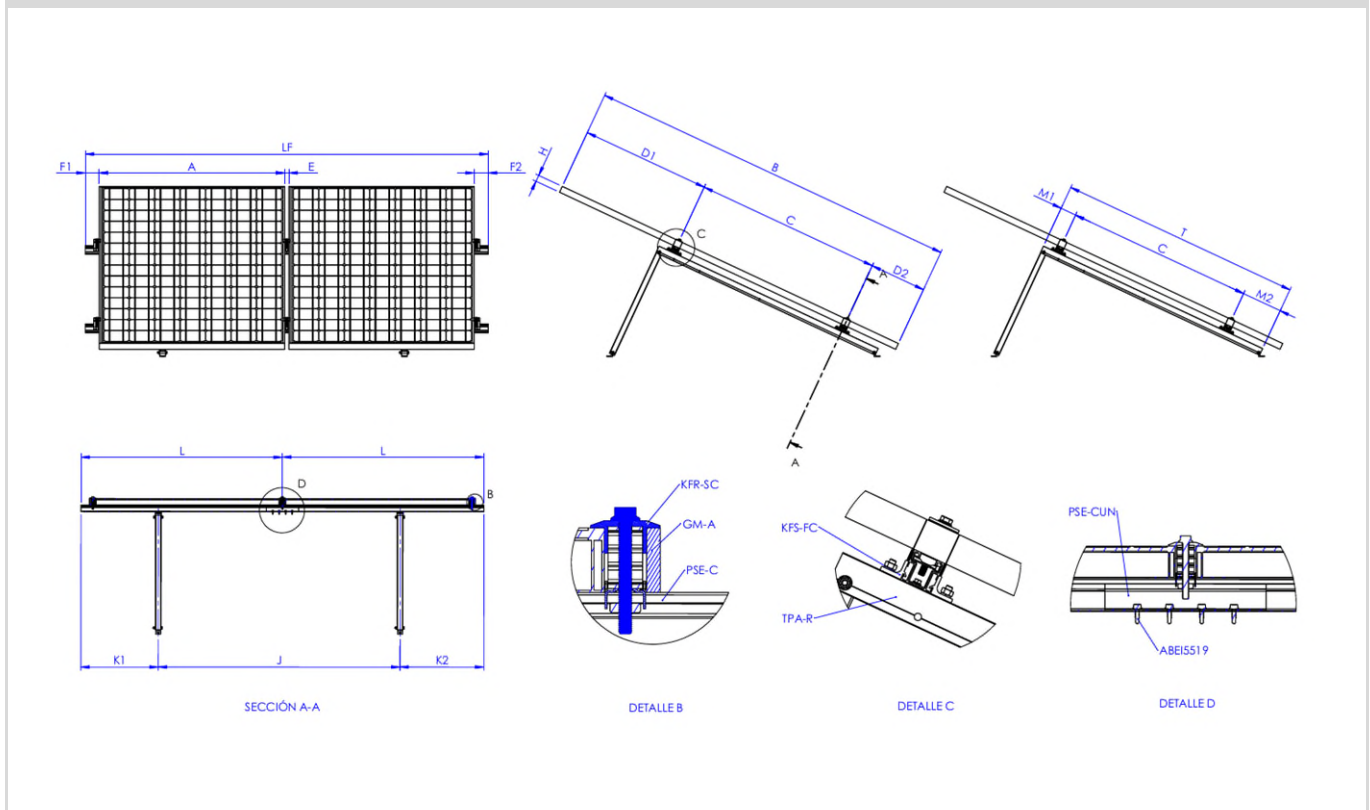

Measurement table 2

Code	Position 1			Position 2			Position 3		
	β (°)	Ls (mm)	Lb (mm)	β (°)	Ls (mm)	Lb (mm)	β (°)	Ls (mm)	Lb (mm)
TPAR251500	25	18	1696	30	118	1260	35	293	1052

Drawing

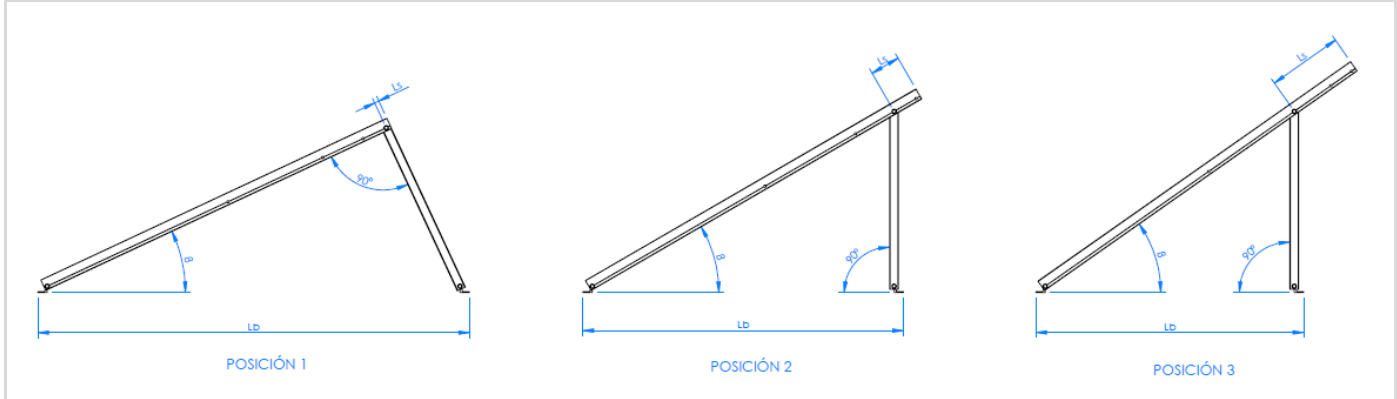

Mechanical properties of the profile.

	Area S (cm ²)	Moment of inertia I _x (cm ⁴)	Moment of inertia I _y (cm ⁴)	Section modulus W _x (cm ³)	Section modulus W _y (cm ³)	Linear weight W (kg/m)
 Upper profile	3,01	5,15	7,52	1,76	3,76	0,81
 Profile bar	2,59	4,66	4,66	2,66	2,66	0,70
 Profile fot	3,91	3,99	4,66	1,94	1,61	1,04

2.2 KTPSC03

Triangle kit with aluminium profile (PSE-C). Assembled fixing For three modules



3 modules
Reference

Reference	Quick pre-assembled clamp	Aluminium gauge for solar frame	Aluminium profile for assembled fixing	PSE-C connector	A2 DIN-7504-K bolt	Cross connector for lateral fixing	Pre-assembled aluminium triangle
KTPSC0330 (H=30mm)	KFRSC3050 8 units	GMA030 4 units	PSEC411875 4 units	PSECUN200 2 units	ABE15519 8 units	KFSFC08 12 units	TPAR251500 3 units
KTPSC0335 (H=35mm)	KFRSC3050 8 units	GMA035 4 units	PSEC411875 4 units	PSECUN200 2 units	ABE15519 8 units	KFSFC08 12 units	TPAR251500 3 units
KTPSC0340 (H=40mm)	KFRSC3050 8 units	GMA040 4 units	PSEC411875 4 units	PSECUN200 2 units	ABE15519 8 units	KFSFC08 12 units	TPAR251500 3 units

Roof/Fixing accessories

Consult technical data sheet corresponding to the ST-PSC assembly system.

Measurement table

Code	A (mm)	B (mm)	C (mm)	D (mm)	E (mm)	F (mm)	G (mm)	H (mm)	J (mm)	K (mm)	L (mm)	LF (mm)	LU (mm)	M (mm)	T (mm)
KTPSC0330	≤ 1150	≤ 2100	0,5B ÷ 0,7B	0,1B ÷ 0,25B	26	≥ 35	50÷70	30	1300÷1500	(LF-2J) / 2	1875	3750	200	(T-C) / 2	1500
KTPSC0335	≤ 1150	≤ 2100	0,5B ÷ 0,7B	0,1B ÷ 0,25B	26	≥ 35	50÷70	35	1300÷1500	(LF-2J) / 2	1875	3750	200	(T-C) / 2	1500
KTPSC0340	≤ 1150	≤ 2100	0,5B ÷ 0,7B	0,1B ÷ 0,25B	26	≥ 35	50÷70	40	1300÷1500	(LF-2J) / 2	1875	3750	200	(T-C) / 2	1500

Drawing

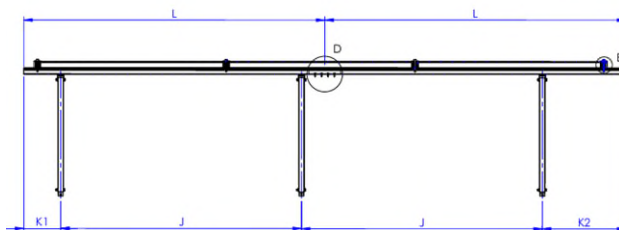
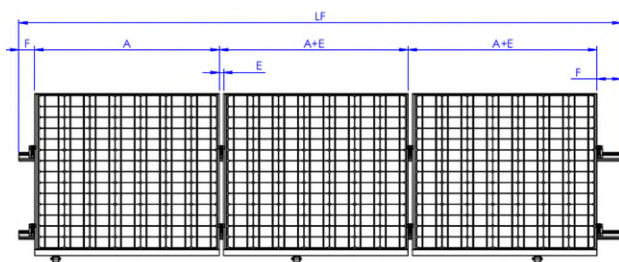

SECCIÓN A-A

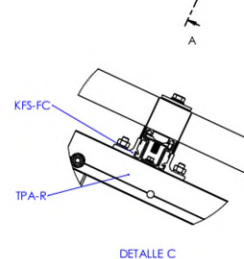
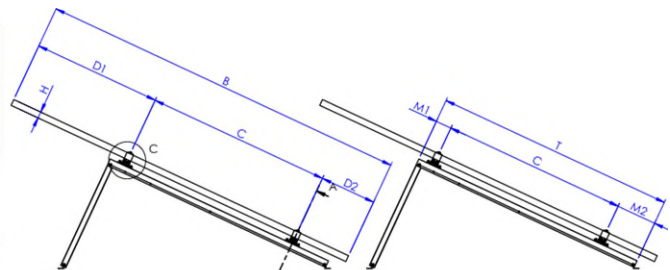

DETALLE C

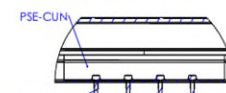

DETALLE D

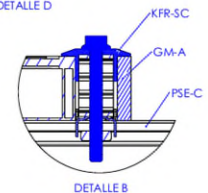

DETALLE B

Measurement table 2

Code	Position 1			Position 2			Position 3		
	β (°)	Ls (mm)	Lb (mm)	β (°)	Ls (mm)	Lb (mm)	β (°)	Ls (mm)	Lb (mm)
TPAR251500	25	18	1696	30	118	1260	35	293	1052

Drawing

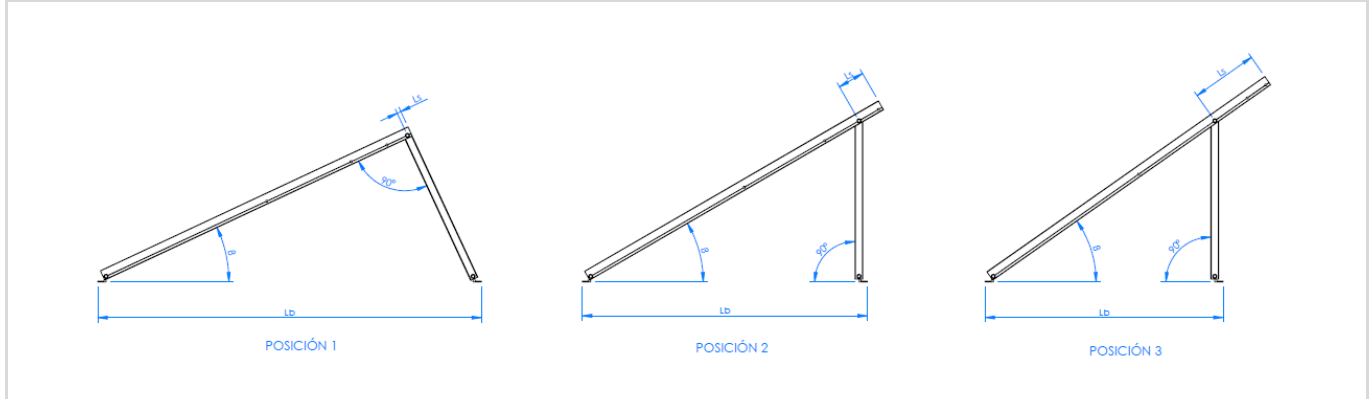









Mechanical properties of the profile.

	Area S (cm ²)	Moment of inertia I _x (cm ⁴)	Moment of inertia I _y (cm ⁴)	Section modulus W _x (cm ³)	Section modulus W _y (cm ³)	Linear weight W (kg/m)
 Upper profile	3,01	5,15	7,52	1,76	3,76	0,81
 Profile bar	2,59	4,66	4,66	2,66	2,66	0,70
 Profile fot	3,91	3,99	4,66	1,94	1,61	1,04

2.3 KTPSCAM

Triangular kit with aluminium profile (PSE-C). Assembled fixing. Enlargement for 2 and 3 modules

 	2 & 3 modules Reference	Component Kit					
		 Quick pre-assembled clamp	 Aluminium profile for assembled fixing	 PSE-C connector	 A2 DIN-7504-K bolt	 Cross connector for lateral fixing	 Pre-assembled aluminium triangle
KTPSC02AM	KFRSC3050 4 units	PSEC411250 4 units	PSECUN200 4 units	ABE15519 16 units	KFSFCM08 8 units	TPAR251500 2 units	
KTPSC03AM	KFRSC3050 6 units	PSEC411875 4 units	PSECUN200 4 units	ABE15519 16 units	KFSFCM08 12 units	TPAR251500 3 units	

Roof/Fixing accessories

Consult technical data sheet corresponding to the ST-PSC assembly system.

Measurement table

Code	A (mm)	B (mm)	C (mm)	D (mm)	E (mm)	F (mm)	G (mm)	J (mm)	K (mm)	L (mm)	LF (mm)	LU (mm)	M (mm)	T (mm)
KTPSC02AM	≤ 1150	≤ 2100	0,5B ÷ 0,7B	0,1B ÷ 0,25B	26	≥ 35	50÷70	1300÷1500	(LF-2J) / 2	1250	2500	200	(T-C) / 2	1500
KTPSC03AM	≤ 1150	≤ 2100	0,5B ÷ 0,7B	0,1B ÷ 0,25B	26	≥ 35	50÷70	1300÷1500	(LF-2J) / 2	1875	3750	200	(T-C) / 2	1500

Drawing

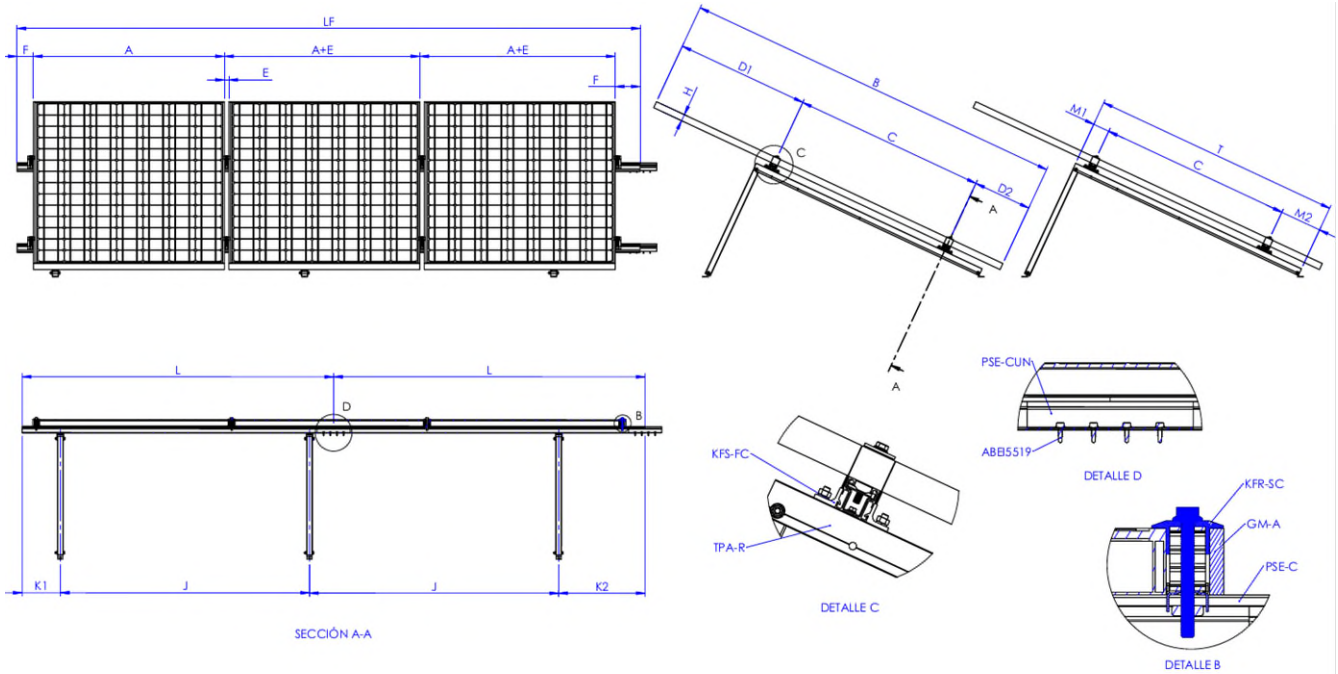

Example of enlargement kit composition 3 modules

Measurement table 2

Code	Position 1			Position 2			Position 3		
	β (°)	Ls (mm)	Lb (mm)	β (°)	Ls (mm)	Lb (mm)	β (°)	Ls (mm)	Lb (mm)
TPAR251500	25	18	1696	30	118	1260	35	293	1052

Drawing

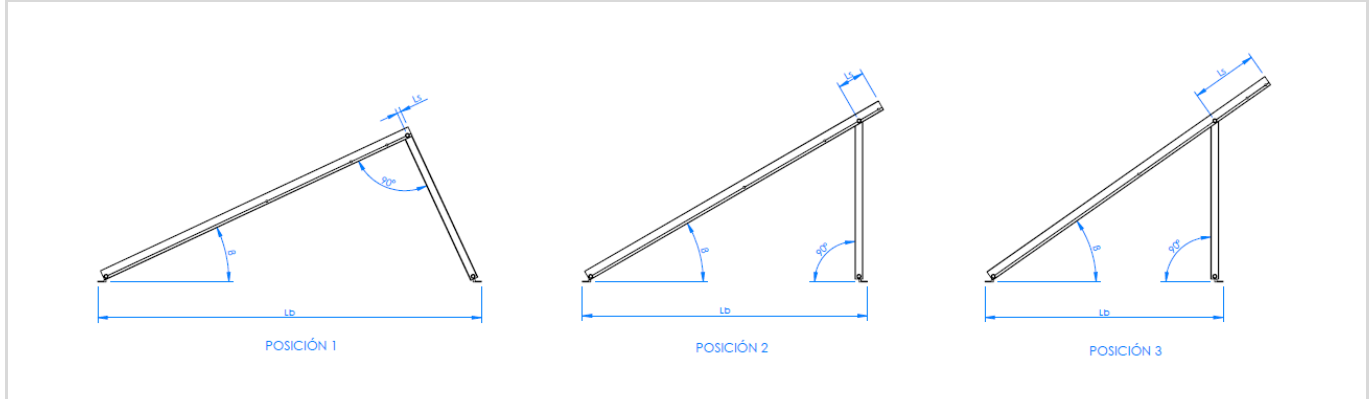

Mechanical properties of the profile.

	Area S (cm ²)	Moment of inertia I _x (cm ⁴)	Moment of inertia I _y (cm ⁴)	Section modulus W _x (cm ³)	Section modulus W _y (cm ³)	Linear weight W (kg/m)
 Upper profile	3,01	5,15	7,52	1,76	3,76	0,81
 Profile bar	2,59	4,66	4,66	2,66	2,66	0,70
 Profile fot	3,91	3,99	4,66	1,94	1,61	1,04