



TAEZ



TAEN



BCPZ



BCPN



BCPB



BCPZ__BL



BCPA2



RSZ



RSA2

CHARACTERISTICS

- Drill point: drill material directly – no need for pre-drilled hole.
- Self-tapping thread.
- Wide variety of head types, diameters and lengths for different applications: flexibility in installation.
- Available in zinc plated, black zinc-plated and white zinc-plated.
- Versions in standard commercial lacquered plate colours (RAL colour scheme).
- Coloured caps available for hexagonal heads.

APPLICATIONS

- For joining metal to wood, joining metallic elements, or plastic, wood or other materials on metallic materials.
- Versions with galvanized steel-EPDM or stainless steel-EPDM washer for sealed joints in façades and roofing, in different diameters.









BASE MATERIALS



APPLICATION EXAMPLES



1.RANGE

ITEM	DENOMINACION	PHOTO	REGULATION	HEAD	SOCKET	ØEPDM WASHER (1)	MATERIAL/ COATING (2) (3)	MATERIAL TO BE FIXED
1	TAEZ		---	Flat head	Ph	---	Steel / Zinc-plated	Steel
2	TAEN		---	Flat head	Ph	---	Steel / Black Zinc-plated	Steel
3	BCPZ		---	Extra-flat bevelled	Ph	---	Steel / Zinc-plated	Steel
4	BCPN		---	Extra-flat bevelled	Ph	---	Steel / Black Zinc-plated	Steel
5	BCPB		---	Extra-flat bevelled	Ph	---	Steel / Zinc-plated + paint	Steel
6	BCPZ__BL		---	Extra-flat bevelled	Ph	---	Steel / Zinc-plated + paint	Steel
7	BCPA2		---	Extra-flat bevelled	Ph	---	Stainless Steel	Aluminium
8	RSZ		---	Flat bevelled	Ph	---	Steel / Zinc-plated	Steel
9	RSA2		---	Flat bevelled	Ph	---	Stainless Steel	Aluminium

(1) EPMD washer characteristics according to ARVUL Data Sheet

(2) Coatings: Zinc-plated $\geq 3 \mu\text{m}$ according to ISO 4042 A1J

Black zinc-plated $\geq 3 \mu\text{m}$ according to ISO 4042 A1N

(3) Available in various coatings and colors upon request.

MATERIALES

Characteristic	ABE, ARE, AUTO, ABR, ABRBL, NBR, ABRC, ABA, FS, ABP, NBP, ABPC, TAEZ, TAEN, BCPZ, BCPN, BCPB, RS	ABRA2, ABRCA2, ABPCA2, BCPA2	BIE, BAUTO (silver ruspert coating)
Material	Special steel for SAE J403 1022 thermal treatment	A2 Stainless Steel	A2 Stainless Steel head and shaft. Special steel point for SAE J403 1022 thermal treatment
Surface hardness	> 500 HV	---	Head and shaft --- Point > 500 HV
Core hardness	240 - 450 HV	---	Head and shaft --- Point 240 - 450 HV
Depth hardness	ST 2.5 – 3.5: 0.05 – 0.18 mm. ST 3.9 – 5.5: 0.10 – 0.23 mm. ST 6.3: 0.15 – 0.28 mm.	---	Head and shaft --- Point: ST 4.8 – 5.5: 0.10 – 0.23 mm. ST 6.3: 0.15 – 0.28 mm.

POINT SELECTION

The choice of screw point must be such that the total thickness of materials to be joined (including any intermediate spaces) is lower than the edge of the drill point; otherwise screw breakage may occur during installation.

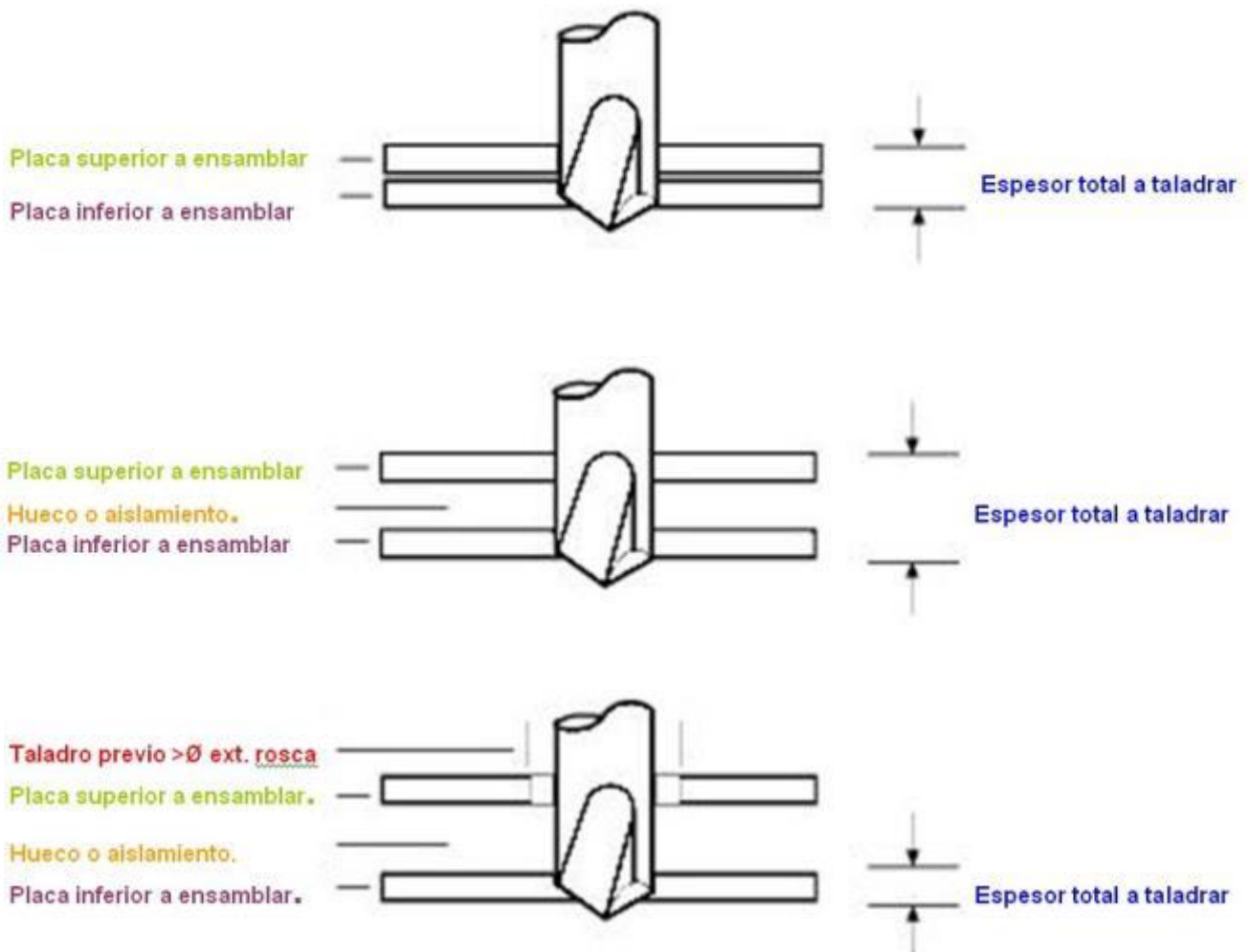

INSTALLATION PARAMETERS

Parameter		ST 3.5	ST 3.9	ST 4.2	ST 4.8	ST 5.5 M 5.5	ST 6.3
Drill Speed	Steel	[rpm]	1800 - 2500			1000 - 1800	
	Stainless Steel	[rpm]	1000 - 1500			600 - 1000	

With high drilling times or excessive drilling speed there is a risk of burning the drill bit and therefore not drilling the material.

SCREW	ØTHREAD	THICKNESS TO BE FIXED IN STEEL [mm]				
RS	6.3		2,5		6,0	
	5.5		1,75		5,25	
	4.8		1,75		4,4	
	4.2		1,75	3,0		
	3.9	0,7		2,4		
	3.5	0,7		2,25		
TAE	4.2		1,75	3,0		
BCP	4.2	0,7	2,0			

0,00 0,25 0,50 0,75 1,00 1,25 1,50 1,75 2,00 2,25 2,50 2,75 3,00 3,25 3,50 3,75 4,00 4,25 4,50 4,75 5,00 5,25 5,50 5,75 6,00 6,5 7,0 7,5 8,0 8,5 9,0 9,5 10,0 10,5 11,0 11,5 12,0

MAXIMUM THICKNESS TO BE FIXED

Length	ST 3,5	ST 3,9	ST 4,2	ST 4,8	ST 5,5	ST 6,3
9,5	2,85					
11	4,2					
13	6,2	5,8	4,3	3,7		
16	9,2	8,8	7,3	5,5		
19	12,1	11,7	10,3	8,7	8,7	7
22	15,1	14,7	13,3	11,7	11,7	10
25	18,1	17,7	16,3	14,7	14,7	13
32	25,1	24,5	23	21,5	21,5	20
38		30,5	29	27,5	27,5	26
45			36	34,5	34,5	33
50			41	39,5	39,5	38
60				49,5	49,5	48
63				52,5	52,5	51
73				62,5	62,5	61
75				64,5	64,5	63
80				69,5		68
90				79,5		78
100				89,5		88
110						98
120						108
130						118
140						128

SCREW RESISTANCE CHARACTERISTICS*

SIZE	TENSION [kN]	SHEAR [kN]
ST 2.9	2.62	1.31
ST 3.5	3.81	1.91
ST 3.9	4.64	2.32
ST 4.2	5.26	2.63
ST 4.8	7.11	3.56
ST 5.5	9.63	4.82
ST 6.3	13.36	6.68

1 kN ≈ 100 Kg

For tension loads, the inherent resistance of plates to be fixed must be taken into account, which is usually less than the resistance of the screw itself, as the screw will probably tear the plates.

RECOMMENDED TENSION LOAD IN STEEL PLATE

SIZE	RECOMMENDED LOAD					
	e[mm]	N[kN]	e[mm]	N[kN]	e[mm]	N[kN]
ST 3.5	0.8	0.55	1.5	0.89	2.0	1.13
ST 3.9	0.8	0.54	1.5	0.97	2.0	1.50
ST 4.2	2.0	1.63	2.5	1.51	3.0	2.62
ST 4.8	2.0	1.87	3.0	2.77	4.0	3.71
ST 5.5	2.0	1.77	3.5	2.86	5.0	3.43
ST 6.3	2.5	1.44	4.0	3.19	5.0	4.83

RECOMMENDED TENSION LOAD IN ALUMINIUM PLATE

SIZE	RECOMMENDED LOAD					
	e[mm]	N[kN]	e[mm]	N[kN]	e[mm]	N[kN]
ST 4.8	2.0	0.95	3.0	1.52	4.0	2.10
ST 5.5	2.0	0.66	3.0	2.48	4.0	3.44
ST 6.3	2.0	0.78	3.0	2.47	4.0	4.51

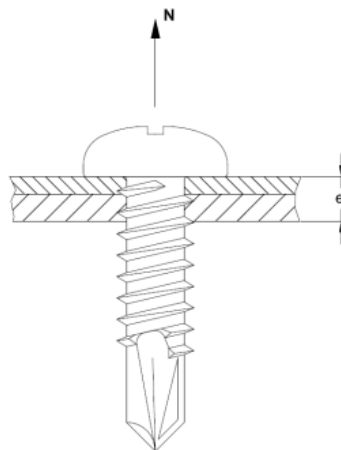

2. INSTALLATION DATA

2.1 TAEZ,TAEN

Self-drilling screw – low dome head – Ph socket with embossed washer



Properties



Steel



Zinc-plated coating



Black zinc-plated

Base material



Metal plate assembly



Plate profile

Properties



Ph



Low dome head



Screw point

Installation data

CODE	ST 4.2
d_k : head diameter \leq	[mm] 11.17
Head thickness \leq	[mm] 2.55
Ph bit	[mm] n° 2
k: point length	[mm] 4.4 – 5.2
D: exterior thread diameter	4.22
d: interior thread diameter	[mm] 3.10
p: thread	[mm] 1.4
l: lengths	[mm] 13 - 32
Installation bit code (Ph bit)	PUPHC02/PUPHL02
Drill capacity	1.00 - 2.50

DRAWING

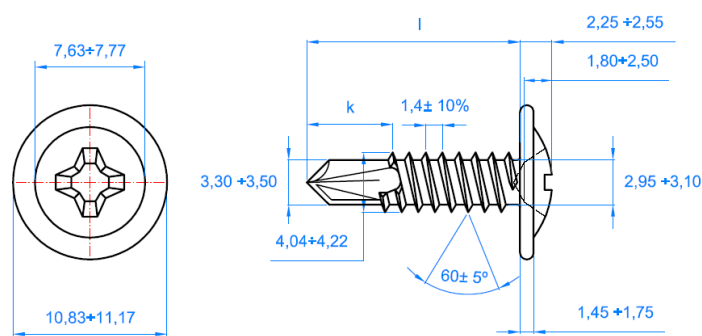

- Zinc-plated (code TAEZ) or black zinc-plated (code TAEN) finish.
- For use in fixings where an even distribution of pressure is required, without the need for assembling additional flat washers, and without the head protruding excessively:
 - For fixing soft materials on metal (methacrylate, plastic, chipboard, thin metallic plates, etc).
 - Large or oversized holes.

2.2

**BCPZ, BCPN, BCPB,
BCPZ_BL, BCPA2**

Self-drilling screw – extra-flat head – Ph socket



Properties		Base material	
Steel	Available in stainless	Metal plate assembly	Plate profile

Recubrimientos

Properties

Zinc-plated coating	Black zinc-plated	White zinc-plated	White head only BCPZ_BL	Ph	Extra-flat head	Screw point

Installation data

CODE		ST 4.2
d _k : head diameter	[mm]	8.0
k: head thickness	[mm]	0.7
Ph bit		nº 2
Point length	[mm]	4
D: exterior thread diameter	[mm]	4.22
d: interior thread diameter	[mm]	3.10
p: thread	[mm]	1.4
l: lengths	[mm]	14 - 23
Head countersink angle	º	65
Installation bit code (Ph bit)		PUPHC02 PUPHL02
Drill capacity	[mm]	0.7 - 2.0

DRAWING

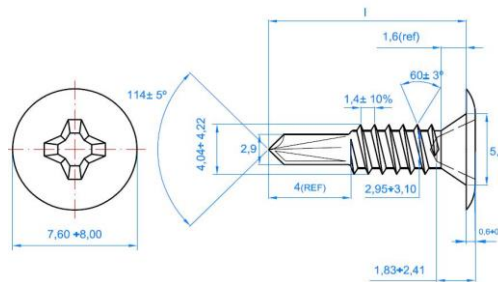

- Zinc-plated (code BCPZ), black zinc-plated (code BCPN) or completely white painted RAL 9010 (code BCPB) finishes.
- Bevelled head to prevent snagging on sliding parts.
- For joints on metal which require a low head (sliding doors and windows, inlaid locks, etc.).
- May be used as a substitute for rivets in many applications, with the advantage of being removable.
- Reduced cone under head to improve finish on flat surfaces.
- A2 Stainless steel version (code BCPA2) for use exclusively with aluminium (does not produce corrosion by galvanic coupling). Do not use screw in stainless steel to drill steel, as point will burn out due to lack of hardness.

2.3

RS

Self-drilling screw - rivet head

	Properties	
	Steel	Zinc-plated coating

Base material			Properties		
Metal plate assembly	Plate profile	Aluminium	Ph	Extra-flat flat head	Screw point

Installation data					
CODE		ST 3.5	ST 4.2	ST 4.8	DRAWING
d_k : head diameter	[mm]	6.7	8	9.3	
k: head thickness	[mm]	1.27	1.35	1.50	
d: exterior thread diameter	[mm]	3.5	4.2	4.8	
p: thread	[mm]	1.3	1.4	1.6	
l: lengths	[mm]	9 - 16	13 - 32	13 - 38	
Ph bit	[mm]	nº 2	nº 2	nº 2	
Installation bit code (Ph bit)	[mm]	PUPHC02 PUPHL02	PUPHC02 PUPHL02	PUPHC02 PUPHL02	
Drill capacity	[mm]	0.7 – 2.25	1.75 – 3.00	1.75 – 4.40	

- Self-drilling screw with reduced head height.
- This reduced head height gives it special characteristics:
 - Avoids interference with moving elements.
 - Aesthetic finish as screw is rounded and is concealed once installed.
 - May be used as a substitute for rivets.
 - Wide range of thicknesses to be drilled - from 0.70 mm to 4.40 mm.
 - Wide range of measurements.
 - Cone between thread and head to ensure piece sits perfectly.
 - Complete thread.
 - Annular groove at the bottom of the head which allows the material originated in the drilling process to stay in this area, allowing the screw to sit better.

2.3 RS-A2 Self-drilling screw - rivet head Stainless Steel



Properties



Stainless Steel A2

Base material



Aluminium

Properties



Ph



Extra-flat head



Screw point

Installation data

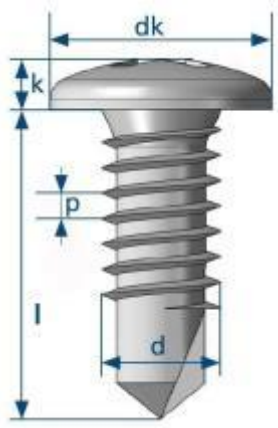
CODE		ST 3.5	ST 4.2	ST 4.8	DRAWING 
dk: head diameter	[mm]	6.7	8	9.3	
k: head thickness	[mm]	1.50	1.65	1.85	
d: exterior thread diameter	[mm]	3.5	4.2	4.8	
p: thread	[mm]	1.3	1.4	1.6	
l: lengths	[mm]	9,5	16 - 19	16 - 25	
Ph bit	[mm]	nº 2	nº 2	nº 2	
Installation bit code (Ph bit)	[mm]	PUPHC02 PUPHL02	PUPHC02 PUPHL02	PUPHC02 PUPHL02	
Drill capacity	[mm]	0.7 – 2.25	1.75 – 3.00	1.75 – 4.40	

- Self-drilling screw with reduced head height.
- This reduced head height gives it special characteristics:
 - Avoids interference with moving elements.
 - Aesthetic finish as screw is rounded and is concealed once installed.
 - May be used as a substitute for rivets.
 - Wide range of thicknesses to be drilled - from 0.70 mm to 4.40 mm.
 - Wide range of measurements.
 - Cone between thread and head to ensure piece sits perfectly.
 - Complete thread.
 - Annular groove at the bottom of the head which allows the material originated in the drilling process to stay in this area, allowing the screw to sit better.

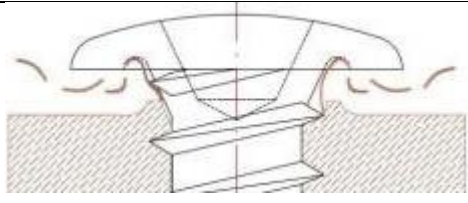
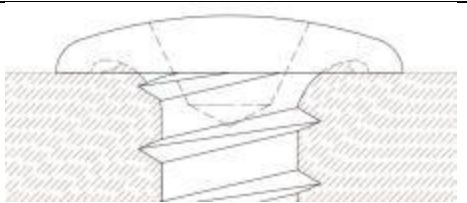
	
Drilling process, breaking shavings	Perfect piece finish

- Different views of the screw:



COLOURS

All self-drilling screws may be supplied painted in the following options (RAL colour scheme codes):

- **Head only or head and EPDM washer**

- White RAL 9010
- Pyrenean white RAL 9002
- Oyster white RAL 9018
- Bidasoa cream RAL 1000
- Sand RAL 1001
- Ivory RAL 1015
- Copper RAL 1007
- Tile red RAL 3011
- Coral red RAL 3003
- Burgundy RAL 3005
- Blue RAL 5009
- Lake blue RAL 5019
- Navarre green RAL 6028
- Light green RAL 6021
- Moss green RAL 6005
- Metallic grey RAL 9006
- Grey RAL 7035
- Black RAL 9005



Measurements: from 3.9x13 to 6.3x140.

Consult Sales Department for minimum quantity, price and delivery time.

- **Farmer Screw (FS) Colours:**

- Tile red RAL 3009
- Dark blue RAL 5010
- Olive green RAL 6005
- Light brown RAL 8004
- Dark brown RAL 8017
- Grey RAL 9006
- White RAL 9010
- Black RAL 9011



- **Fully painted**

- White RAL 9010
- Black RAL 9005
- Burgundy RAL 3005
- Moss green RAL 6005
- Blue RAL 5009



Measurements: from 2.9x6.5 to 5.5x 32. Minimum quantity: 15 kg

Consult Sales Department for price and delivery time.

- **ATAP Codes:** decorative plastic caps for 8 mm (ABE 4.8, ABE 5.5 and ARE) and 10 mm (ABE 6.3) hexagonal head screws.

- Pyrenean white RAL 9002
- Oyster white RAL 9018
- Sand RAL 1001
- Tile red RAL 3011
- Coral red RAL 3003
- Navarre green RAL 6028
- Black RAL 9005

