



ABE BIMETAL



AUTO BIMETAL



ABE BIMETAL + ARINOM



AUTO BIMETAL + ARINOM

CHARACTERISTICS

- Self-drilling stainless steel screw with tempered steel tip welded to the screw body, it allows drilling and screwing directly without previous drilling.
- It combines stainless steel properties (AISI 304/A2 head and body) with those of self-drilling screws (hardened steel tip), allowing its use as self-drilling screw with high corrosion protection.
- Atlantis C3-H covering, with high corrosion resistance, so screw tip is protected from corrosion in the highest aggressive conditions.
- Ideal where a combination of self-drilling and stainless steel properties are needed.
- Identical mechanical properties than self-drilling screws (ISO 10666).

BASE MATERIAL

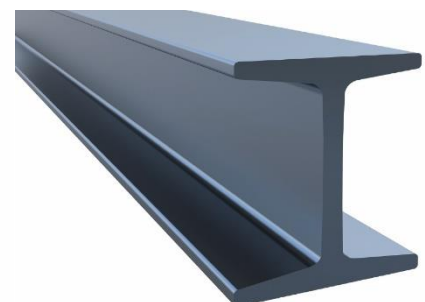

1. RANGE								
ITEM	CODE	SIZES	PHOTO	RECESS	HEAD	TIP	WASHER	COATING
1	BIE	From 4,8 x 25 till 6,3 x 25					--	
2	BIE16	From 4,8 x 25 till 6,3 x 25					P16	
3	BAUTO	From 5,5 x 40 till 5,5 x 100					--	
4	BAUTO16	From 5,5 x 40 till 5,5 x 100					P16	

2. MATERIALS					
ITEM	CODE	MATERIAL	SURFACE HARDNESS	CORE HARDNESS	HARDNESS DEPTH
1	BIE/BIE16	Head and body: AISI 304 Tip: tempered steel C1035	Head and body: -- Tip: > 500 HV	Head and body: -- Tip: 240 - 450 HV	Head and body: -- Tip: ST 4.8 – 5.5: 0.10 – 0.23 mm ST 6.3: 0.15 – 0.28 mm
2	BAUTO/BAUTO16	Head and body: AISI 304 Tip: tempered steel C1035	Head and body: -- Tip: > 500 HV	Head and body: -- Tip: 240 - 450 HV	Head and body: -- Tip: 5.5: 0.10 – 0.23 mm

3. INSTALACION PARAMETERS					
PARAMETERS			ST 4.8	ST 5.5	ST 6.3
Drilling speed	Stainless steel	[rpm]	1000 – 1500	600 - 1000	600 - 1000

4. MAXIMUM DRILLING THICKNESS				
CODE	BIE/BIE16			BAUTO/BAUTO16
DIAMETER	ST 4,8	ST 5,5	ST 6,3	ST 5,5
THICKNESS [mm]	1,75 – 4,40	1,75 – 5,25	2,50 – 6,00	4,00 – 12,00

5. MAXIMUM THICKNESS TO BE FIXED

THICKNESS [mm]				
SCREW LENGTH [mm]	BIE/BIE16			BAUTO/BAUTO16
	ST 4,8	ST 5,5	ST 6,3	ST 5,5
25	9	5	7	--
32	--	12	--	--
38	--	18	--	--
40	--	--	--	10
50	--	30	--	20
58	--	38	--	--
65	--	35	--	35
80	--	50	--	50
100	--	--	--	70

6. SCREW CHARACTERISTIC RESISTANCES

RESISTANCE [kN]				
SCREW DIAMETER [mm]	BIE/BIE16			BAUTO/BAUTO16
	ST 4,8	ST 5,5	ST 6,3	ST 5,5
TENSION	5,65	9,34	13,36	9,34
SHEAR	2,82	4,67	6,68	4,67

7. PRODUCT CHARACTERISTICS

7.1 BIE Two-metals stainless steel self-drilling screw



CHARACTERISTICS

- Two-metals stainless steel screw for drilling in steel
- Finished with Atlantis C3-H coating
- Common use for sheet-sheet joints
- Valid for drilling thicker profiles

MATERIALS & GEOMETRY

BASE MATERIAL

Two-metal	Atlantis C3-H	Hexagonal head	Stamped washer	Drill bit point	Sheet	Sheet – Beams

DIAMETER		ST 4.8	ST 5.5	ST 6.3
dk: Head washer diameter	[mm]	10,0	10,5	12,5
l: lengths	[mm]	25,0	25,0 – 80,0	25,0
k: head thickness	[mm]	4,3	5,3	6,3
d: outer thread diameter	[mm]	4,8	5,5	6,3
p: thread pitch	[mm]	1,6	1,8	1,8
s: wrench	[mm]	8	8	10
l _m : maximum thickness to be fixed	[mm]	9	l - 20	7
Drilling capacity	[mm]	1.75 – 4.40	1.75 – 5.25	2.50 – 6.00
Installation socket code (magnetic hexagonal socket)		BOCA008	BOCA008	BOCA010

PLANO

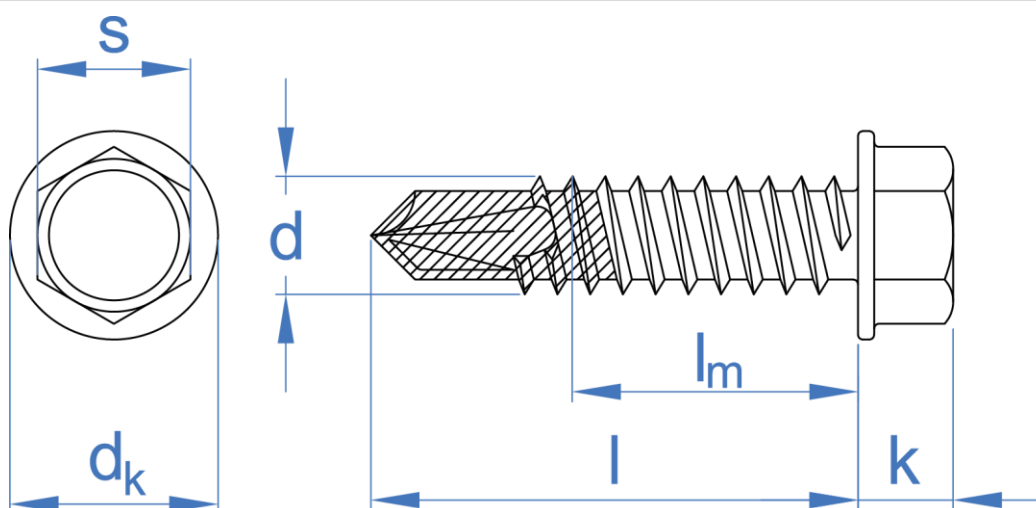

7.2 BIE16 Two-metals stainless steel self-drilling screw + ARINOM



CHARACTERISTICS

- Two-metals stainless steel screw for drilling in steel
- Finished with Atlantis C3-H coating
- Common use for sheet-sheet joints
- Valid for drilling thicker profiles
- Stainless steel washer

MATERIALS & GEOMETRY

BASE MATERIAL

Two-metal	Atlantis C3-H	Hexagonal head	Stamped washer	Drill bit point	Sheet	Sheet – Beams

DIAMETER		ST 4.8	ST 5.5	ST 6.3
dk: Head washer diameter	[mm]	10,0	10,5	12,5
l: lengths	[mm]	25,0	25,0 – 80,0	25,0
k: head thickness	[mm]	4,3	5,3	6,3
d: outer thread diameter	[mm]	4,8	5,5	6,3
p: thread pitch	[mm]	1,6	1,8	1,8
s: wrench	[mm]	8	8	10
l _m : maximum thickness to be fixed	[mm]	9	l - 20	7
Drilling capacity	[mm]	1.75 – 4.40	1.75 – 5.25	2.50 – 6.00
Installation socket code (magnetic hexagonal socket)		BOCA008	BOCA008	BOCA010
Washer size		P16	P16	P16

PLANO

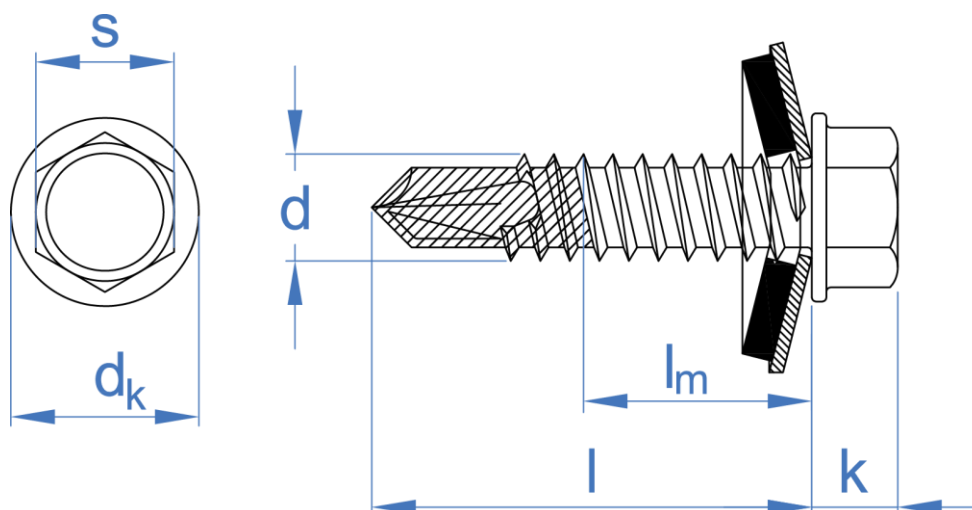

7.3 BAUTO Two-metals stainless steel self-drilling screw for beams



CHARACTERISTICS

- Two-metals stainless steel screw for drilling in steel
- Finished with Atlantis C3-H coating
- Common use for sheet-beam joints
- Valid for drilling IPN beams

MATERIALS & GEOMETRY

BASE MATERIAL

Two-metal	Atlantis C3-H	Hexagonal head	Stamped washer	Drill bit point	Sheet	Sheet – Beams	IPN Beam

DIAMETER

ST 5.5

dk: Head washer diameter	[mm]	10,5
l: lengths	[mm]	40,0 – 100,0
k: head thickness	[mm]	5,3
d: outer thread diameter	[mm]	5,5
p: thread pitch	[mm]	1,8
s: wrench	[mm]	8
lm: maximum thickness to be fixed	[mm]	l - 30
Drilling capacity	[mm]	4,00 - 12,00
Installation socket code (magnetic hexagonal socket)		BOCA008

PLANO

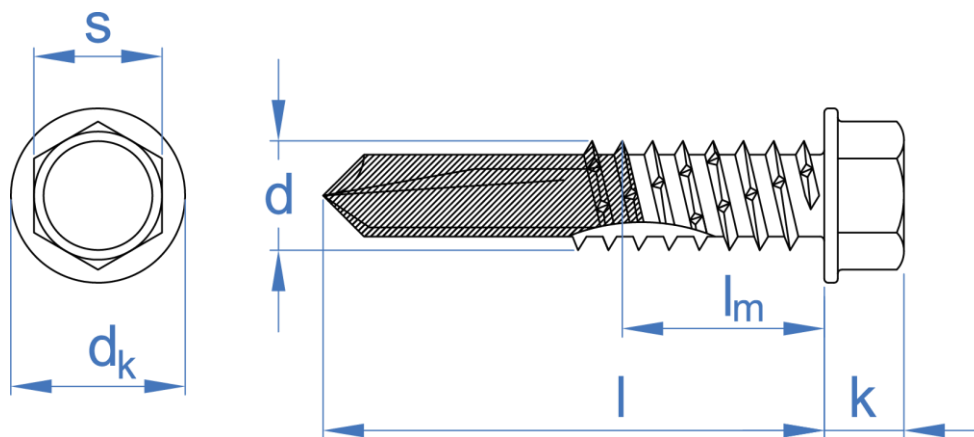

7.4 BAUTO16

Two-metals SS self-drilling screw for beams + ARINOM



CHARACTERISTICS

- Two-metals stainless steel screw for drilling in steel
- Finished with Atlantis C3-H coating
- Common use for sheet-beam joints
- Valid for drilling IPN beams
- Stainless steel washer

MATERIALS & GEOMETRY

BASE MATERIAL

Two-metal	Atlantis C3-H	Hexagonal head	Stamped washer	Drill bit point	Sheet	Sheet – Beams	IPN Beam

DIAMETER

ST 5.5

dk: Head washer diameter	[mm]	10,5
l: lengths	[mm]	40,0 – 100,0
k: head thickness	[mm]	5,3
d: outer thread diameter	[mm]	5,5
p: thread pitch	[mm]	1,8
s: wrench	[mm]	8
lm: maximum thickness to be fixed	[mm]	l - 30
Drilling capacity	[mm]	4,00 - 12,00
Installation socket code (magnetic hexagonal socket)		BOCA008
Washer size		P16

PLANO

