



**ZA-CA**



**ZA-PR**



**ZA-GA**



**ZA-TO**



**ZA-ES**



**ZA-AF**



**ZA-TL**



**ZA-AR**



**ZA-GF**

## CHARACTERISTICAS

- Wings and cone manufactured in zamak-5 by injection .
- Zinc plated coating
- Due to its higher cone expansion capacity, it is recommended in concrete as well as in lower resistance base materials (bricks, hollow bricks, low resistance concrete, etc.) which requires a higher expansion capacity
- Easy installation.
- Use for high loads
- Installation before the fixture

## APPLICATIONS

- Fixing of awnings, notices, urban fitting, etc.

## SIZES

**M6 – M16**

## DRILL HOLE CONDITION



**DRY**



**WET**



**FLOODED**

## BASE MATERIAL



## MAXIMUM LOADS RECOMMENDED IN NON-CRACKED CONCRETE [kg]

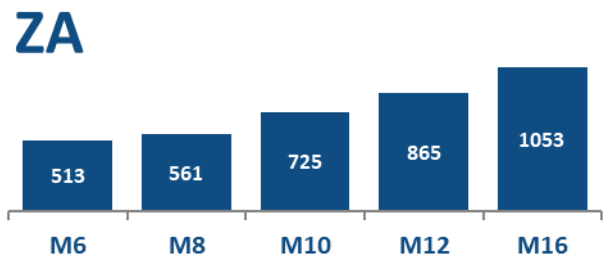

## APPLICATION EXAMPLES



1. RANGE						
ITEM	CODE	SIZE	PHOTO	COMPONENT	MATERIAL	COATING
1	AZAMCXX	M6 to M16		Capsule	Zamak 5, zinc-plated $\geq 5\mu\text{m}$	
2	AZAMTXX	M6 to M16		Capsule Bolt Washer	Zamak 5, zinc-plated $\geq 5\mu\text{m}$ Steel class 6.8, zinc-plated $\geq 5\mu\text{m}$ DIN 9021, zinc-plated $\geq 5\mu\text{m}$	
3	ZTXXLXX	M6 to M12		Capsule Bolt Washer	Zamak 5, zinc-plated $\geq 5\mu\text{m}$ Steel class 6.8, zinc-plated $\geq 5\mu\text{m}$ DIN 9021, zinc-plated $\geq 5\mu\text{m}$	
4	ZPXXCXX	M8 to M12		Capsule Bolt Washer Tube	Zamak 5, zinc-plated $\geq 5\mu\text{m}$ Steel class 6.8, zinc-plated $\geq 5\mu\text{m}$ DIN 9021, zinc-plated $\geq 5\mu\text{m}$ Tube EN 10305-2, zinc-plated $\geq 5\mu\text{m}$	
5	AZAMEXX	M6 to M16		Capsule Bolt Washer Nut	Zamak 5, zinc-plated $\geq 5\mu\text{m}$ Steel class 5.6, zinc-plated $\geq 5\mu\text{m}$ DIN 9021, zinc-plated $\geq 5\mu\text{m}$ DIN 934, zinc-plated $\geq 5\mu\text{m}$	
6	AZAMAXX	M6 to M12		Capsule Bolt Washer Nut	Zamak 5, zinc-plated $\geq 5\mu\text{m}$ Carbon steel, zinc-plated $\geq 5\mu\text{m}$ DIN 9021, zinc-plated $\geq 5\mu\text{m}$ DIN 934, zinc-plated $\geq 5\mu\text{m}$	
7	AZAMGXX	M6 to M12		Capsule Bolt Washer Nut	Zamak 5, zinc-plated $\geq 5\mu\text{m}$ Carbon steel, zinc-plated $\geq 5\mu\text{m}$ DIN 9021, zinc-plated $\geq 5\mu\text{m}$ DIN 934, zinc-plated $\geq 5\mu\text{m}$	
8	AZAMAFOXX	M6 to M12		Capsule Bolt Washer Nut	Zamak 5, zinc-plated $\geq 5\mu\text{m}$ Carbon steel, zinc-plated $\geq 5\mu\text{m}$ DIN 9021, zinc-plated $\geq 5\mu\text{m}$ DIN 934, zinc-plated $\geq 5\mu\text{m}$	
9	AZAMGFOXX	M6 to M12		Capsule Bolt Washer Nut	Zamak 5, zinc-plated $\geq 5\mu\text{m}$ Carbon steel, zinc-plated $\geq 5\mu\text{m}$ DIN 9021, zinc-plated $\geq 5\mu\text{m}$ DIN 934, zinc-plated $\geq 5\mu\text{m}$	

2. INSTALLATION DATA

2.1 DRAWING

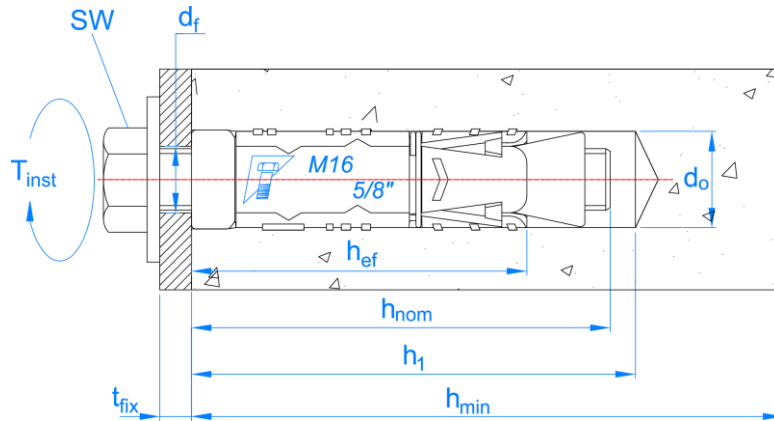

		M6	M8	M10	M12	M16
d <sub>0</sub> : drill bit diameter	[mm]	12	14	16	20	25
d <sub>2</sub> : washer diameter	[mm]	28	25	30	40	50
d <sub>f</sub> : fixture hole diameter	[mm]	7	9	12	14	18
d <sub>f, ZA-PR</sub> : fixture hole diameter, long loose bolt with pipe	[mm]	14	16	18	22	18
h <sub>nom</sub> : nominal depth	[mm]	48	50	58	72	107
h <sub>ef</sub> : effective depth	[mm]	41	43	51	61	96
h <sub>1</sub> : drill depth ≤	[mm]	60	65	75	90	125
h <sub>c</sub> : base material minimum thickness ≤	[mm]	100	100	102	122	192
s <sub>min</sub> : minimum spacing	[mm]	125	130	155	185	290
c <sub>min</sub> : minimum distance to edge	[mm]	65	65	80	95	145
t <sub>ins</sub> : installation torque	[Nm]	7	15	30	50	120
t <sub>fix</sub> : fixture thickness	[mm]	1	10	20	25	30
t <sub>fix, ZA-TL</sub> : fixture thickness long loose bolt	[mm]	10-30	15-45	10-80	15-65	--
t <sub>fix, ZA-PR</sub> : fixture thickness long loose bolt with pipe	[mm]	40	15-45	50-80	15-65	--
d <sub>3</sub> : inside diameter eye bolt/pressed eye bolt	[mm]	10/10	13/12	14/14	22/17	--
e: minimum hook opening/pressed eye bolt	[mm]	10/10	13/11	14/14	22/18	--
S <sub>w</sub> : nut wrench	[mm]	10	13	17	19	24

**3. INSTALLATION PROCEDURE**

**3.1. CONCRETE INSTALLATION**

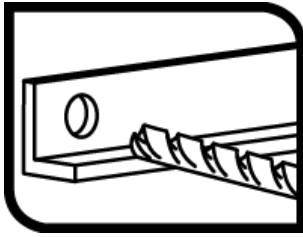

**1. DRILLING**

Check the concrete base is compact and porosity is insignificant.  
Suitable for wet, dry or flooded drill holes.

Use drill in hammer mode. In case of hollow materials do not use the hammer mode to prevent damages inside the base material. Reduce the speed when are about to finish the drill.

Drill to the specified diameter and depth values in previous table

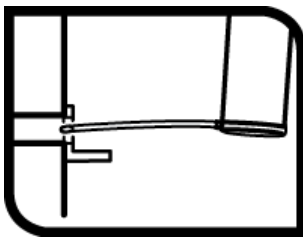

**2. BLOW AND CLEAN**

Clear the drill holes completely of dust and fragments.

Use air pump and brush.

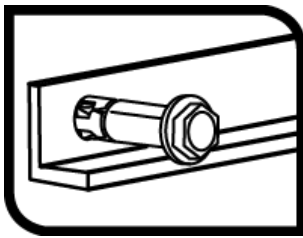

**3. INSTALL**

Insert the anchor in the hole until the red ring mark is flat with concrete surface.

Use hammer in case of need; DOMTA tool could be used alternatively.

The installation could be done through the fixture baseplate.

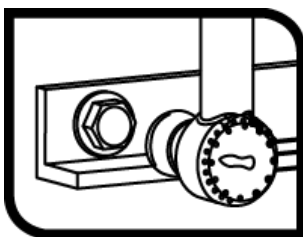

**4. APPLY THE TORQUE**

Apply nominal installation torque using a torque wrench.

## 4. RESISTANCES

Characteristic resistance in non-cracked concrete C20 / 25 for an isolated anchor (no effects edge distance or distances between anchors) is indicated in the following table

### 4.1 CHARACTERISTIC RESISTANCE [kN]

Family	Code	Sizes	Tension	Shear
			$N_{Rk}$	$V_{Rk}$
ZA-CA	AZAMC06	M6 x 48 Ø12	12,69	<u>6,03</u>
	AZAMC08	M8 x 50 Ø14	<b>13,87</b>	<u>10,98</u>
	AZAMC10	M10 x 58 Ø16	<b>17,92</b>	<b>17,92</b>
	AZAMC12	M12 x 72 Ø20	21,38	<u>25,29</u>
	AZAMC16	M16 x 107 Ø25	26,03	<u>47,10</u>
ZA-TO	AZAMT06	M6 x 50 Ø12	12,69	<u>6,03</u>
	AZAMT08	M8 x 60 Ø14	<b>13,87</b>	<u>10,98</u>
	AZAMT10	M10 x 80 Ø16	<b>17,92</b>	<b>17,92</b>
	AZAMT12	M12 x 100 Ø20	21,38	<u>25,29</u>
	AZAMT16	M16 x 140 Ø25	26,03	<u>47,10</u>
ZA-TL	ZT06L10	M6 x 60 Ø12	12,69	<u>6,03</u>
	ZT06L30	M6 x 80 Ø12		
	ZT08L15	M8 x 70 Ø14		
	ZT08L35	M8 x 90 Ø14	<b>13,87</b>	<u>10,98</u>
	ZT08L45	M8 x 100 Ø14		
	ZT10L10	M10 x 70 Ø16	<b>17,92</b>	<b>17,92</b>
	ZT10L30	M10 x 90 Ø16		
	ZT10L50	M10 x 110 Ø16		
	ZT10L80	M10 x 140 Ø16		
	ZT12L15	M12 x 90 Ø20	21,38	<u>25,29</u>
ZT12L45	M12 x 120 Ø20			
ZT12L65	M12 x 140 Ø20			
ZA-PR	ZP08C15	M8 x 70 Ø14	<b>13,87</b>	<u>10,98</u>
	ZP08C45	M8 x 100 Ø14		
	ZP10C50	M10 x 110 Ø16	<b>17,92</b>	<b>17,92</b>
	ZP12C15	M12 x 120 Ø20	21,38	<u>25,29</u>
ZA-ES	AZAME06	M6 x 60 Ø12	<u>8,44</u>	<u>4,22</u>
	AZAME08	M8 x 70 Ø14	<b>13,87</b>	<u>7,69</u>
	AZAME10	M10 x 100 Ø16	<b>17,92</b>	<u>12,18</u>
	AZAME12	M12 x 120 Ø20	21,38	<u>17,70</u>
	AZAME16	M16 x 140 Ø25	26,03	<u>32,97</u>
ZA-AR	AZAMA06	M6 x 45 Ø12	<u>1,50</u>	-
	AZAMA08	M8 x 50 Ø14	<u>3,00</u>	-
	AZAMA10	M10 x 56 Ø16	<u>5,00</u>	-
	AZAMA12	M12 x 70 Ø20	<u>6,00</u>	-
ZA-GA	AZAMG06	M6 x 45 Ø12	<u>1,50</u>	-
	AZAMG08	M8 x 50 Ø14	<u>3,00</u>	-
	AZAMG10	M10 x 56 Ø16	<u>5,00</u>	-
	AZAMG12	M12 x 70 Ø20	<u>6,00</u>	-
ZA-AF	AZAMAFO06	M6 x 45 Ø12	<u>4,21</u>	-
	AZAMAFO08	M8 x 50 Ø14	<u>11,43</u>	-
	AZAMAFO10	M10 x 56 Ø16	<b>17,92</b>	-
	AZAMAFO12	M12 x 70 Ø20	<u>16,89</u>	-
ZA-GF	AZAMGFO06	M6 x 45 Ø12	<u>1,64</u>	-
	AZAMGFO08	M8 x 50 Ø14	<u>3,19</u>	-
	AZAMGFO10	M10 x 56 Ø16	<u>5,00</u>	-
	AZAMGFO12	M12 x 70 Ø20	<u>8,16</u>	-

1 kN ≈ 100 kg

Values underlined and in italics show steel failure, **bold** values concrete failure and other indicate pull out failure.

4.2 DESIGN RESISTANCE [kN]				
Family	Code	Sizes	Tension	Shear
			$N_{Rk}$	$V_{Rk}$
ZA-CA	AZAMC06	M6 x 48 Ø12	7,05	<u>4,82</u>
	AZAMC08	M8 x 50 Ø14	<b>7,71</b>	<u>8,78</u>
	AZAMC10	M10 x 58 Ø16	<b>9,95</b>	<b>11,94</b>
	AZAMC12	M12 x 72 Ø20	11,88	<u>20,23</u>
	AZAMC16	M16 x 107 Ø25	14,46	<u>37,68</u>
ZA-TO	AZAMT06	M6 x 50 Ø12	7,05	<u>4,82</u>
	AZAMT08	M8 x 60 Ø14	<b>7,71</b>	<u>8,78</u>
	AZAMT10	M10 x 80 Ø16	<b>9,95</b>	<b>11,94</b>
	AZAMT12	M12 x 100 Ø20	11,88	<u>20,23</u>
	AZAMT16	M16 x 140 Ø25	14,46	<u>37,68</u>
ZA-TL	ZT06L10	M6 x 60 Ø12	7,05	<u>4,82</u>
	ZT06L30	M6 x 80 Ø12		
	ZT08L15	M8 x 70 Ø14	<b>7,71</b>	<u>8,78</u>
	ZT08L35	M8 x 90 Ø14		
	ZT08L45	M8 x 100 Ø14		
	ZT10L10	M10 x 70 Ø16	<b>9,95</b>	<b>11,94</b>
	ZT10L30	M10 x 90 Ø16		
	ZT10L50	M10 x 110 Ø16		
	ZT10L80	M10 x 140 Ø16		
	ZT12L15	M12 x 90 Ø20	11,88	<u>20,23</u>
ZT12L45	M12 x 120 Ø20			
ZT12L65	M12 x 140 Ø20			
ZA-PR	ZP08C15	M8 x 70 Ø14	<b>7,71</b>	<u>8,78</u>
	ZP08C45	M8 x 100 Ø14		
	ZP10C50	M10 x 110 Ø16	<b>9,95</b>	<b>11,94</b>
	ZP12C15	M12 x 120 Ø20	11,88	<u>20,23</u>
ZA-ES	AZAME06	M6 x 60 Ø12	<u>5,70</u>	<u>3,38</u>
	AZAME08	M8 x 70 Ø14	<b>7,71</b>	<u>6,15</u>
	AZAME10	M10 x 100 Ø16	<b>9,95</b>	<u>9,74</u>
	AZAME12	M12 x 120 Ø20	11,88	<u>14,16</u>
	AZAME16	M16 x 140 Ø25	14,46	<u>26,38</u>
ZA-AR	AZAMA06	M6 x 45 Ø12	<u>1,00</u>	-
	AZAMA08	M8 x 50 Ø14	<u>2,00</u>	-
	AZAMA10	M10 x 56 Ø16	<u>3,33</u>	-
	AZAMA12	M12 x 70 Ø20	<u>4,00</u>	-
ZA-GA	AZAMG06	M6 x 45 Ø12	<u>1,00</u>	-
	AZAMG08	M8 x 50 Ø14	<u>2,00</u>	-
	AZAMG10	M10 x 56 Ø16	<u>3,33</u>	-
	AZAMG12	M12 x 70 Ø20	<u>4,00</u>	-
ZA-AF	AZAMAFO06	M6 x 45 Ø12	<u>2,81</u>	-
	AZAMAFO08	M8 x 50 Ø14	<u>7,62</u>	-
	AZAMAFO10	M10 x 56 Ø16	<b>9,95</b>	-
	AZAMAFO12	M12 x 70 Ø20	<u>11,26</u>	-
ZA-GF	AZAMGFO06	M6 x 45 Ø12	<u>1,06</u>	-
	AZAMGFO08	M8 x 50 Ø14	<u>2,13</u>	-
	AZAMGFO10	M10 x 56 Ø16	<u>3,33</u>	-
	AZAMGFO12	M12 x 70 Ø20	<u>5,44</u>	-

1 kN ≈ 100 kg  
 Values underlined and in italics show steel failure, **bold** values concrete failure and other indicate pull out failure.

## 4.3 MAXIMUM LOAD RECOMMENDED [kN]

Family	Code	Size	Tension	Shear
			$N_{Rk}$	$V_{Rk}$
ZA-CA	AZAMC06	M6 x 48 Ø12	5,04	<u>3,45</u>
	AZAMC08	M8 x 50 Ø14	<b>5,50</b>	<u>6,27</u>
	AZAMC10	M10 x 58 Ø16	<b>7,11</b>	<b>8,53</b>
	AZAMC12	M12 x 72 Ø20	8,48	<u>14,45</u>
	AZAMC16	M16 x 107 Ø25	10,33	<u>26,91</u>
ZA-TO	AZAMT06	M6 x 50 Ø12	5,04	<u>3,45</u>
	AZAMT08	M8 x 60 Ø14	<b>5,50</b>	<u>6,27</u>
	AZAMT10	M10 x 80 Ø16	<b>7,11</b>	<b>8,53</b>
	AZAMT12	M12 x 100 Ø20	8,48	<u>14,45</u>
	AZAMT16	M16 x 140 Ø25	10,33	<u>26,91</u>
ZA-TL	ZT06L10	M6 x 60 Ø12	5,04	<u>3,45</u>
	ZT06L30	M6 x 80 Ø12		
	ZT08L15	M8 x 70 Ø14	<b>5,50</b>	<u>6,27</u>
	ZT08L35	M8 x 90 Ø14		
	ZT08L45	M8 x 100 Ø14		
	ZT10L10	M10 x 70 Ø16	<b>7,11</b>	<b>8,53</b>
	ZT10L30	M10 x 90 Ø16		
	ZT10L50	M10 x 110 Ø16		
	ZT10L80	M10 x 140 Ø16		
	ZT12L15	M12 x 90 Ø20	8,48	<u>14,45</u>
ZT12L45	M12 x 120 Ø20			
ZT12L65	M12 x 140 Ø20			
ZA-PR	ZP08C15	M8 x 70 Ø14	<b>5,50</b>	<u>6,27</u>
	ZP08C45	M8 x 100 Ø14		
	ZP10C50	M10 x 110 Ø16	<b>7,11</b>	<b>8,53</b>
	ZP12C15	M12 x 120 Ø20	8,48	<u>14,45</u>
ZA-ES	AZAME06	M6 x 60 Ø12	<u>4,07</u>	<u>2,41</u>
	AZAME08	M8 x 70 Ø14	<b>5,50</b>	<u>4,39</u>
	AZAME10	M10 x 100 Ø16	<b>7,11</b>	<u>6,96</u>
	AZAME12	M12 x 120 Ø20	8,48	<u>10,12</u>
	AZAME16	M16 x 140 Ø25	10,33	<u>18,48</u>
ZA-AR	AZAMA06	M6 x 45 Ø12	<u>0,71</u>	-
	AZAMA08	M8 x 50 Ø14	<u>1,43</u>	-
	AZAMA10	M10 x 56 Ø16	<u>2,38</u>	-
	AZAMA12	M12 x 70 Ø20	<u>2,86</u>	-
ZA-GA	AZAMG06	M6 x 45 Ø12	<u>0,71</u>	-
	AZAMG08	M8 x 50 Ø14	<u>1,43</u>	-
	AZAMG10	M10 x 56 Ø16	<u>2,38</u>	-
	AZAMG12	M12 x 70 Ø20	<u>2,86</u>	-
ZA-AF	AZAMAFO06	M6 x 45 Ø12	<u>2,00</u>	-
	AZAMAFO08	M8 x 50 Ø14	<u>5,44</u>	-
	AZAMAFO10	M10 x 56 Ø16	<b>7,11</b>	-
	AZAMAFO12	M12 x 70 Ø20	<u>8,04</u>	-
ZA-GF	AZAMGFO06	M6 x 45 Ø12	<u>0,78</u>	-
	AZAMGFO08	M8 x 50 Ø14	<u>1,52</u>	-
	AZAMGFO10	M10 x 56 Ø16	<u>2,38</u>	-
	AZAMGFO12	M12 x 70 Ø20	<u>3,89</u>	-

1 kN ≈ 100 kg

Values underlined and in italics show steel failure, **bold** values concrete failure and other indicate pull out failure.