

## ST-PSC

## SYSTEM DESCRIPTION

Triangular mounting system with PSE-C “aluminium profile for assembled fixing”, for the installation of solar panels.

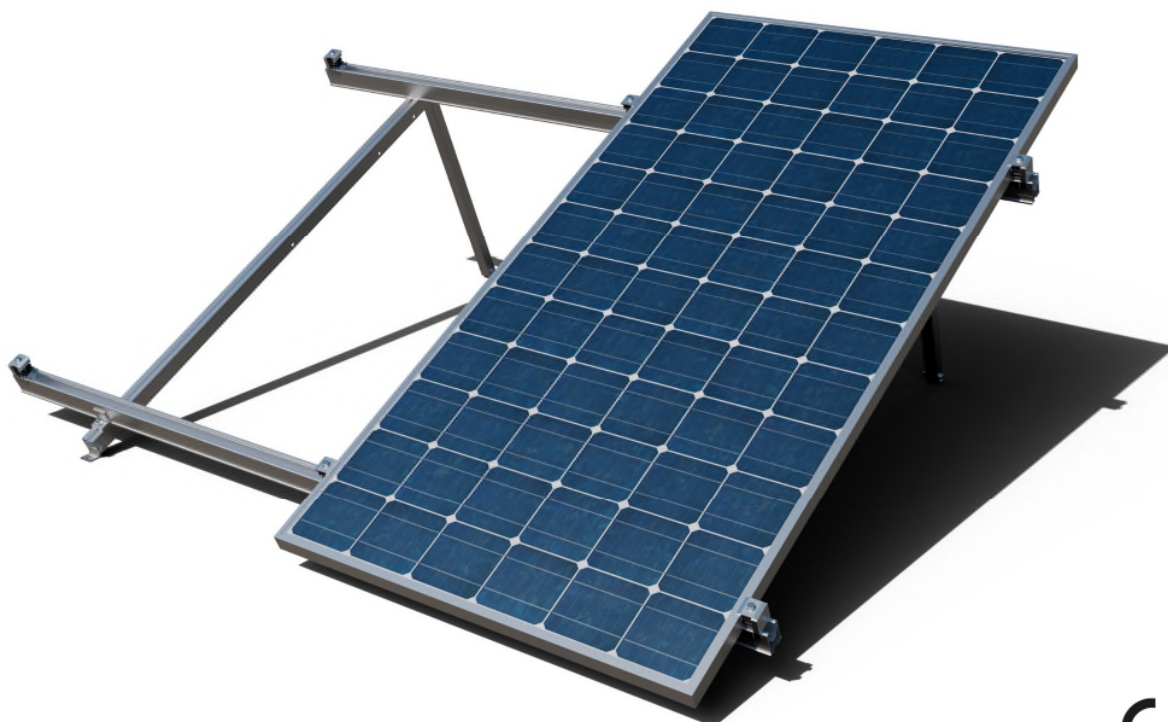

## 1. CHARACTERISTICS

<b>Description</b>	Triangular mounting system on PSE-C aluminium profile in continuous format on concrete.
<b>System inclination:</b>	Triangular mounting on pre-assembled triangles with adjustable inclination at 25°, 30° and 35°.
<b>System orientation:</b>	Facing SOUTH, EAST OR WEST depending on the roof orientation.
<b>System materials:</b>	Aluminium, stainless Steel and EPDM.
<b>Warranty:</b>	Until 10 years depending on environmental conditions (excluding environments exposed to hydrogen sulphide). The warranty is only valid if the complete ST-PSC system is used.
<b>Certification:</b>	CE according to EN 1090-1:2009+A1:2011
<b>Compatible solar panels:</b>	
<b>Solar panels type:</b>	Solar panels with frame height between 30mm and 40mm.
<b>Solar panels orientation:</b>	Mounting orientation of portrait (vertical)
<b>Solar panel size</b>	Panel length less than 1150 mm
<b>Application area:</b>	
<b>Application area:</b>	Flat and low-slope roofs.
<b>Roof slope:</b>	Up to 240 km/h. The structure and fixing must be calculated according to local and roof conditions.
<b>Wind load:</b>	Up to 2 kN/m <sup>2</sup> . The structure and fixing must be calculated according to local and roof conditions.

## 2. COMPONENTS

Quick pre-assembled clamp		Simple clamp		INDEXTRUT quick nut		Gauge for solar frame		Pe Profile for assembled fixing		Connector for PSE-C profile		Pre-assembled and adjustable aluminium triangle		Cross connector for bottom fixing		Cross connector for lateral fixing	
	KFR-SC		PGS-A		TU-RXA2		GM-A		PSE-C		PSE-CUN		TPA-R		KFS-FI		KFS-FC

### 2.1 Components: Clamps y gauges for mounting solar panels

Lateral position clamp		Intermediate position clamp	
Option 1: Quick clamp	Option 2: Simple clamp	Option 1: Quick clamp	Option 2: Simple clamp

### 2.2 Components: Profiles, joints and guides for supporting structures

Longitudinal connection of profiles	Profile connection to the adjustable triangle

### 2.3 Components: mounting connectors for fixing accessories

Lower connection
Fixing with concrete screws

### 3. TYPES OF FIXINGS

TYPE 1	 CONCRETE			 THE Concrete screw anchor		
--------	---	--	--	--	--	--

### 4. EXAMPLES OF APPLICATION

Example 1: Concrete cover / direct fixing in concrete with THE screws

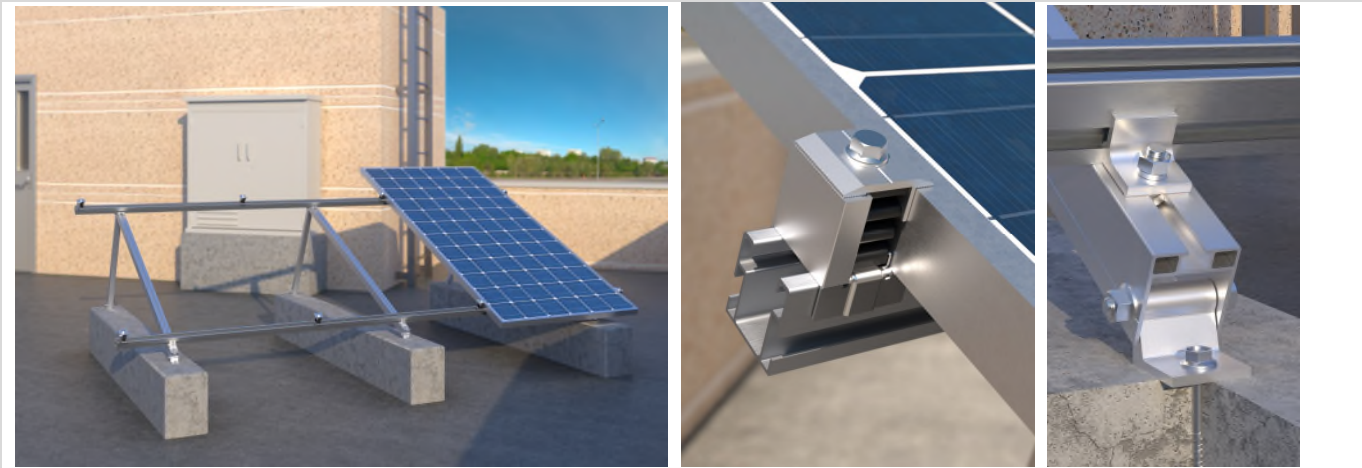

## 5. INSTALLATION MANUAL

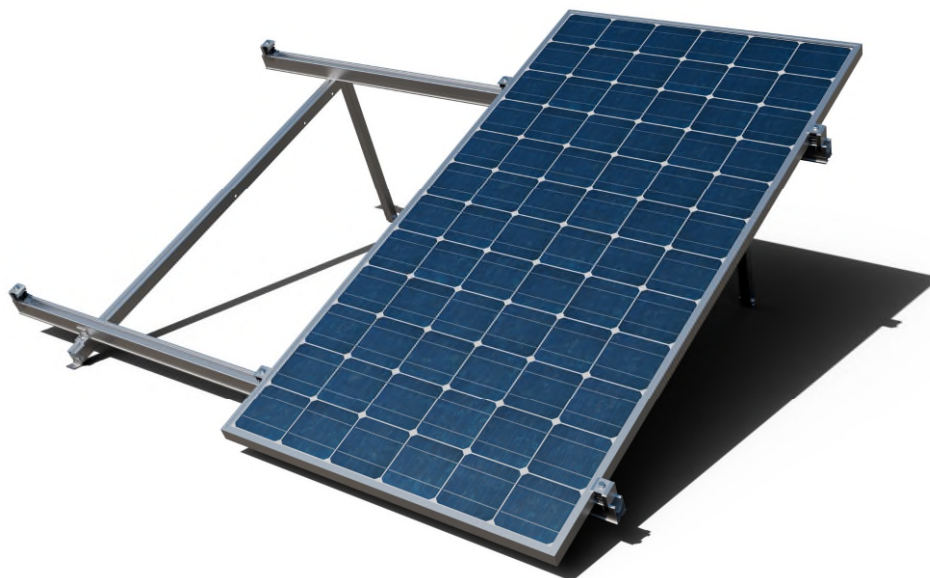
**ST-PSC****Triangular mounting system with PSE-C  
“aluminium profile for assembled fixing” fixing on  
concrete**

Read these installation instructions before starting installation and familiarise yourself with the system components. Installation must only be carried out by qualified and experienced personnel.

**Installation guidelines:**

- Ensure that the roof construction is suitable for the introduction of forces at the fixing points and their subsequent transmission. The building must be able to safely receive the additional loads.
- A structural calculation must be carried out based on the local conditions at the installation site.
- The planning of the layout of the fixing points must be adapted to the requirements of the system and the roof.
- To compensate for thermal expansion, include a spacing every 12m when planning the PV system.
- The solar modules must be installed according to the manufacturer's instructions.
- Follow your local building regulations.
- Make sure to work in accordance with the health and safety regulations in force in your region, during installation and during roof work.
- Do not use the system or fixings as stairs.

## INSTALLATION PROCESS:

### STEP 1.- Consult installation drawing

Consult the installation drawing on the roof, where the distribution of the modules is defined as well as the structures that support them and their fixing points.

- A. Plan view of ST-PSC system with vertical module orientation (portrait type).

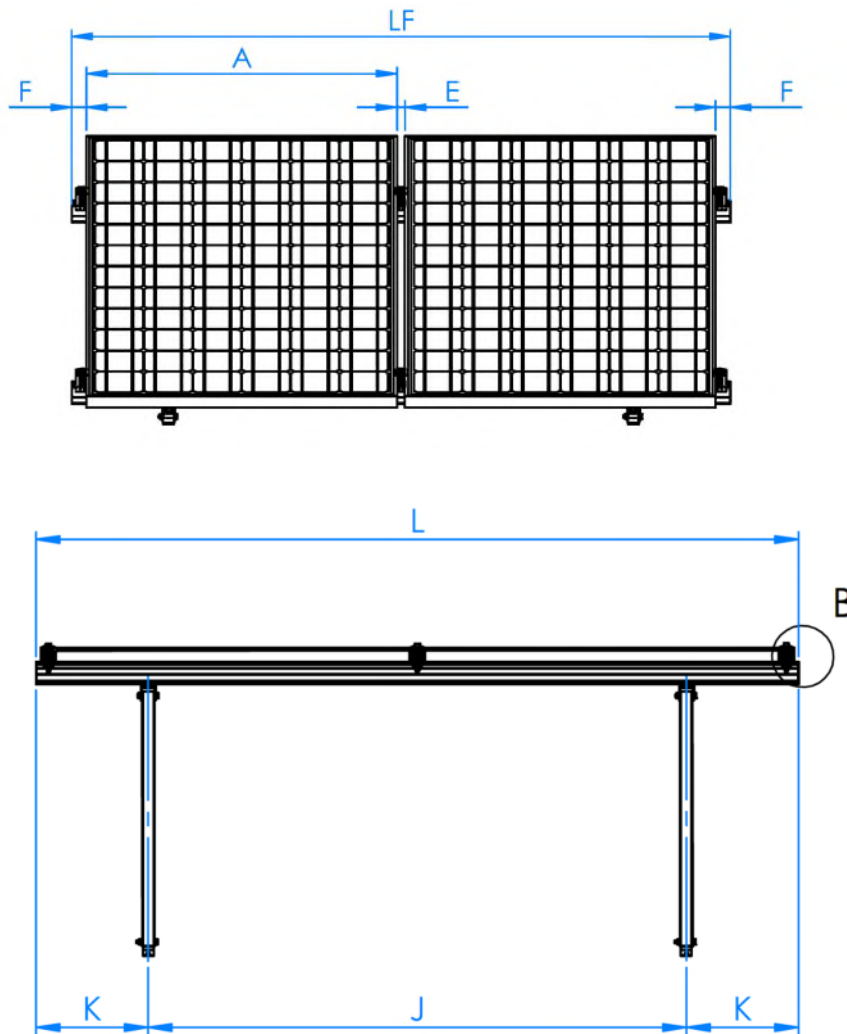

A (mm)	E (mm)	F (mm)	J (mm)	K (mm)	LF
≤ 1150	26	≥ 35	1400 ÷ 1600	(LF-J) / 2	(n*B) + ((n-1) *E) + (2*F)
n: number of modules in the row.					

**B. ST-PSC system profile view**

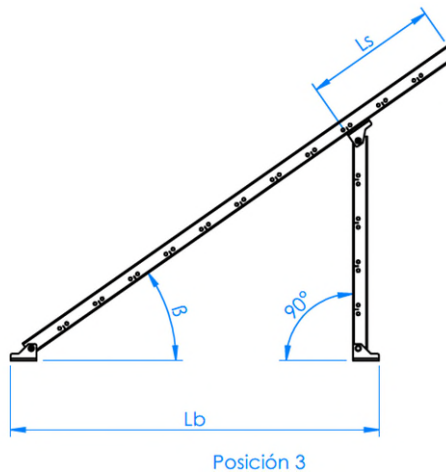
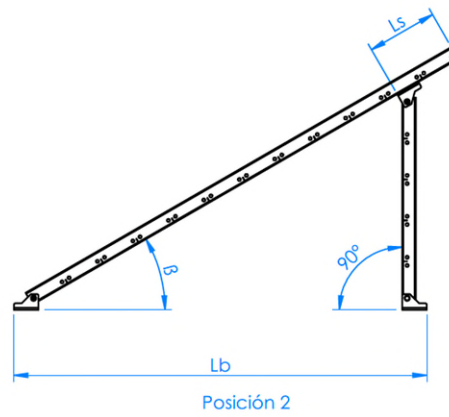
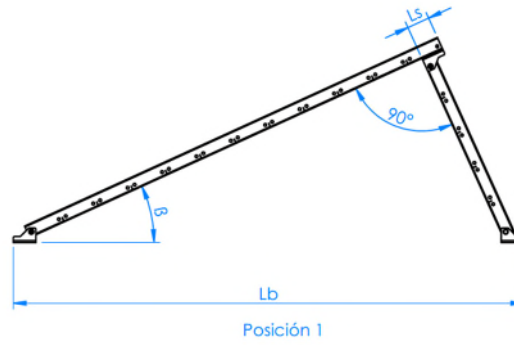

Position 1			Position 2			Position 3		
$\beta$ (°C)	Ls (mm)	Lb (mm)	$\beta$ (°C)	Ls (mm)	Lb (mm)	$\beta$ (°C)	Ls (mm)	Lb (mm)
25	18	1696	30	118	1260	35	293	1052

The type of fixing system and the location of its installation points shall be adapted to the needs of the supporting structures and at the same time to the needs of the roofs where they must be installed.

## STEP 2.- Perform layout on the roof

Lay out on the roof the fixing points of each structure, checking the viability of the installation of each one depending on the chosen fixing system and the characteristics of the roof.

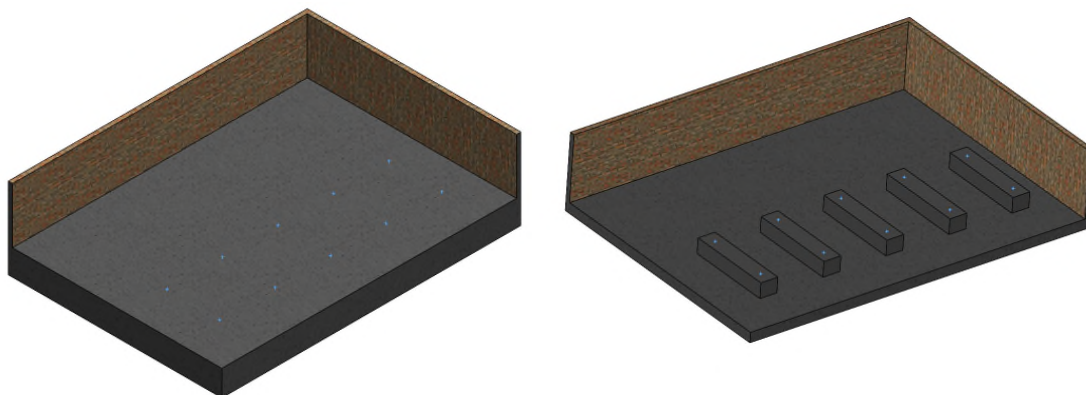

## STEP 3.- Installation of the triangles

Install the adjustable aluminium triangles and fix them on the deck at the agreed points with the help of the THE concrete screw. For the installation of THE screws an electric screwdriver equipped with hexagon socket SW-10 is required, an installation speed of 1800 rpm is recommended.

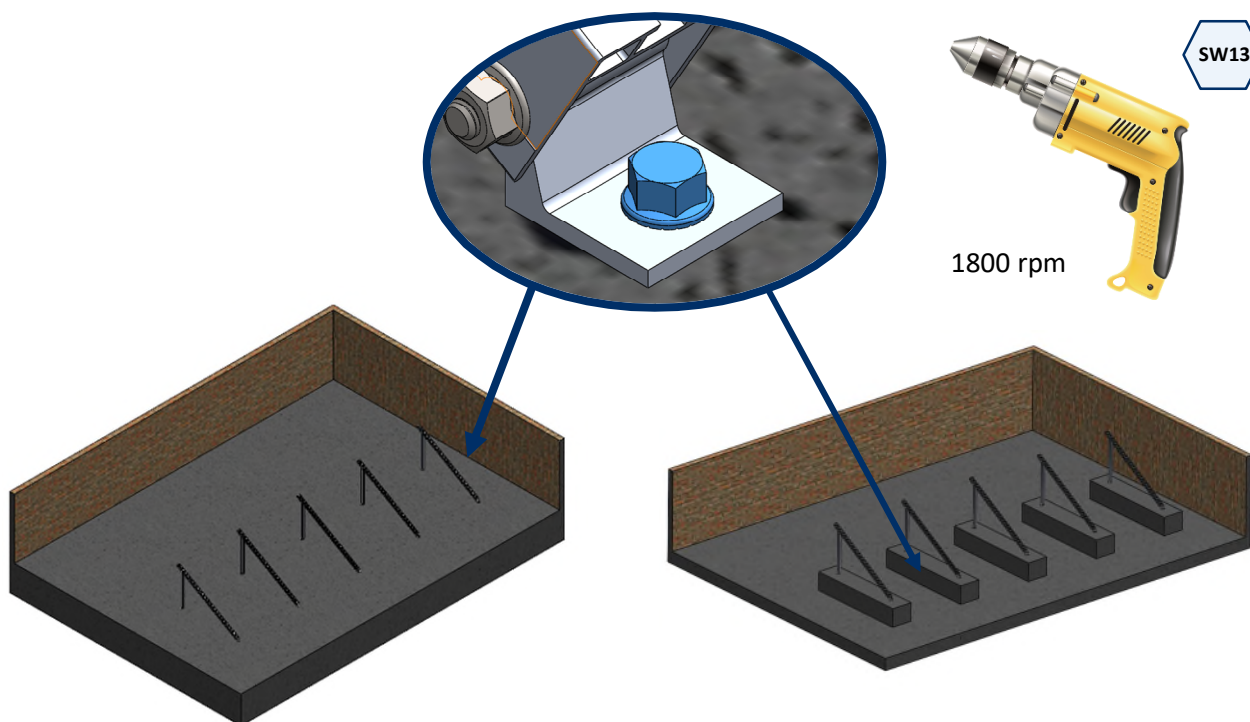

**THE**  
Concrete screw anchor  
[Technical Data Sheet](#)

**STEP 4.- Installation of the profiles on the triangles**

- A.** Position the PSE-C aluminium profiles in the correct position for the installation of the panels.

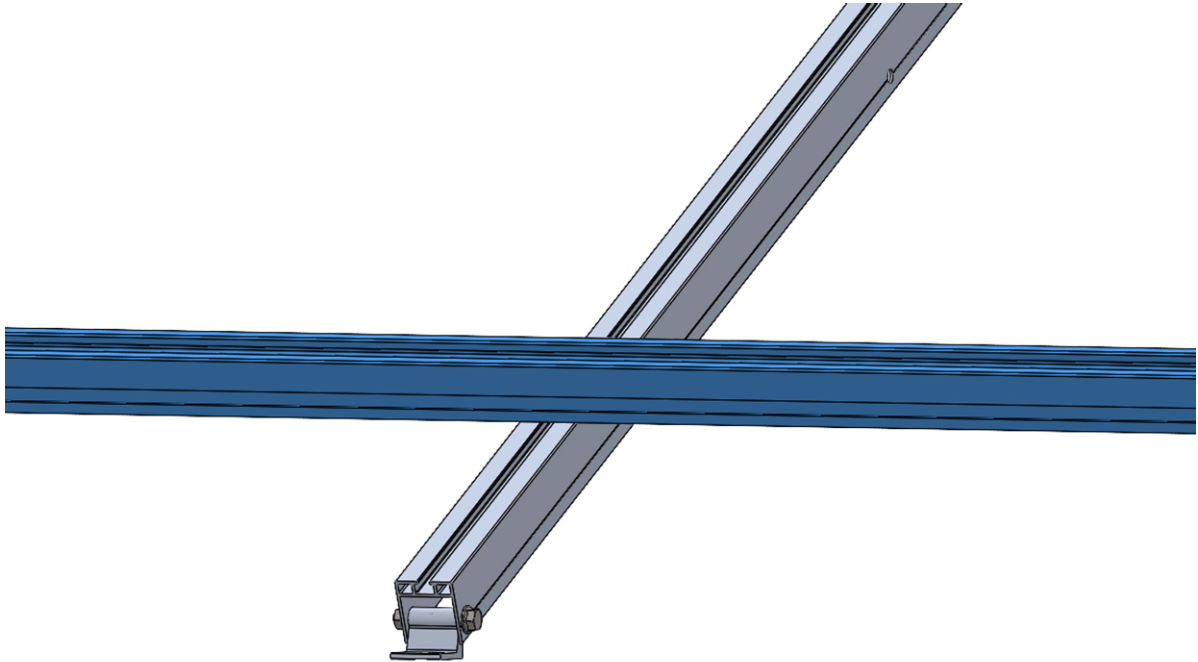

- B.** Secure the position using the KFS-FC connector, two of them, one on each side of the PSE-C profile. Tighten to a maximum torque of 15 Nm using a SW-13 hexagon spanner. The KFS-FC connector has a notch on the rear side to aid assembly and coupling to the PSE-C profile.

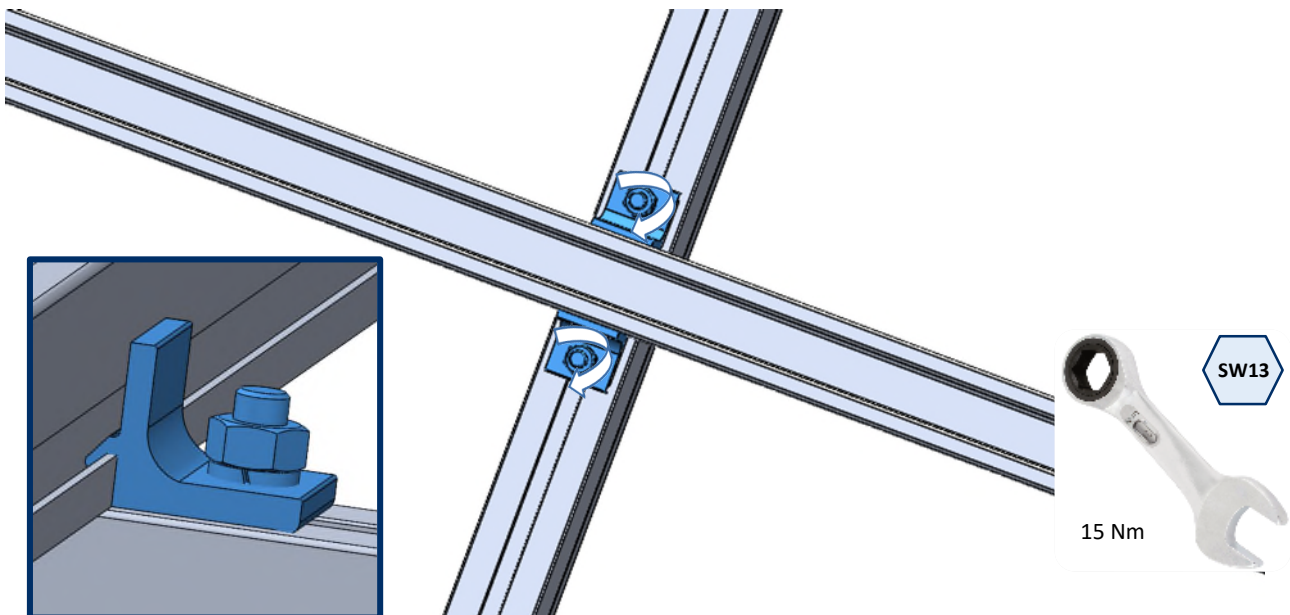



**STEP 5.- Longitudinal connection between profiles**

- A.** Assemble the PSE-CUN joint by inserting half of the length into one of the two PSE-C profiles.

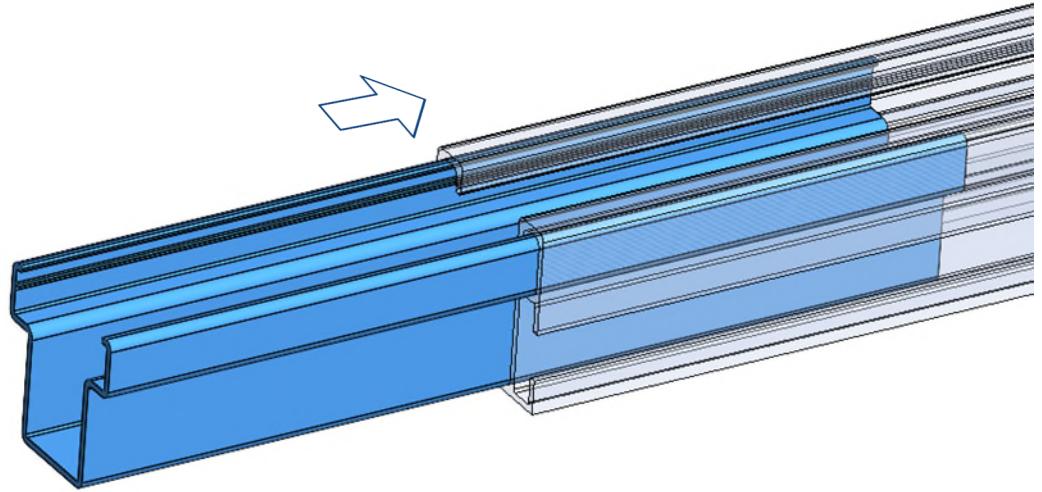

- B.** Fix the PSE-CUN joint to the first PSE-C profile by installing 2 self-drilling stainless steel screws ABEI5519. The screws must be installed in the lower part of the profile, at a distance between 50 and 70mm from the end of the profile. For the installation of the ABEI5519 screws an electric screwdriver equipped with hexagon socket SW-8 is required, an installation speed of 1800 rpm is recommended.

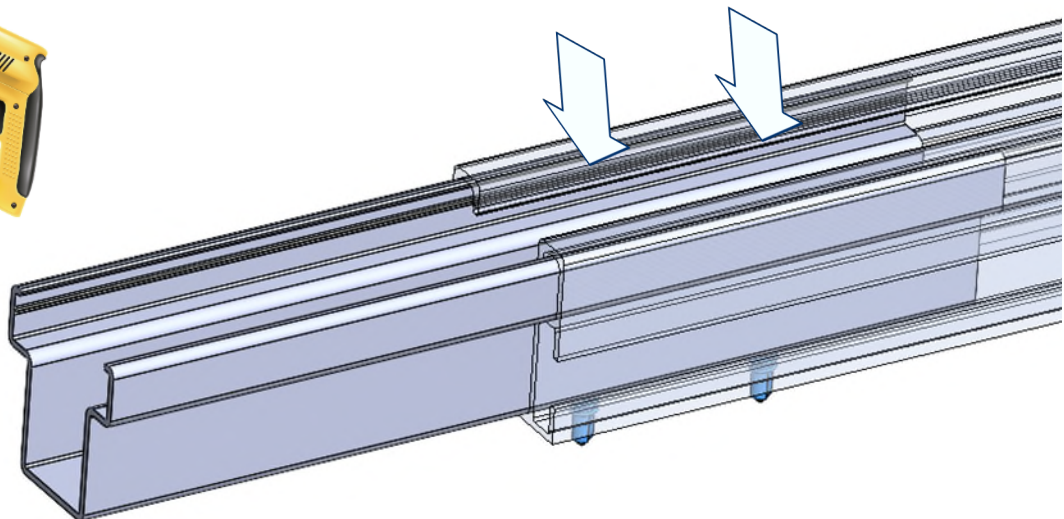

C. Insert the free end of the PSE-CUN connector into the second PSE-C profile.

- **Option 1**, if a rigid connection is required: Insert the protruding part of the PSE-CUN connection into the second PSE-C profile until it butts against the first profile, and then fix the connection to this second profile by installing 2 self-drilling stainless steel screw ABEI5519, as previously carried out on the first profile.

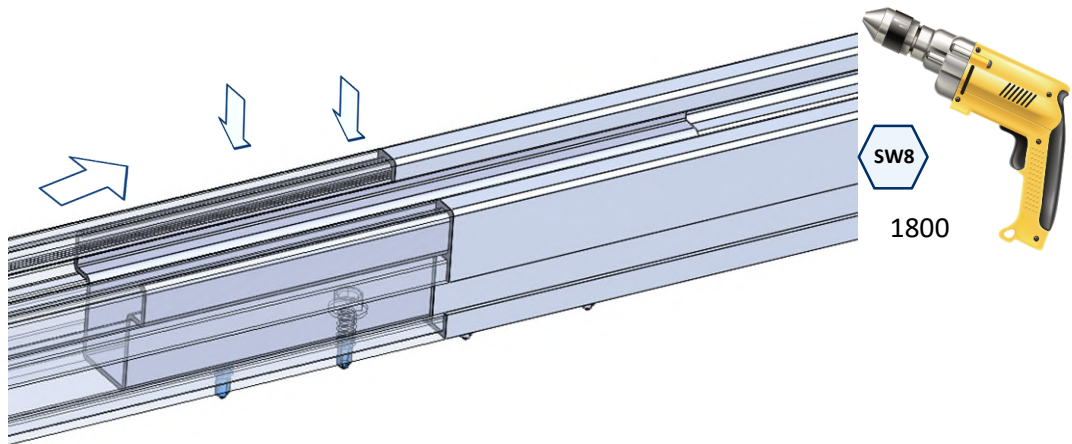

- **Option 2**, If a connection acting as an expansion joint is required: Insert the protruding part of the PSE-C joint PSE-CUN into the second PSE-C profile, leaving a gap between the ends of the two profiles of between 4 and 6 mm, in this case the screws are not installed to allow longitudinal displacements between the two profiles.

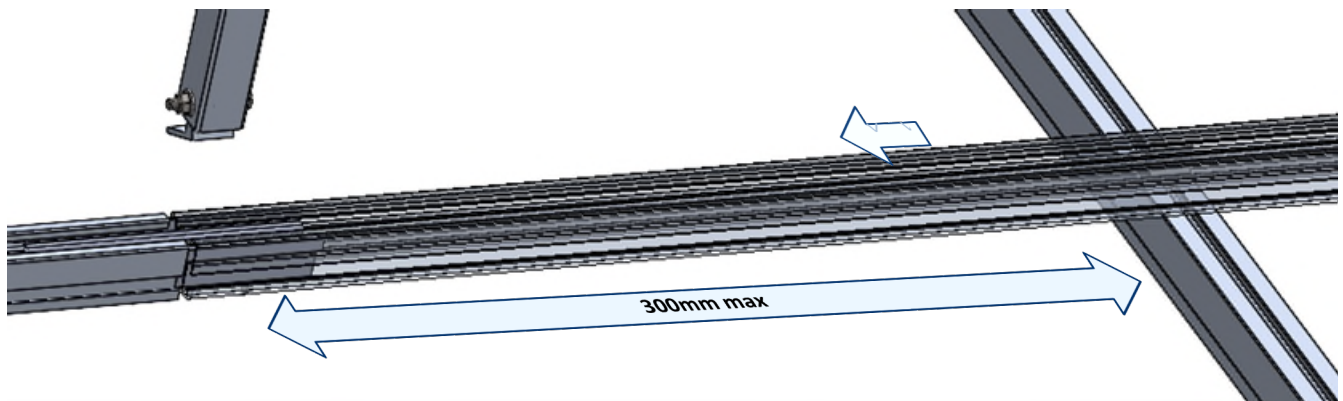

Is recommended for this type of connection a maximum distance to the nearest fixing point of 300 mm

## STEP 6.- Pre-installation of clamps on the profiles

To mount the clamp on the profiles, the following steps are necessary:

<p><b>1.</b> Place the clamp in the profile with the lower nut parallel to the profile.</p>	<p><b>2.</b> To fix the clamp to the profile, the lower nut must be turned perpendicular to the profile by means of the screw, the screw head is pressed down and turned. The nut has a serrated rail to secure the fixing.</p>	<p><b>3.</b> Insert the corresponding elements, two panels in the case of an intermediate clamp, or a panel and a gauge in the case of a lateral clamp.</p>	<p><b>4.</b> To fix the inserted elements it is necessary to turn the screw until they meet the profile. Check that the lower nut remains perpendicular to the profile.</p>

Type of clamp depending on its position:

### A. Intermediate clamp

- The intermediate clamp is used when passing from one module to another within the same row, fixing both panels to the structure. This assembly is carried out by means of the screw included in the clamp. A tightening torque of 14 Nm must be applied.

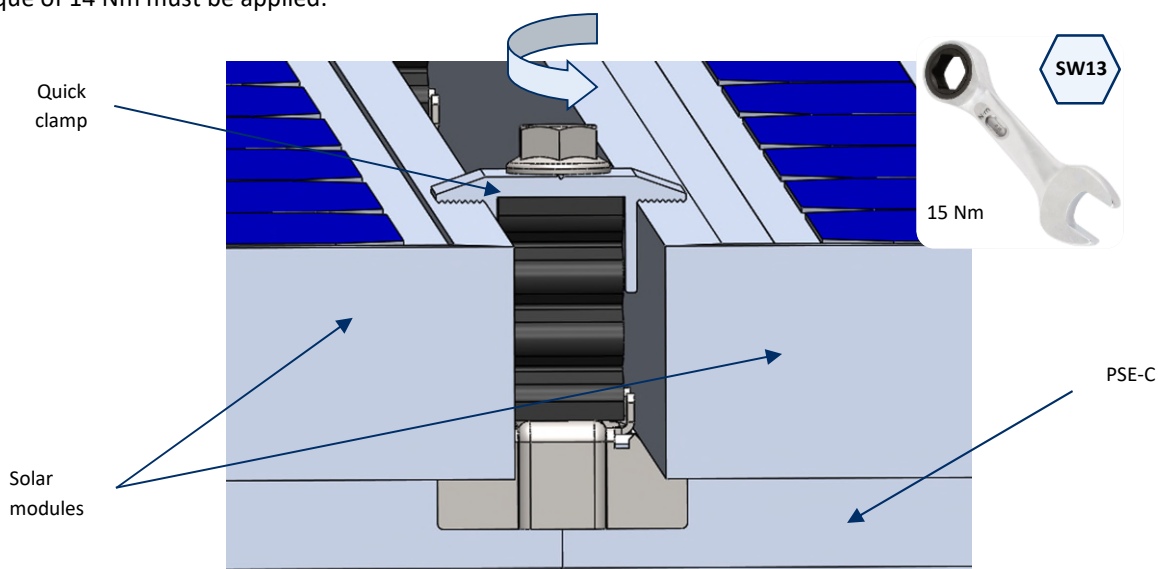

**B. Lateral clamp**

- Prepare 4 KFRSC3050 quick fixing clamps to be mounted at the ends of each row of panels. Each of these clamps is fitted with a GM-A gauge, mounted as shown in the figure:

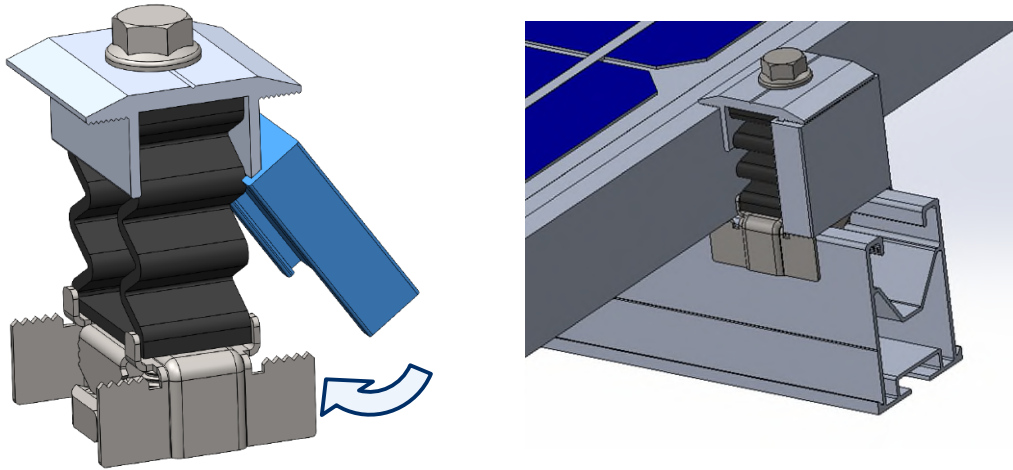

The chosen gauge size must be equal to the frame height of the solar panels to be installed.