

ST-GPX

SYSTEM DESCRIPTION

Triangular mounting system with **GP-XS** "guía perforada INDETRUT solar. Acero Atlantis C4-M, for the installation of solar panels



1. CHARACTERISTICS

Description:	Coplanar mounting system on GP-XS Atlantis C4-M perforated guide
System inclination:	Triangular mounting on pre-assembled triangles with adjustable inclination at 25°, 30° and 35°.
System orientation:	Facing SOUTH, EAST OR WEST depending on the roof orientation.
System materials:	Aluminium, stainless Steel and EPDM.
Warranty:	Until 10 years depending on environmental conditions (excluding environments exposed to hydrogen sulphide). The warranty is only valid if the complete ST-GPX system is used.
Compatible solar panels:	
Solar panels type:	Solar panels with frame height between 30mm and 40mm.
Solar panels orientation:	Mounting orientation of portrait (vertical)
Solar panel size	Panel length less than 1150 mm
Application area:	
Application area:	Flat and low-slope roofs.
Roof slope:	Up to 240 km/h. The structure and fixing must be calculated according to local and roof conditions.
Wind load:	Up to 2 kN/m ² . The structure and fixing must be calculated according to local and roof conditions.

2. COMPONENTS

Quick pre-assembled clamp		Simple clamp		INDEXTRUT quick nut		Gauge for solar frame		INDEXTRUT perforated guide		Connector for GP-XS guide		Pre-assembled and adjustable triangle INDEXTRUT	
	KFR-SC		PGS-A		TU-RXA2		GM-A		GP-XS		EMP-XS		TRP-XS

2.1 Components: Clamps and gauges for mounting solar panels

Lateral position clamp		Lateral position clamp	
Option 1: Quick clamp	Option 2: Simple clamp	Option 1: Quick clamp	Option 2: Simple clamp





















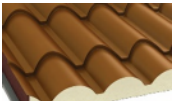











2.2 Components: Profiles, joints and guides for supporting structures

Longitudinal connection of profiles	Profile connection to the adjustable triangle

2.3 Components: mounting connectors for fixing accessories

Lower connection	
Fixing with adjustable roof hook for curved roof tile	Fixing with double threaded stud

3. TYPES OF FIXINGS

	ROOF	SUB-STRUCTURE	FIXING ACCESORIES				
TYPE 1	 <p>TILE</p>	 <p>CONCRETE</p>	 <p>GP-XS INDETRUT perforated guide</p>	 <p>PMO Plate for double threaded screw</p>	 <p>KFS-RV Threaded rod for chemical anchor installation.</p>	 <p>Chemical anchor</p>	 <p>MO-TM Wire Mesh Sleeves</p>
		 <p>HOLLOW CONCRETE</p>					 <p>MO-TL Long cut-out sieve for fixing on tile roof + scraper</p>
		 <p>HOLLOW BRICK</p>					
TYPE 2	 <p>TILE</p>	 <p>WOOD</p>	 <p>GP-XS INDETRUT perforated guide</p>	 <p>PMO Plate for double threaded screw</p>	 <p>KFS-RV Threaded rod for chemical anchor installation.</p>		
TYPE 3	 <p>TILE</p>	 <p>WOOD</p>	 <p>GP-XS INDETRUT perforated guide</p>	 <p>GS-TC Adjustable roof hook for curved roof tile</p>	 <p>GS-TP Roof hook for flat roof tile.</p>	 <p>DIN-571 A2 Long cut-out sieve for fixing on tile roof + scraper</p>	
		 <p>CONCRETE</p>		 <p>GS-TU Adjustable roof hook for universal roof tile</p>	 <p>GS-PI Roof hook for slate roofing tile</p>	 <p>TP A2 Countersunk head chipboard screw</p>	 <p>TN4S 4-way expansion plug</p>
		 <p>HOLLOW CONCRETE</p>		 <p>EQ-A2 Stud bolt for chemical anchor.</p>	 <p>HE + ARVUL Screw with vulcanized EPDM-steel washer.</p>	 <p>CHEMICAL ANCHOR</p>	
		 <p>HOLLOW BRICK</p>					 <p>MO-TN Plastic Mesh Sleeve</p>

4. EXAMPLES OF APPLICATION

Example 1: Curved tile roof with masonry substructure / fixing with roof hook GS-TC

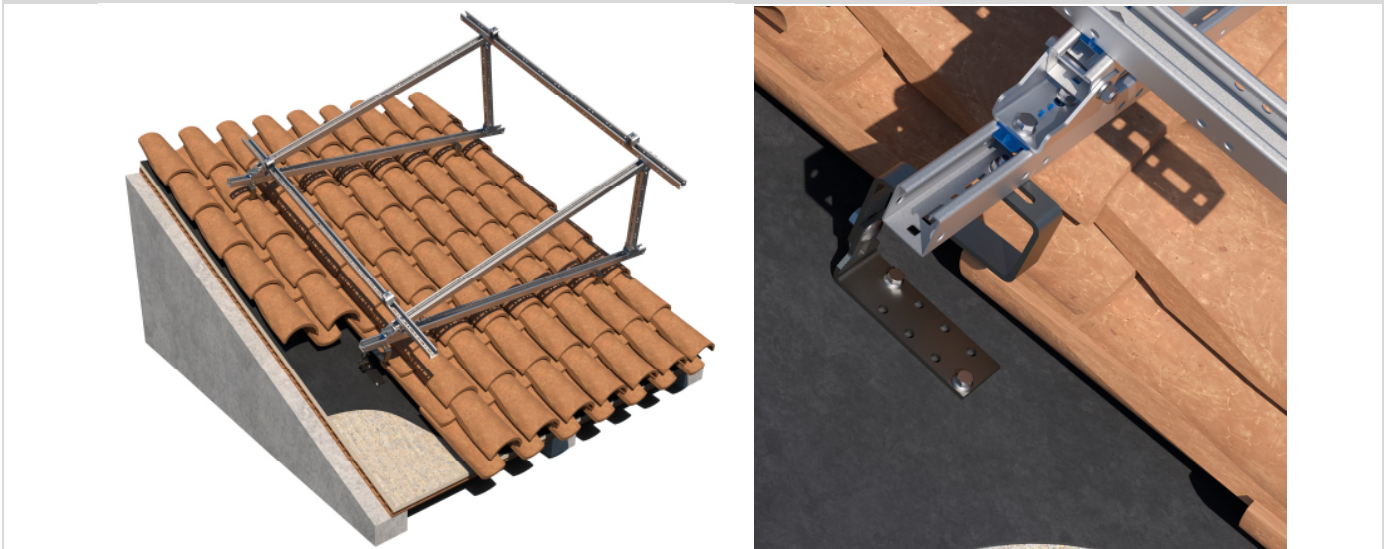

Example 2: Curved tile roof with wooden substructure / fixing with double threaded bolt KFS-MA



5. INSTALLATION MANUAL

ST-GPX

Triangular mounting system with GP-XS
“INDEXTRUT solar perforated guide.
Atlantis C4-M steel” fixing on roof tiles



Read these installation instructions before starting installation and familiarise yourself with the system components. Installation must only be carried out by qualified and experienced personnel.

Installation guidelines:

- Ensure that the roof construction is suitable for the introduction of forces at the fixing points and their subsequent transmission. The building must be able to safely receive the additional loads.
- A structural calculation must be carried out based on the local conditions at the installation site.
- The planning of the layout of the fixing points must be adapted to the requirements of the system and the roof.
- To compensate for thermal expansion, include a spacing every 12m when planning the PV system.
- The solar modules must be installed according to the manufacturer's instructions.
- Follow your local building regulations.
- Make sure to work in accordance with the health and safety regulations in force in your region, during installation and during roof work.
- Do not use the system or fixings as stairs.

INSTALLATION PROCESS

STEP 1.- Consult installation drawing

Consult the installation drawing on the roof, where the distribution of the modules is defined as well as the structures that support them and their fixing points.

A. Plan view of ST-GPX system with vertical module orientation (portrait type)

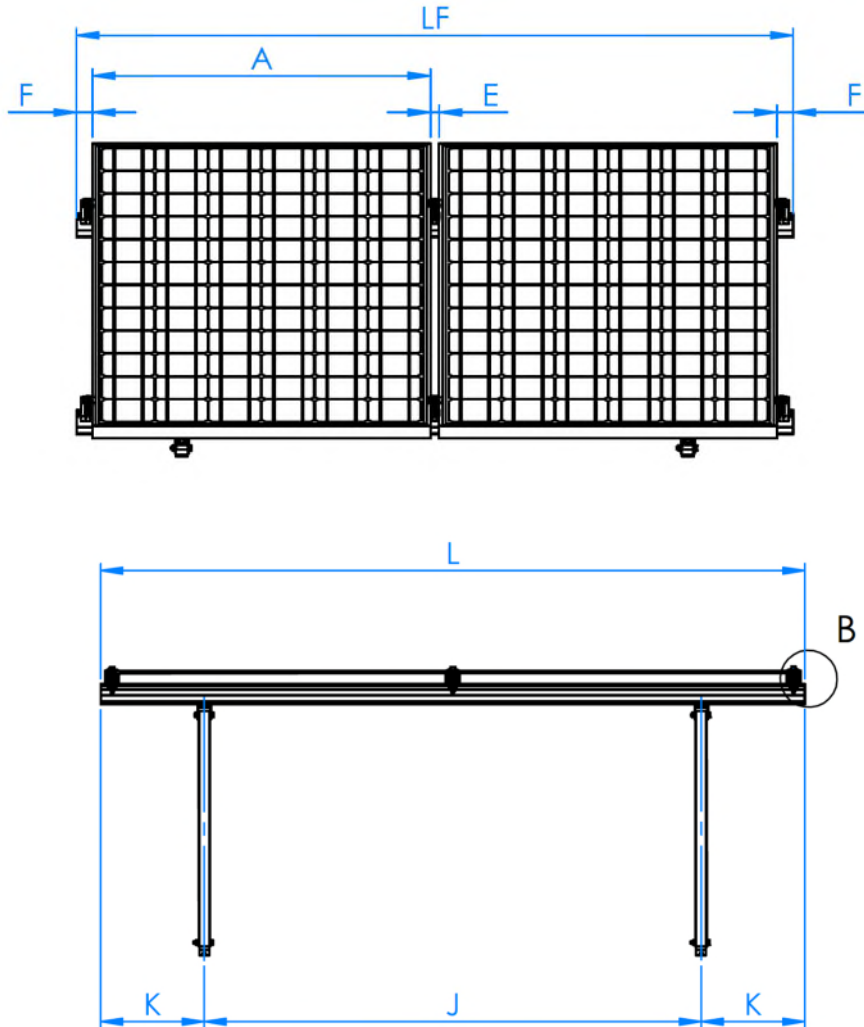

A (mm)	E (mm)	F (mm)	J (mm)	K (mm)	LF
≤ 1150	26	≥ 35	1400 ÷ 1600	(LF-J) / 2	(n*B) + ((n-1)*E) + (2*F)

n: number of modules in the row.

B. ST-GPX system profile view

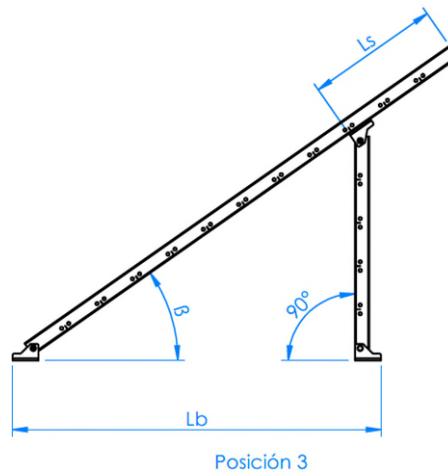
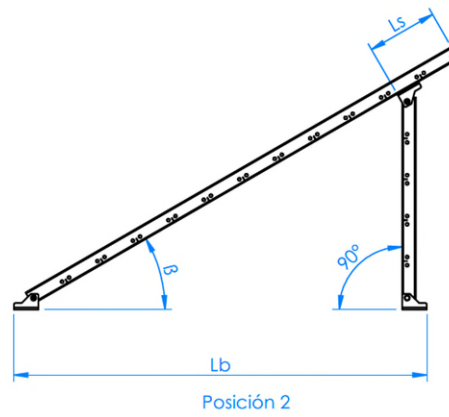
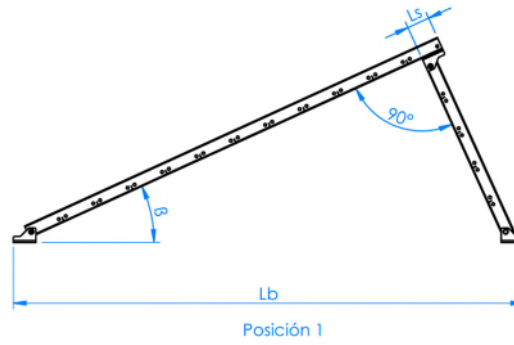

Position 1			Position 2			Position 3		
β (°C)	Ls (mm)	Lb (mm)	β (°C)	Ls (mm)	Lb (mm)	β (°C)	Ls (mm)	Lb (mm)
25	18	1696	30	118	1260	35	293	1052

The type of fixing system and the location of its installation points shall be adapted to the needs of the supporting structures and at the same time to the needs of the roofs where they must be installed.

STEP 2.- Perform layout on the roof

Lay out on the roof the fixing points of each structure, checking the viability of the installation of each one depending on the chosen fixing system and the characteristics of the roof.

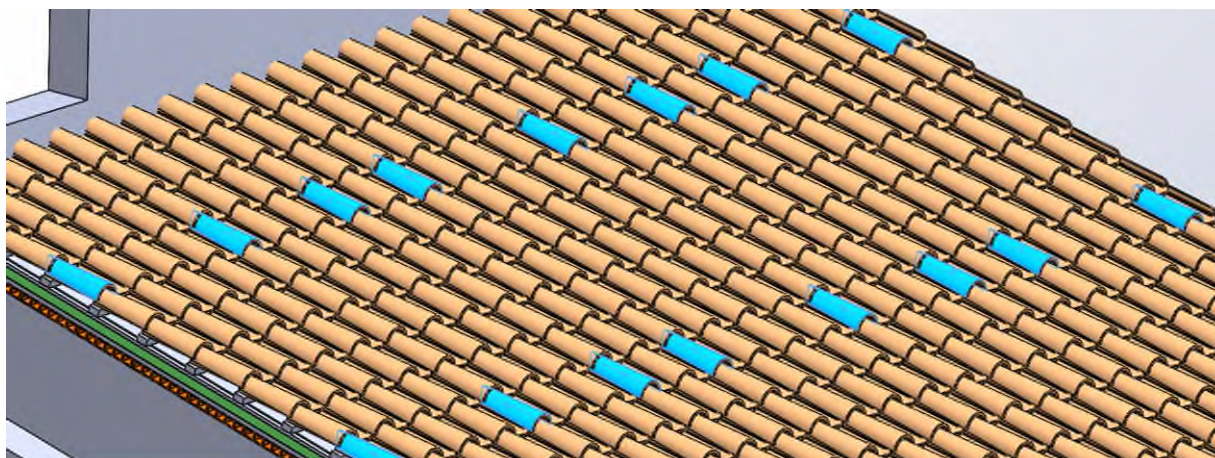

STEP 3.- Install the fixing

Install the fixings in accordance with the installation instructions contained in the respective data sheet.

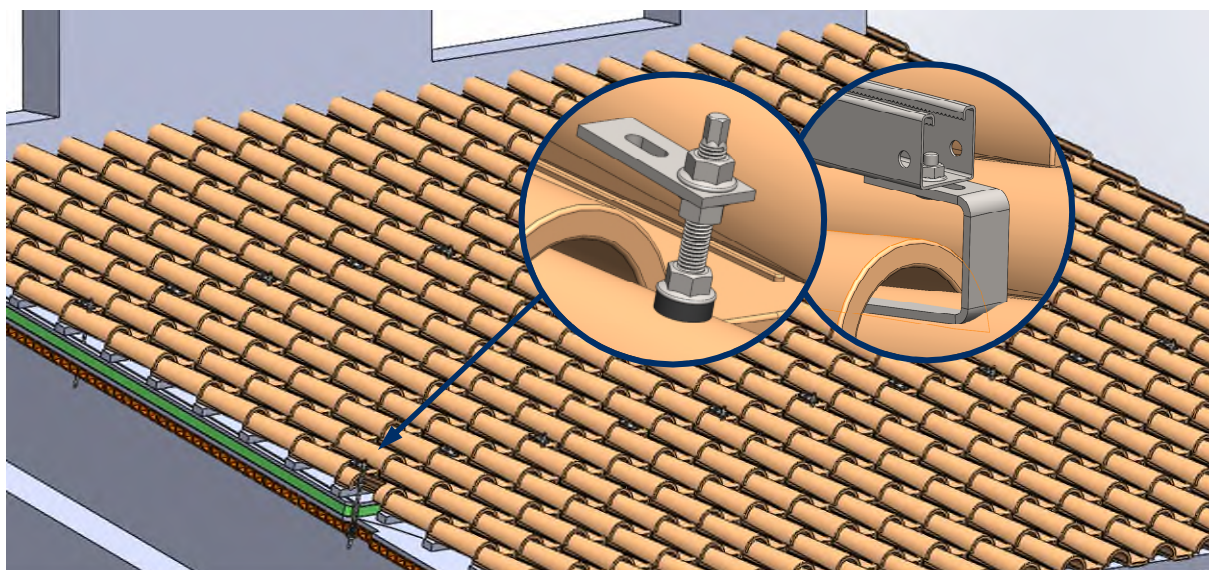

 <p>PMO Plate for double threaded screw</p> <p>Technical Data Sheet</p>	 <p>KFS-RV Threaded rod for chemical anchor installation.</p> <p>Technical Data Sheet</p>	 <p>KFS-MA Threaded rod for chemical anchor installation.</p> <p>Technical Data Sheet</p>	 <p>GS-TC Adjustable roof hook for curved roof tile</p> <p>Technical Data Sheet</p>	 <p>GS-TU Universal roof hook for roof tile</p> <p>Technical Data Sheet</p>	 <p>GS-TP Roof hook for flat roof tile.</p> <p>Technical Data Sheet</p>	 <p>GS-PI Roof hook for slate roofing tile</p> <p>Technical Data Sheet</p>
---	---	---	---	--	---	--

STEP 4.- Installation of the guides on the fixings

- a. **Option 1.** Fasten the GP-XS guide to the PMO plate using DIN 603 screws (M8x20) and DIN 6923 M8 nuts. Tighten to a maximum torque of 15 Nm using a SW-13 hexagon spanner. For further information, please refer to the SC-GPX assembly manual.

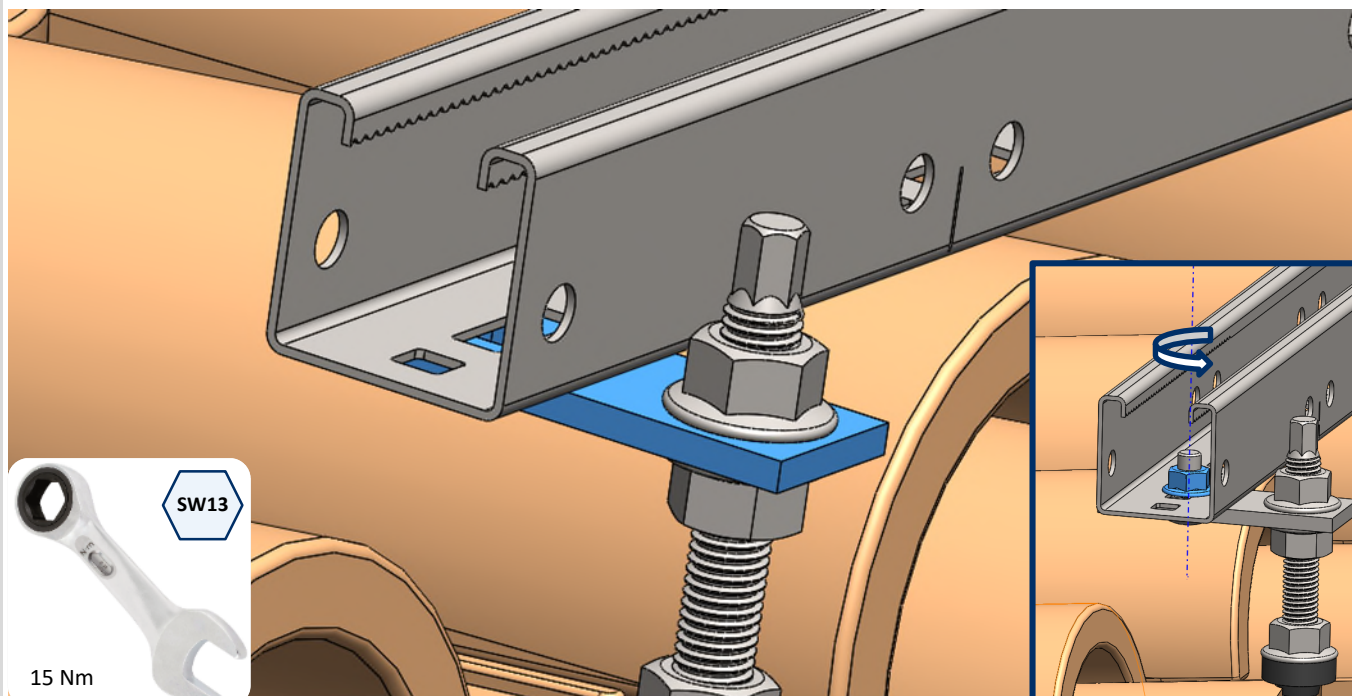

- b. **Option 2.** Fasten the GP-XS rail to the GS-TC busbar using DIN 603 bolts (M8x20) and DIN 6923 M8 nuts. Tighten to a maximum torque of 15 Nm using a SW-13 hexagon spanner.

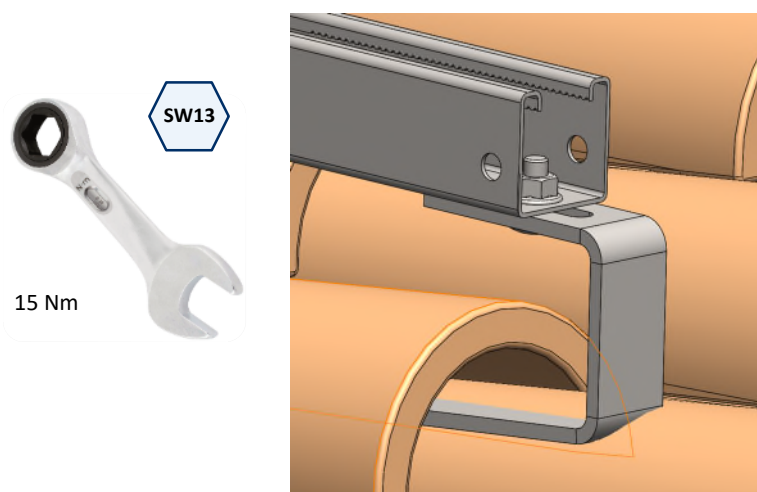

* In the following steps, the installation is explained independently of the selected fixing to the deck. will therefore only be shown with an example of fixing.

STEP 5.- Installation of the profiles on the rails

Fasten the pre-assembled TRP-XS triangles to the GP-XS profile using DIN 6921 screws (M8x20) and TU-RX A2 nuts. Tighten to a maximum torque of 15 Nm using a SW-13 hexagon spanner.

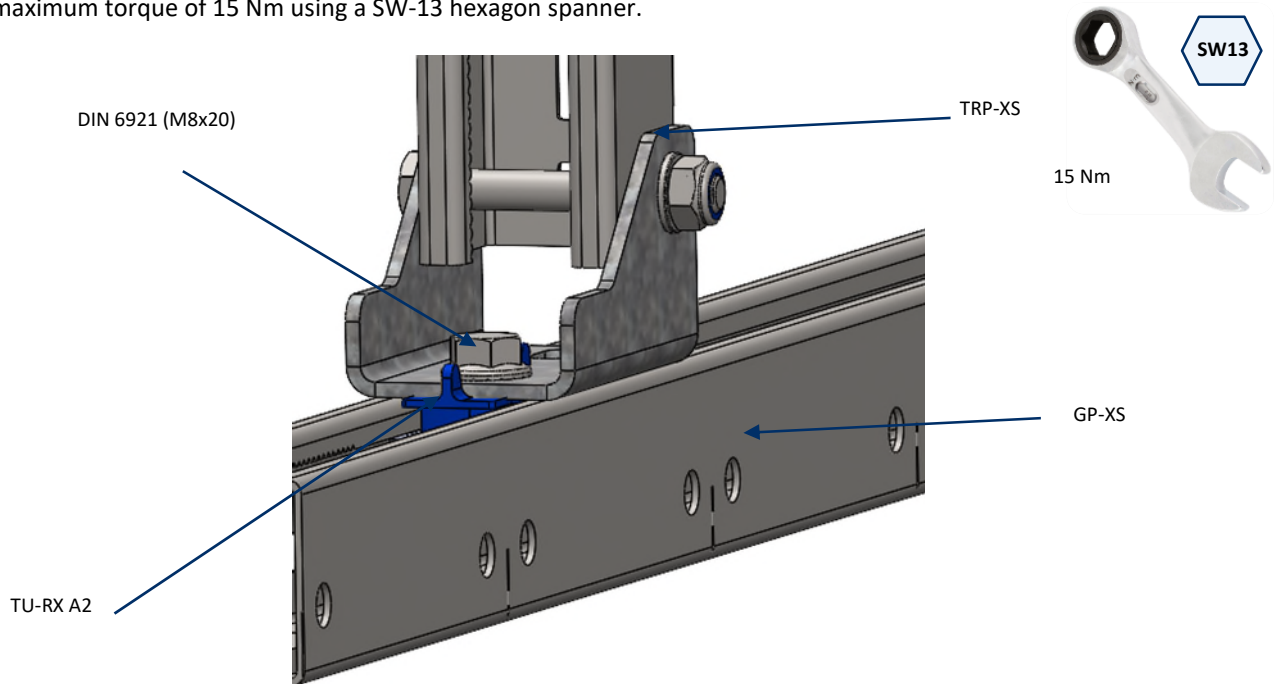

STEP 5.- Installation of the profiles on the triangles

- C. Position the GP-XS guides in the correct position for the installation of the panels.

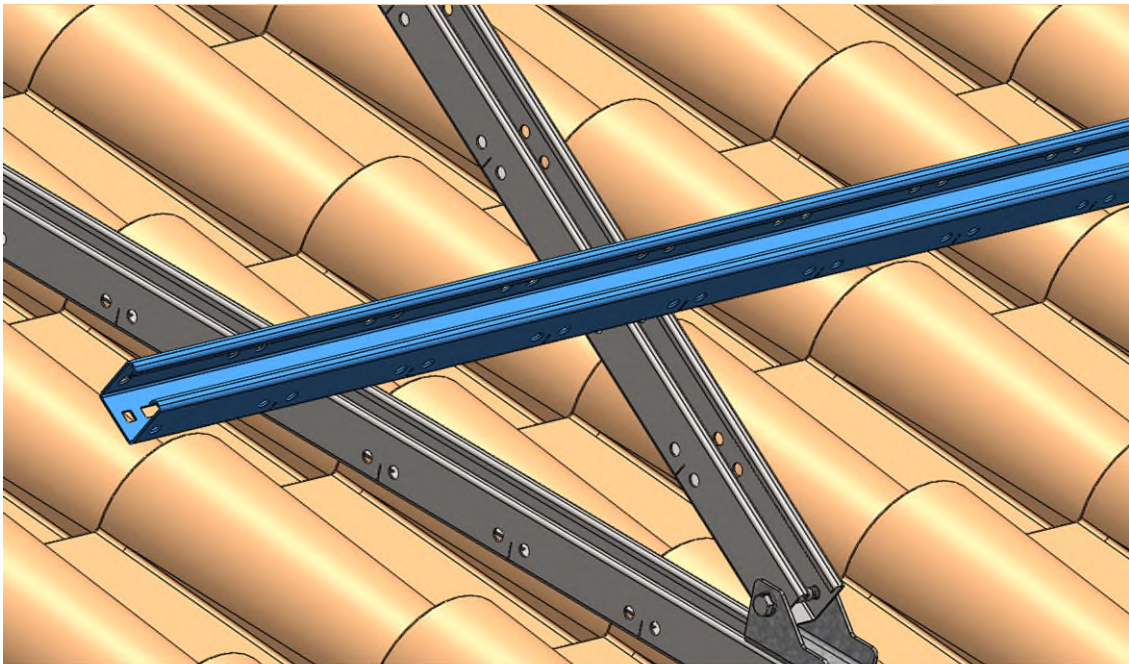

- D. Fix the position by using a DIN 6921 M8x20 bolt and TU-RX A2 nut. Tighten to a maximum torque of 15 Nm using a SW-13 hexagon spanner.

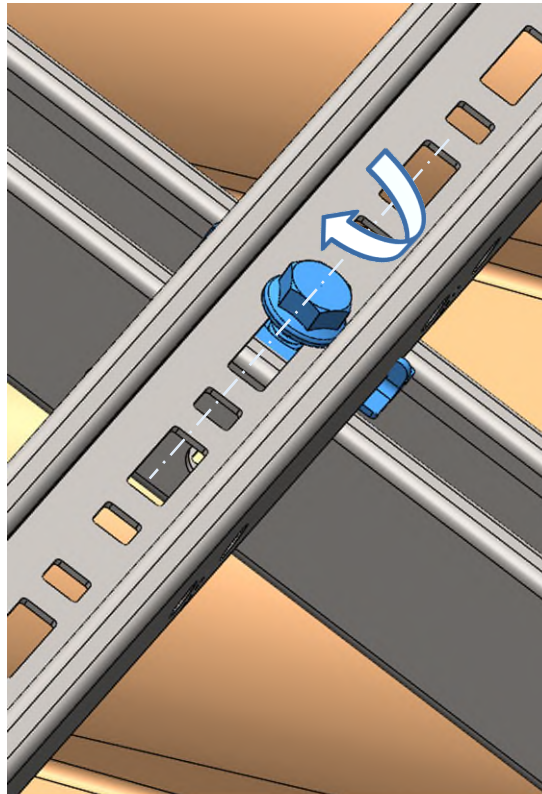

STEP 7.- Longitudinal connection between guides

- E. Assemble the EMP-XS joint by inserting half of the length into one of the two GP-XS guides.

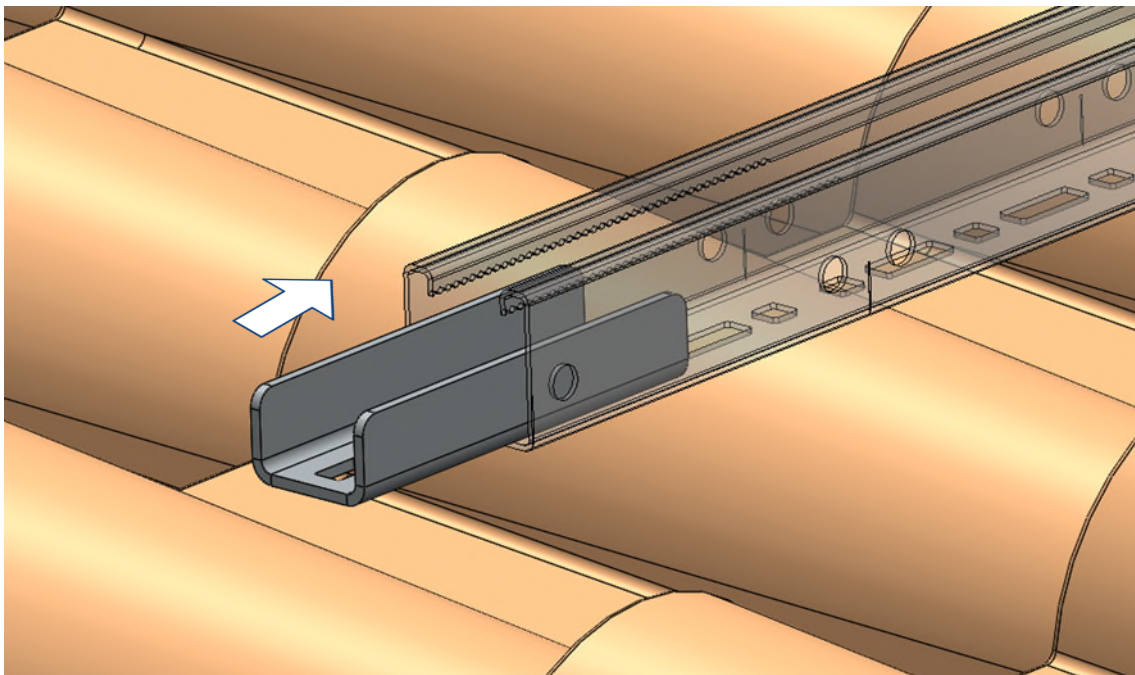

- F. Fix the EMP-XS joint to the first GP-XS guide by installing 2 screws DIN 603 (M8x20) and nuts DIN 6923 M8, at a distance between 50 and 70mm from the end of the guide. Use a SW-13 hexagon spanner to tighten to a maximum torque of 15 Nm.

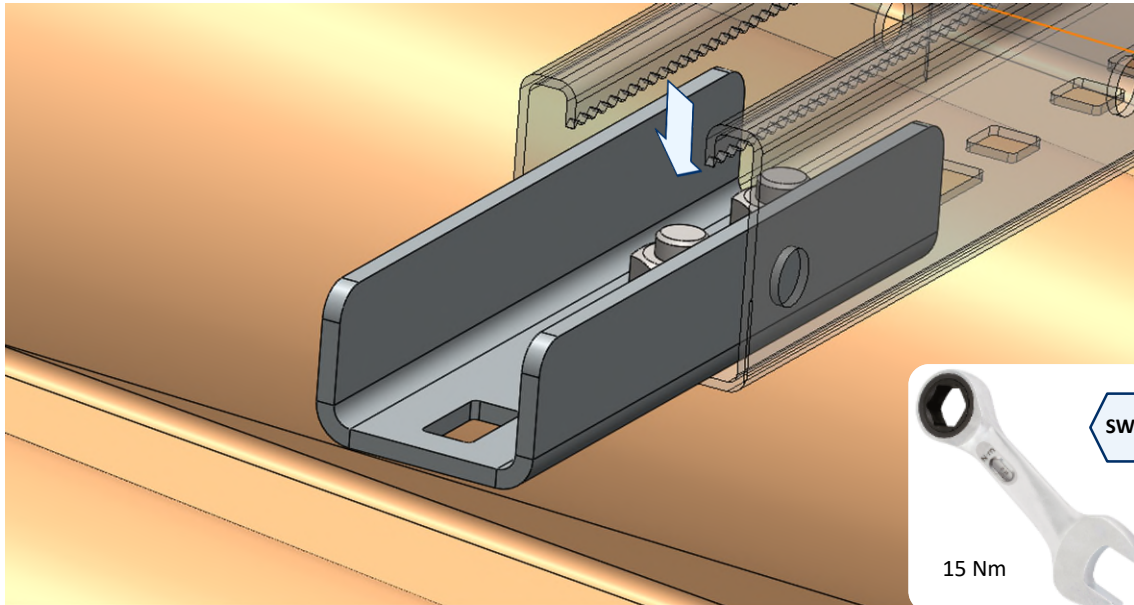

- G. Insert the free end of the EMP-XS connector into the second GP-XS guide.

- a. **Option 1**, if a rigid connection is required: Insert the protruding part of the EMP-XS connection into the second guide GP-XS until it butts against the first guide, and then fix the connection to this second guide by installing 2 DIN 603 screws (M8x20) and DIN 6923 M8 nuts, as previously carried out on the first guide.

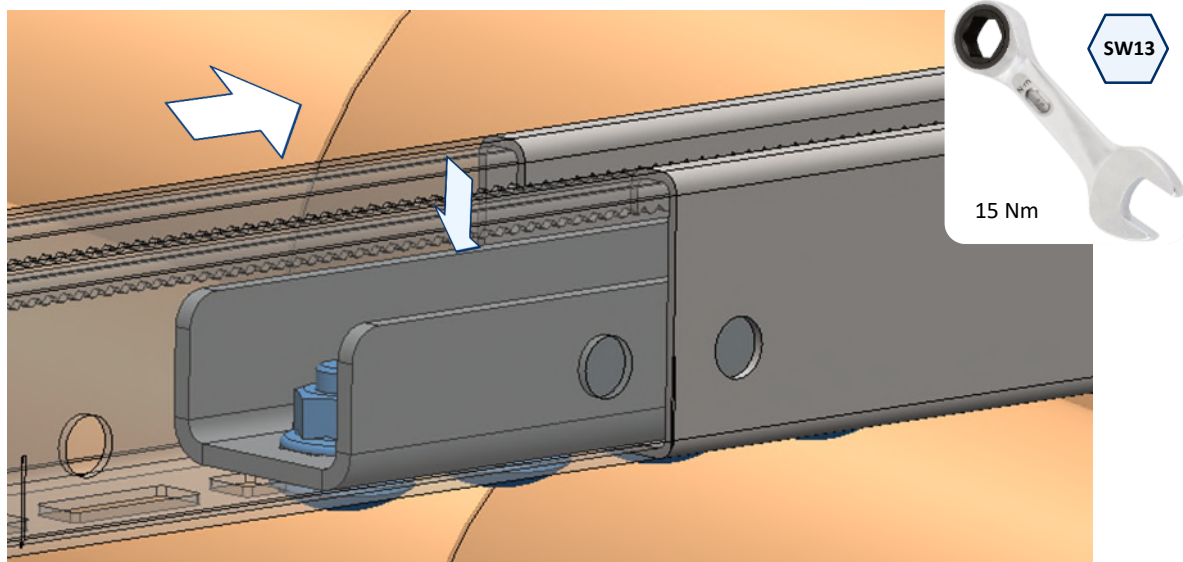

- b. **Option 2**, if a connection acting as an expansion joint is required: Insert the protruding part of the connection EMP-XS into the second guide GP-XS leaving a gap between the ends of both guides between 4 and 6 mm, in this case the screws are not installed to allow longitudinal displacements between the two guides.

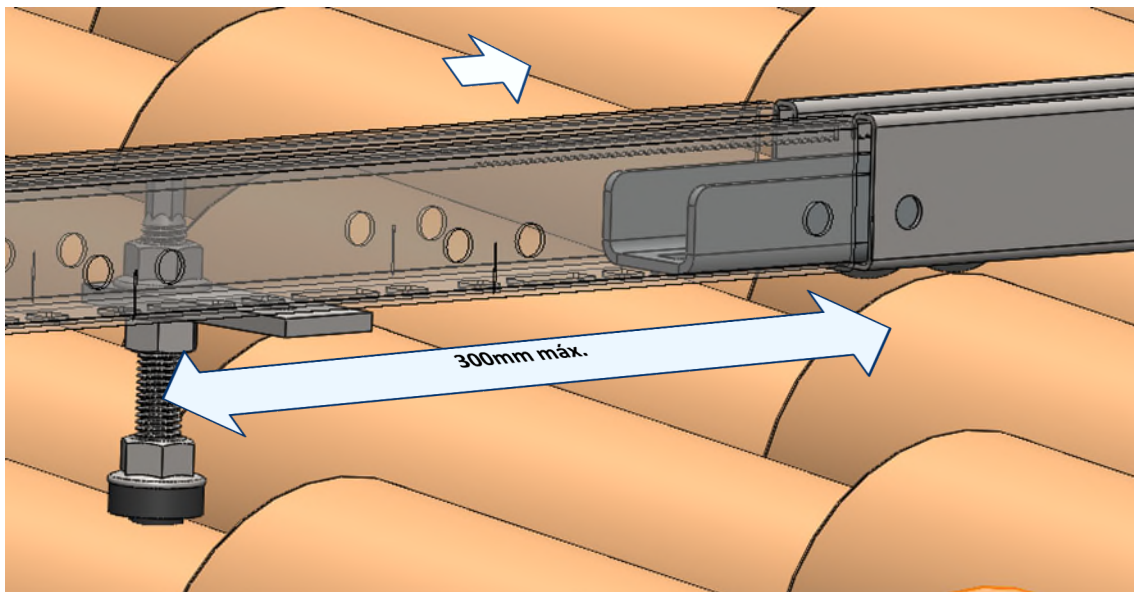

Is recommended for this type of connection a maximum distance to the nearest fixing point of 300 mm

PASO 8.- Pre-installation of clamps on the guides

To mount the clamp on the guides, the following steps are necessary:

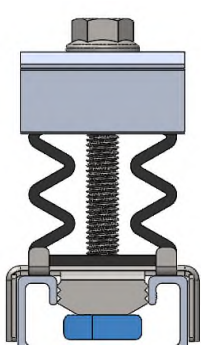

1. Place the clamp in the guide with the lower nut parallel to the guide.

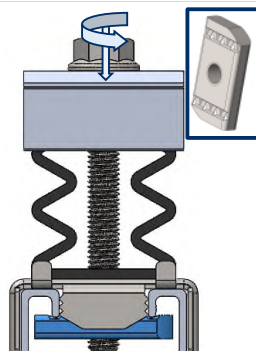

2. To fix the clamp to the guide, the lower nut must be turned perpendicular to the guide by means of the screw, the screw head is pressed down and turned. The nut has a serrated rail to secure the fixing.

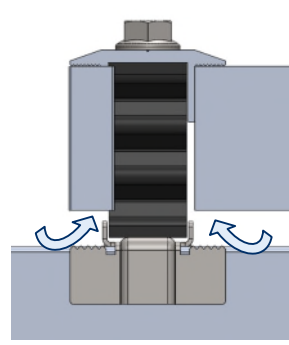

3. Insert the corresponding elements, two panels in the case of an intermediate clamp, or a panel and a gauge in the case of an end clamp.

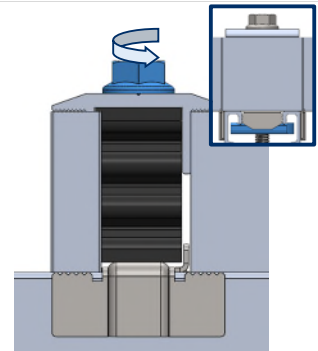

4. To fix the inserted elements it is necessary to turn the screw until they meet the guide. Check that the lower nut remains perpendicular to the guide.

Type of clamp depending on its position:

A. Intermediate clamp

- The intermediate clamp is used when passing from one module to another within the same row, fixing both panels to the structure. This assembly is carried out by means of the screw included in the clamp. A tightening torque of 14 Nm must be applied.

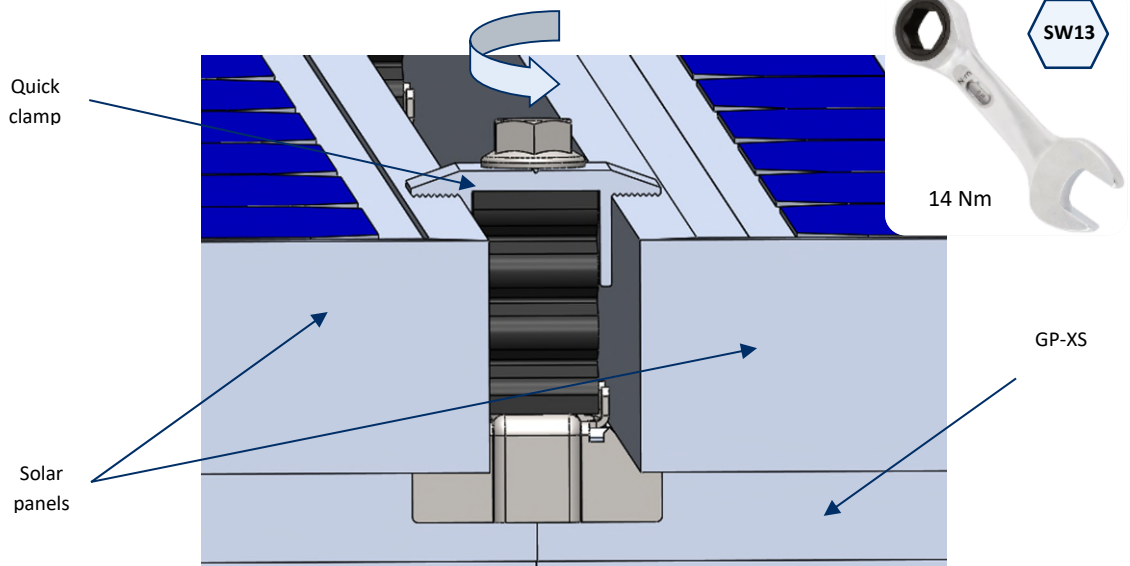

B. Lateral clamp

- Prepare 4 KFRSC3050 quick fixing clamps to be mounted at the ends of each row of panels. Each of these clamps is fitted with a GM-A gauge, mounted as shown in the figure:

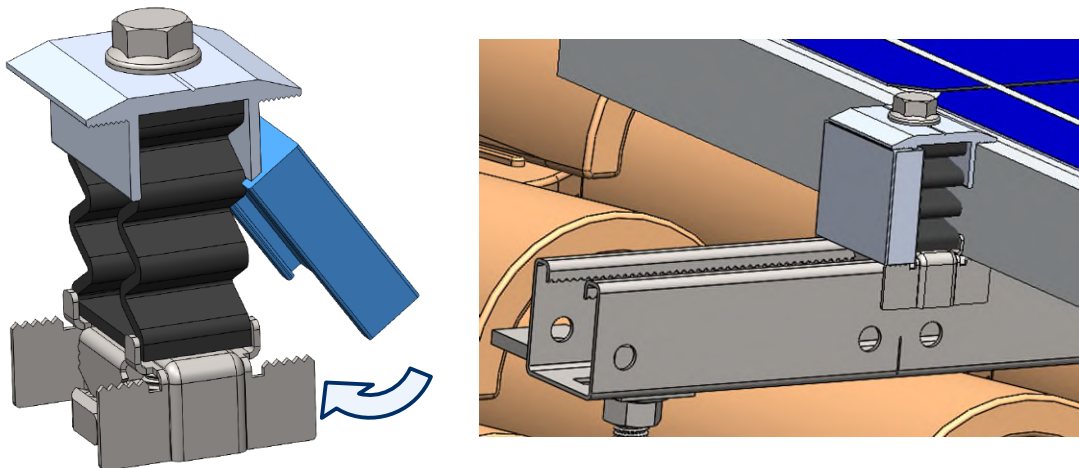

The chosen gauge size must be equal to the frame height of the solar panels to be installed.